

POS CENTRAL

Upgrade Your Business with Reliable POS Hardware & High-Performance Printing Solutions



Industrial Label Printer

Top Industrial Label Printing Machines & Thermal Printers for Every Business Need

From manufacturing floors to logistics hubs, [industrial label printer](#) delivers the precision, speed, and durability your operations demand. This presentation explores leading printer types, standout models, and the key features that help businesses scale efficiently.

RELIABLE

HIGH-PERFORMANCE

SCALABLE

INTRODUCTION

Industrial label printers are specifically engineered to handle high-volume, continuous printing tasks in demanding environments where standard printers often fail to perform efficiently. Built with rugged components, reinforced metal housings, and industrial-grade mechanisms, these machines deliver consistent and reliable performance across long operational hours. They are designed to withstand harsh conditions such as heat, dust, and vibrations, ensuring uninterrupted workflow. This makes them an ideal choice for industries that require durability, precision, and efficiency shift after shift without compromising output quality.

High Efficiency

Maximizes throughput with fast, uninterrupted print cycles

Precision Output

Sharp, accurate labels every time — no manual rework

Lasting Durability

Metal construction built to withstand harsh conditions

Industrial Thermal Printing: Two Core Technologies

THERMAL TRANSFER

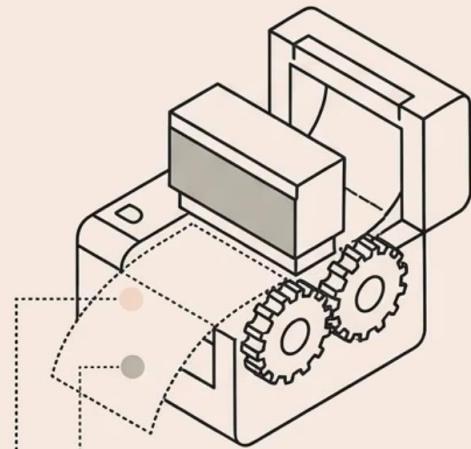

USES RIBBON



DURABLE
RESISTS ELEMENTS
LONG-TERM LABELING

DIRECT THERMAL

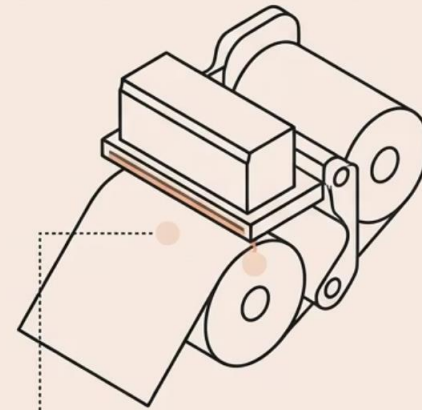

NO RIBBON

COST-EFFECTIVE

SHORT-TERM
LABELING

Choosing the Right Technology

The decision comes down to **label lifespan and application**. Thermal transfer is the gold standard for industrial environments where labels must endure heat, moisture, and chemical exposure. Direct thermal excels in high-speed, cost-conscious operations where labels have a shorter useful life.



Most industrial operations benefit from thermal transfer for permanent labeling and direct thermal for logistics and shipping workflows.

Key Features That Set Industrial Printers Apart



203–600 DPI Resolution

Crystal-clear barcodes and text, even at small label sizes



High-Speed Printing

Handles large-scale print runs without slowdowns or jams



Rugged Metal Build

Industrial-grade housing withstands dust, vibration, and impact



Multiple Connectivity

USB, LAN, and Serial interfaces for seamless system integration



Large Media Capacity

Oversized label rolls minimize downtime and operator intervention



User-Friendly Interface

Intuitive LCD displays simplify setup, adjustments, and diagnostics

Types of Industrial Label Printers



Thermal Transfer

Ribbon-based technology producing durable, chemical-resistant labels for long-term industrial use



Direct Thermal

No ribbon required — fast and cost-effective for short-term shipping and distribution labels

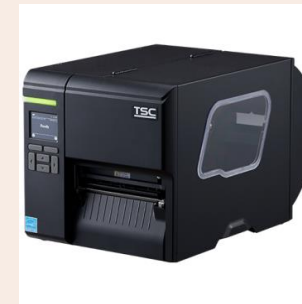

Barcode Label Printers

Purpose-built for tracking and inventory management across warehousing and retail environments



Heavy-Duty Industrial

Engineered for continuous, high-volume output in the most demanding production environments

Featured Product Lineup – TSC Series

TSC industrial printers deliver proven performance across mid-volume to heavy-duty applications. Each model is engineered for reliability, flexibility, and long-term value.

Model	Technology	Best For	Resolution
TSC ML241P	Direct Thermal	Mid-volume applications	203 DPI
TSC MB241T	Thermal Transfer & Direct Thermal	Versatile, mixed-use environments	203 DPI
TSC MH241T	Thermal Transfer & Direct Thermal	High-speed heavy-duty operations	203 DPI
TSC TTP-384MT	Thermal Transfer & Direct Thermal	Wide-format, high-resolution output	300 DPI

Expanded Solutions for Every Operation



Wide-Format Printers

Ideal for large-size labels, packaging inserts, and pallet-level identification where standard widths fall short



High-Speed Bulk Printers

Designed for peak-throughput environments – handles thousands of labels per shift without interruption



Compact Industrial Printers

Space-saving footprints that fit seamlessly on production lines or packing stations without sacrificing output quality



Advanced Barcode Printers

Supports complex barcode symbologies and QR codes for real-time inventory tracking and supply chain integration

TSC ML241P 203 DPI Industrial Label Printer



Where Industrial Printers Make an Impact

Manufacturing

Product labeling, part identification, and packaging compliance across assembly lines

Warehousing & Logistics

Shipping labels, pallet tags, and real-time tracking across distribution networks

Retail

Barcode generation, price labeling, and shelf-edge tags that accelerate checkout and stocking

Healthcare

Compliance labeling, specimen tracking, and patient identification with zero tolerance for error

Why Businesses Invest in Industrial Printers

The ROI is clear: [industrial label printers](#) reduce downtime, eliminate costly manual errors, and deliver consistent output that keeps operations running at full capacity — even in the harshest environments.

→ Higher Productivity

High-speed print engines handle bulk jobs that would overwhelm standard printers

→ Fewer Errors

Precise output reduces mislabeling and costly inventory discrepancies

→ Lower Long-Term Costs

Durable construction means fewer replacements and less unplanned downtime

→ Harsh-Environment Ready

Performs reliably in extreme temperatures, humidity, and high-dust conditions

Ready to Upgrade Your Labeling Operations?

The right industrial label printer is a strategic investment — one that pays dividends in speed, accuracy, and reliability for years to come. Whether you're scaling production, modernizing a warehouse, or ensuring compliance, there's a solution built for your needs.

Explore the Full Range

Browse industrial thermal printers across all formats, speeds, and resolutions

Match Your Application

From compact barcode printers to wide-format heavy-duty models

Optimize & Scale

Upgrade your workflow, reduce costs, and stay ahead in a competitive market



For more information Visit us :

- **Address** : Unit no. 703, A-10, Sector 68, Noida, UP 201301 India
- **Website** : <https://www.poscentral.in/>
- **E-Mail ID** : sales@poscentral.in
- For any query call us @ 9205081551

**THANK
YOU**