

# 49 GARAGE

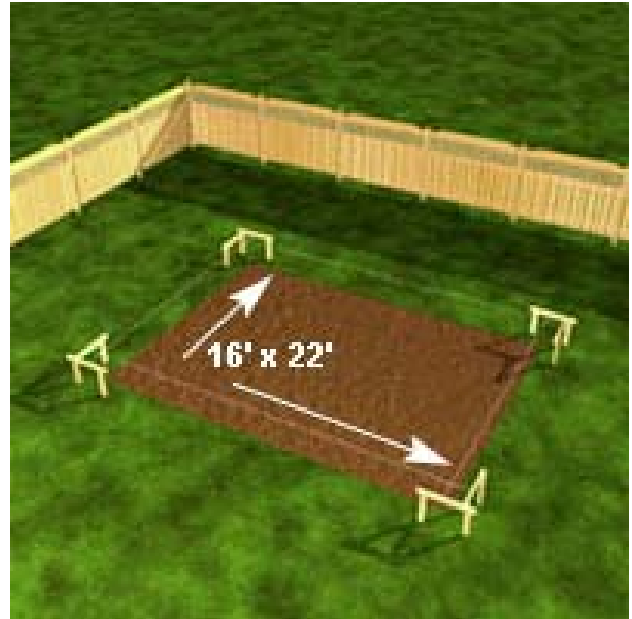

## 1. Build the foundation and floor

1.1 Carefully mark the location of the garage on your lot. Hire a surveyor to precisely locate the site for the garage and define the excavation area.



1.2 Have a contractor excavate the designated site to the required depth. He will properly dispose of the dirt excavated.

1.3 In order to build the foundation, we recommend you contract out this job. The foundation specialist will start with the footing, the concrete walls and backfilling before making the foundation slab. Make sure that anchor bolts are encased, centered every 4 feet (1.2 m).

## 2. Build the walls

### 2.1 Outside walls

Start the outside walls building them flat on the ground, using lumber with less than 19% moisture content. Wall studs should be centered every 16 in. (406 mm) and made of 2 x 4 in. (50 x 100 mm) timber. Strengthen the base of the walls with a 4 in. (100 mm) bottom plate in which you will drill holes every 4 ft. (1.2 m) for the anchor bolts.

#### 2.1.1

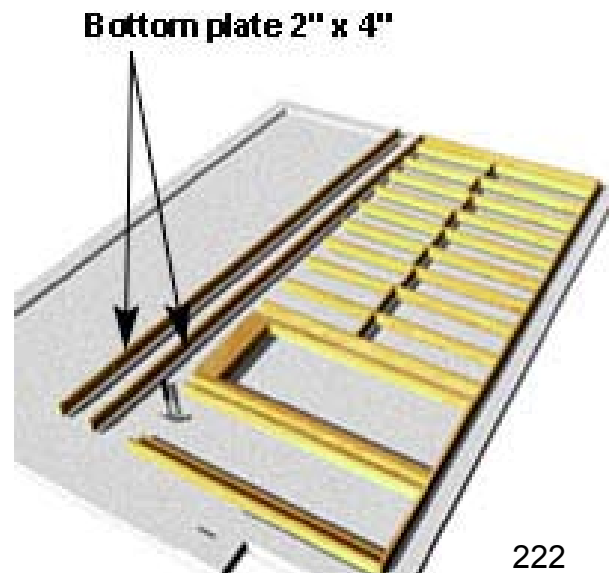

Separate the top and bottom plate slightly more than a stud's length apart with the bottom plate positioned nearest the wall's final location. Center the studs every 16 in. (406 mm). Attach pre-nailed double 2 x 4 in. (50 x 100 mm) top plates above the studs.

**2.1.2** A secondary stud made of two planks solidly nailed together will delineate the sides of the door or window opening and support the coping.

**2.1.3** The lintel (window contour) load will be transmitted to the twin studs on each side of the opening. To install a lintel, nail a 2 x 10 in. (50 x 254 mm) each wall face. Fill the empty space between them with insulation material.

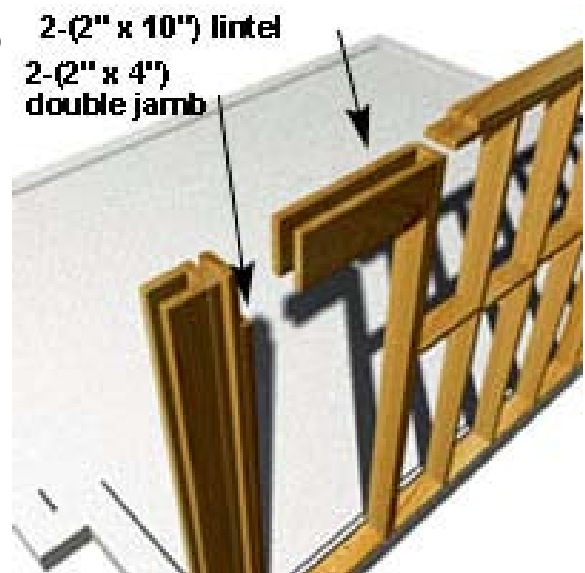

## **2.2 The garage door framing**

Build the two short sections on either side of the large opening using three 2 x 6 in. (50 x 152 mm) studs nailed together. The top part of the frame (called lintel or header), is made up of three 2 x 10 in. (50 x 254 mm) nailed together then nailed to the trimmer studs of the two side sections.

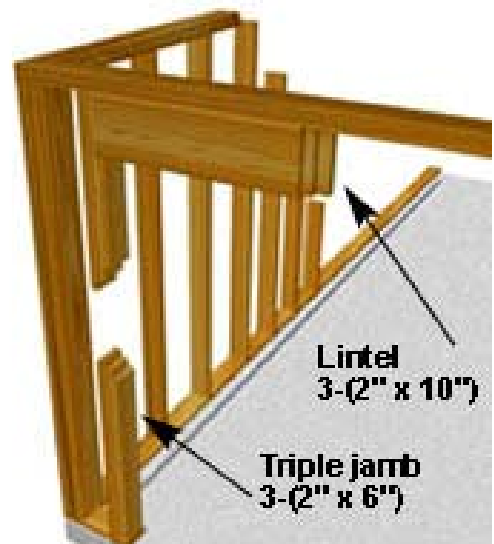

## **2.3 Sheathing and air barrier**

**2.3.1** The suggested sheathing material is 4 x 8 ft (1.2 x 2.4 m) tarred fiberboard panels. Use a thin plastic air barrier.

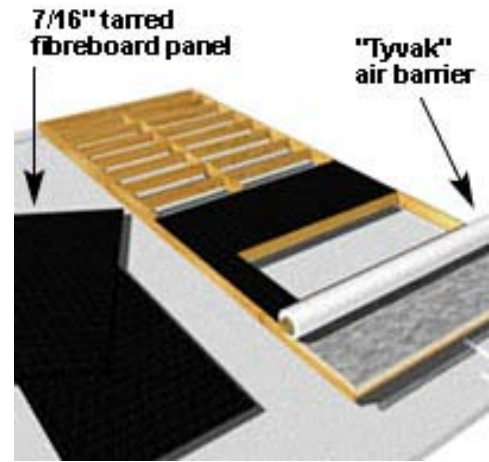

**2.3.2** First, apply the sheathing, positioning the panels on the wall (that is still flat on the ground) and nail to frame with dog nails. Apply the air barrier and nail or staple into place. Lastly, install fillers every 16 in. (406 mm).

**2.4** Before lifting the wall into place, make sure the bottom plate is well positioned. At this stage, make sure you have enough people to lift and hold the wall in position while bracing. Nail braces from the top of the wall into stakes driven into the ground outside the wall and nail the wall upright to hold it temporarily.



### 3. Build the roof

**3.1** With the walls up, you should close the roof as soon as possible to avoid rain or wind damage to the inside of your garage. Roof trusses are a pre-built series of structural members designed to carry the load of the roof to the outside walls. Trusses are built in special factories to the individual specifications for your garage plans.

**3.2** Trusses are designed to resist loads only when they are in a vertical position. That is why they should not be lifted flat or laid over the top of the outside walls. Gently lift the trusses mechanically or with a rope and pulley.



**3.3** Beginning at one end, measure and mark every 24 in. (610 mm) the location of the roof trusses on the top plate. Nail the trusses in place.

**3.4** With the trusses installed, nail a temporary brace to each one. You can now start putting up the edge boards. Apply roof sheathing. Plywood or particleboard roof sheathing is most commonly used, being rigid, durable, non-slip and easy to apply.



**3.5** Align panels perpendicular to the rafters and stagger the joints of each course. Panels should meet in the center of a truss or rafter. Leave a small gap between the panels for contraction of the material. According to the truss spacing, the horizontal edges of the panels should be attached every 24 in. (610 mm). To prevent sagging, use sheathing clips to attach the panels between the trusses.



#### **4. Install doors and windows**

Doors usually come with comprehensive installations, a pre-mung door is expensive and if not properly installed, will loose it,s energy efficiency and will not operate properly in the long run. It is recoomended to have your door indtalled by a professional. However, if you decide to do itself follow these instructions and get some help as they tend to be heavy.

#### **5. Install the asphalt shingles**

The next step is to install the asphalt shingles.

## **6. Install the outside siding**

It is now the very last step, the one that has to do with the outside siding.

The construction of a garage is a huge project. Once it is completed you'll be proud of it. You will find it very useful and not only to put your car away in Winter.