



## Entry Hall Table

*The dimensions of this entry hall table (approximately 51 inches long by 12-1/2 inches wide by 26-1/2 inches high) make it extremely versatile. I use it alongside a staircase, but it would also be perfect behind a sofa or love seat. Then you can call it a “sofa table.”*



### Materials List

- 1 piece laminated 1 x 4 pine, 48” x 20” (or 25 linear feet 1 x 4 pine)
- 33 linear feet 1 x 4 pine
- 11 linear feet 1 x 2 pine
- 11 linear feet decorative molding – at least 3-1/2” wide x 1” thick (top) and 3/4” thick (bottom)
- 9 linear feet 2 x 2 pine
- 11 linear feet very thin brass, 1-1/2” wide

### Hardware:

- Approx. 100 #6 x 1-1/4” flathead wood screws
- Approx. 150 #6 x 2” flathead wood screws
- Approx. 75 3d finishing nails

### Special Tools and Techniques

2 or 3 heavy-duty bar clamps (optional)

- levels
- miters

## ***Cutting List***

| <b>Code</b> | <b>Description</b>      | <b>Qty.</b> | <b>Material</b>           | <b>Dimensions</b> |
|-------------|-------------------------|-------------|---------------------------|-------------------|
| A           | Table Top               | 1           | Laminated pine            | 47-1/2" x 9"      |
| B           | Shelf                   | 1           | Laminated pine            | 47-1/2" x 9"      |
| C           | Leg                     | 8           | 1 x 4 pine                | 22-1/2" long      |
| D           | Short Leg Reinforcement | 4           | 2 x 2 pine                | 8-1/2" long       |
| E           | Long Leg Reinforcement  | 4           | 2 x 2 pine                | 16" long          |
| F           | Short Shelf Trim        | 2           | 1 x 4 pine                | 3-1/2" long       |
| G           | Long Shelf Trim         | 2           | 1 x 4 pine                | 42" long          |
| H           | Short Table Trim        | 2           | 1 x 4 pine                | 9" long           |
| I           | Long Table Trim         | 2           | 1 x 4 pine                | 49" long          |
| J           | Long Molding            | 2           | 3-1/2" decorative molding | 51" long          |
| K           | Short Molding           | 2           | 3-1/2" decorative molding | 12-1/2" long      |
| L           | Long Brass Support      | 2           | 1 x 2 pine                | 51" long          |
| M           | Short Brass Support     | 2           | 1 x 2 pine                | 12-1/2" long      |

## ***Making the Top and shelf***

The table top and the shelf are both constructed of laminated 1 x 4 pine boards. Most building supply stores sell sections of pine that have already been laminated. If you want to laminate the boards yourself, you need 25 linear feet of 1 x 4 pine and at least two heavy-duty bar clamps.

1. If you have purchased pine that is already laminated, simply cut two sections, each 47-1/2" x 9", making the table top (A) and the shelf section (B). Then skip to "Constructing the Legs," below.
2. If you want to do the laminating yourself, cut three lengths of 1 x 4 pine, each 48" long, for the table top (A). To ensure a solid bond in the lamination process, it is a good idea to rip a minuscule amount from each edge to be laminated before gluing the wood lengths together. Then spread glue on the edges, and place the lengths of wood side by side. Clamp them together securely, using at least two bar clamps, and leave them overnight.
3. Trim the completed table top (A) to 47-1/2" x 9".
4. Repeat the process described in Steps 2 and 3 to construct the laminated shelf section (B), which is also 47-1/2" x 9".

## Constructing the Legs

1. Cut eight leg pieces (C) from 1 x 4 pine, each 22-1/2" long. Then set your saw blade to cut 45 degrees off vertical, and bevel one 22-1/2"-long edge of each of the legs (C) as shown in *Figure 1*.

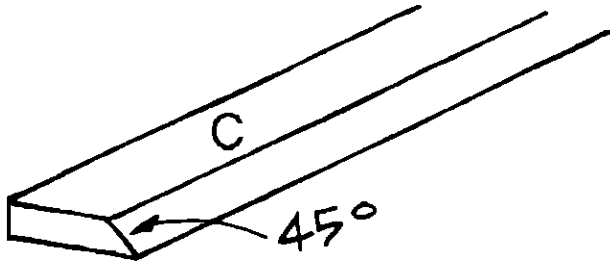

*Figure 1*

2. Cut four short leg reinforcements (D) from 2 x 2 pine, each 8-1/2" long.
3. After wiping both beveled edges with glue, place two leg pieces (C) together, joining the bevels. Then attach one short leg reinforcement (D) to the inside of the beveled joint. Position the leg reinforcement (D) flush with the ends of the legs (C), as shown in *Figure 2*. Use glue and 2"-long screws for this assembly. Drive three screws into each of the two leg pieces (C).

4. Repeat Step 3 three more times to construct the remaining legs.

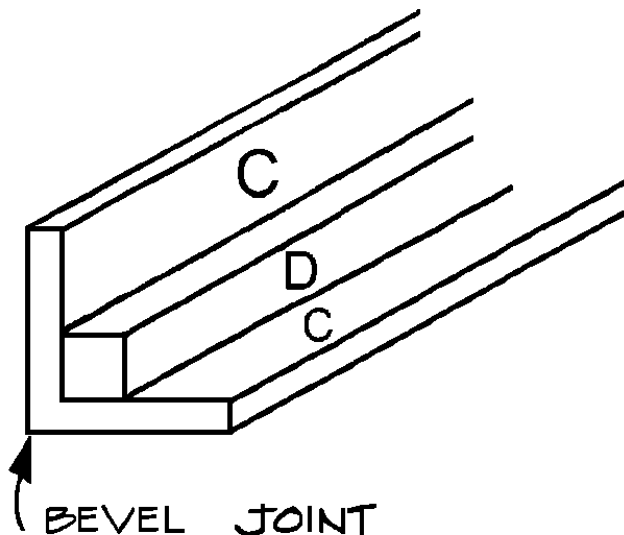

*Figure 2*

## Adding the Shelf

1. Stand the four leg assemblies upright on a level surface with the short leg reinforcements (D) facing each other. Place the laminated shelf section (B) in the center of the leg assemblies so that it is resting on the leg reinforcements (D), as shown in *Figure 3*.

This operation is one that may require the assistance of a willing helper because it is critical that all four leg assemblies remain level as you perform the next operation.

2. Apply glue on the surfaces to be joined, and screw through the laminated shelf (B) into the ends of the short leg reinforcements (D). Use two 2-inch screws at each corner of the laminated shelf (B).
3. Cut four long leg reinforcements (E) from 2 x 2 pine, each 16" long. Apply glue and use 2"-long screws to attach the long leg reinforcements (E) to the inside edges of the beveled legs (C) above the laminated shelf (B). Use eight screws for each corner, putting four screws into each leg. As illustrated in *Figure 3*, the long leg reinforcements (E) extend 2-3/4" above the leg assemblies.

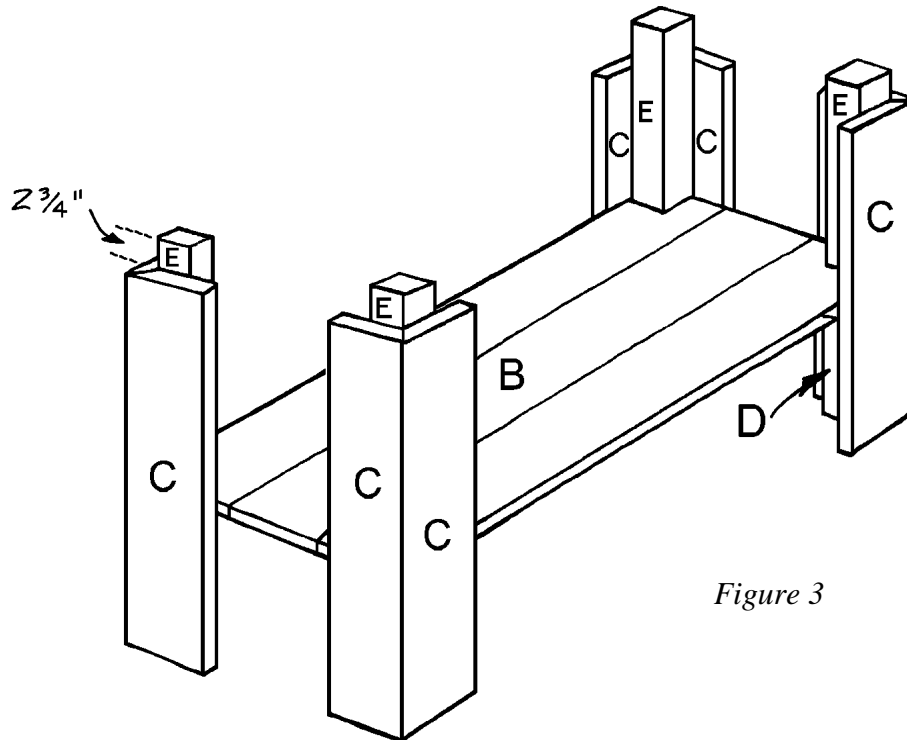

*Figure 3*

4. Cut two short shelf trim pieces (F) from 1 x 4 pine, each 3-1/2" long. Nail and glue them to the short sides of the laminated shelf (B), flush with the top of the shelf (B), as shown in *Figure 4*. Use about three 3-penny finishing nails on each short shelf trim piece (F).
5. Cut two long shelf trim pieces (G) from 1 x 4 pine, each 42" long. Nail and glue them to the long sides of the laminated shelf (B), flush with the top of the shelf (B). Space the nails about 6" apart.

### ***Constructing the Table Top***

1. First cut two short table trim pieces (H) from 1 x 4 pine, each 9" long. Then cut two long table trim pieces (I) for 1 x 4 pine, each 49" long.

- Carefully set the laminated table top (A) upside down on a level surface. Now place one short table trim piece (H) on edge at each end of the table top (A), as shown in *Figure 5*. Use glue and three 1-1/4"-long screws to attach each short table trim piece (H) to the table top (A).

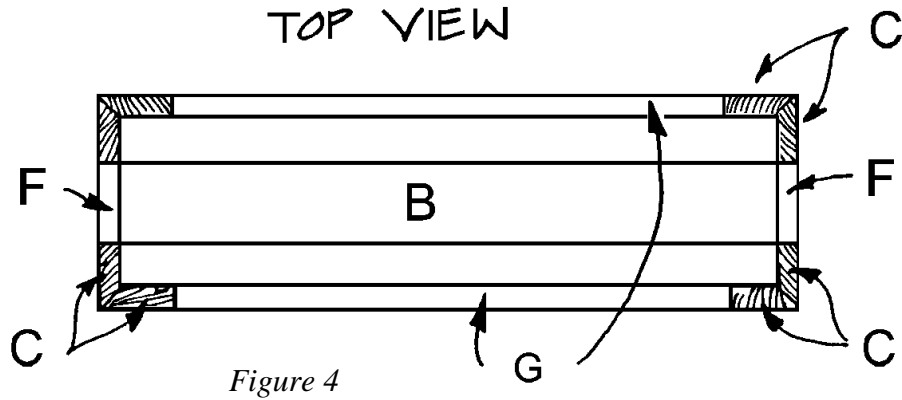

- The long trim pieces (I) extend over the ends of the short trim pieces (H). (See *Figure 5*.) Attach the long trim (I) to the table top (A) with glue and screws. Use 1-1/4"-long screws spaced about 6" apart.
- Set the completed table top onto the leg and shelf assembly. Make sure that the table trim pieces (H and I) rest on the legs (C) and that the table top (A) is supported by the long leg reinforcements (E).
- Glue and screw through the long leg reinforcements (E) into both the long and short trim pieces (H and I) to secure the table top. Place two 2"-long screws in each of the corners.

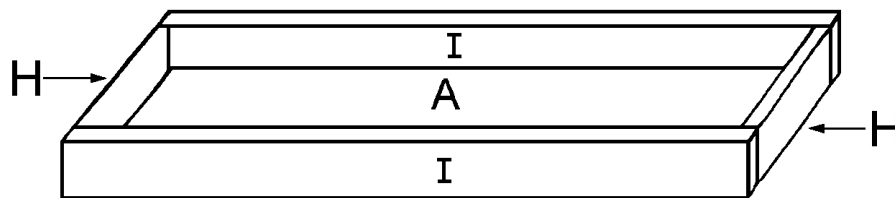

### **Adding the Trim**

The table structure is now complete. The remaining steps are to cover the table trim pieces (H and I) with decorative molding, attach support pieces for the brass, and attach the brass trim.

- From the 3-1/2"-wide decorative molding, cut two long molding pieces (J), each 51" long, and two short molding pieces (K), each 12-1/2" long.

2. With each piece standing on edge, carefully miter the ends of each of the long and short molding pieces (J and K) at a 45-degree angle. Attach the molding pieces (J and K) to fit perfectly over the table trim pieces (H and I). Use glue and 3-penny finishing nails, placing one nail every 6 inches. Countersink the nails.
3. From 1 x 2 pine, cut two long brass support pieces (L), each 51" long, and two short brass support pieces (M), each 12-1/2" long.
4. Stand each of the brass support pieces (L and M) on edge and miter both ends at a 45-degree angle. Attach the mitered lengths just under the molding pieces (J and K). Use glue and finishing nails, spacing the nails about 6" apart. Countersink the nails.

### ***Finishing the Table***

1. Carefully fill any imperfections and nail holes with wood filler. Then sand the entire table.
2. Stain the table the color of your choice, and let the project dry overnight.
3. Attach the thin brass to the 1 x 2 brass support pieces (L and M) with glue suitable for both metal and wood; several brands are readily available. Since I planned to place the back of the table against a wall, I clamped the brass trim (positioned the joint) at the center back of the table and worked my way around. If you want to display the table where all four sides will be visible, you may want to begin at a corner and work your way around. To hide the joint where you begin and end the brass, purchase brass corner pieces to cover all four corners.

---

**Try other indoor and outdoor projects from [\\_\\_\\_\\_\\_](#) !**



**Barbecue Surround**