

Bunk with the works

Your children will love this multipurpose bedroom setting

Occupying little more than two square metres of floorspace, this clever bedroom setting includes a loft-style bunk, desk, cupboard and bookshelf. Designed for children aged six to 10, it's an all-in-one solution for small bedrooms. By Dieter Mylius

Note: The bed illustrated was made for a bedroom with tall ceilings. If the ceilings in your home are 2.4m high, you'll need to reduce the height of the bunk bed. This will leave you with enough room for children up to 135cm in height to

stand under the bed, and approximately 90cm sitting room when in bed. For bedrooms with a ceiling height of 2.7m or more, the height shown will allow children up to 165cm to stand under the bed. As your child grows, the components can be separated and used individually (after cutting down the bed legs, of course).

All timber used is pine, except where noted otherwise. Bevel all rails and sharp edges before assembly. Counterbore for all screws so the heads can be covered with wood filler or wood plugs.

Bed and ladder

Step 1 On each leg (BA), cut a 25 x 25mm bevel off top inside narrow edge. Measure 200, 290, 810 and 900mm from bottom, and 260 and 350mm from top. Screw end rails (BB,BC) between these marks and one flush with top. Flip frame over, measure 350mm from top and screw on support rail (BD) so top edge is flush with mark. Make another matching end frame.

Step 2 Screw slat supports (BE) to side rails (BF) so bottom edges are flush. Stand the two end frames with end rails facing out and rest side rail assemblies on top of support rails. Clamp side rails to legs. Square up unit, making sure legs are vertical. Drill bolt holes – one through slat supports and the other 25mm from top of side rail. Counterbore bolt holes on inside of frame so nuts won't finish proud of rail surface. Add safety rails (BG) flush with top of legs, again using bolts. Space evenly and screw on slats (BH) to complete bed.

Step 3 To make the access ladder, mark 170, 470, 770, 1070, 1370 and 1670mm from top of each upright (BI). Cut a series of 70 x 10mm housings, each with its top on a mark. The shorter ladder will have one housing less. Glue and screw the six (or five) rungs (BJ) into housings after bevelling the sharp edges.

Shopping: Storage bed developed and built by **Nikos Grammenos** (02) 4751 6190. All materials from **Mitre 10** 136 310.

Bed and ladder

| Item | Part | Section size | Length & number for 2.7m ceilings | Length & number for 2.4m ceilings |
|------|-----------------|--------------|-----------------------------------|-----------------------------------|
| BA | Legs | 45 x 90mm | 2000mm (4) | 1700mm (4) |
| BB | End rails | 90 x 19mm | 1080mm (6) | 1080mm (6) |
| BC | End rails | 190 x 19mm | 1080mm (2) | 1080mm (2) |
| BD | Support rails | 40 x 19mm | 1080mm (2) | 1080mm (2) |
| BE | Slat supports | 40 x 19mm | 1950mm (2) | 1950mm (2) |
| BF | Side rails | 190 x 19mm | 1950mm (2) | 1950mm (2) |
| BG | Safety rails | 90 x 19mm | 1950mm (2) | 1950mm (2) |
| BH | Slats | 140 x 19mm | 952mm (10) | 952mm (10) |
| BI | Ladder uprights | 70 x 35mm | 1950mm (2) | 1650mm (2) |
| BJ | Rungs | 70 x 30mm | 450mm (6) | 450mm (5) |

You'll also need: 6mm cup-head bolts (eight at 65mm and four at 90mm) with washers and nuts

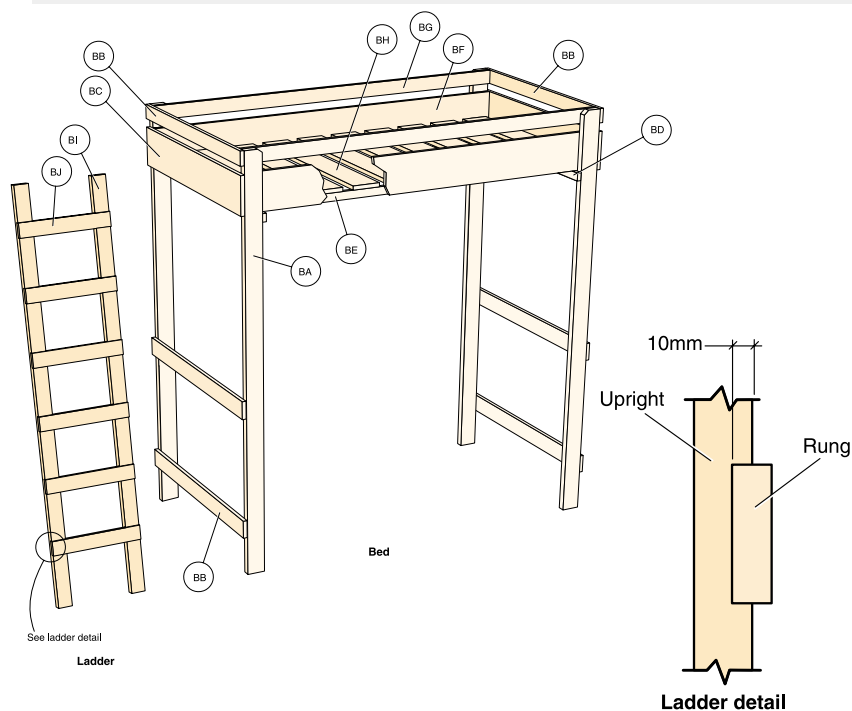

Desk

Step 4 Prepare the legs (DA) by measuring 165mm from top, and planing a small bevel down all edges from this mark to bottom of each leg. Then measure 25 and 68mm from top on two adjacent faces of each leg for the dowel holes. Use dowelling jig and 8mm drill bit to bore 20mm-deep holes in centre of each leg at these marks.

Step 5 Cut long and short rails (DB,DC) and on ends mark 25 and 68mm from top to match legs. Bore 8 x 20mm-deep dowel holes. Apply glue to holes and mating faces, then insert dowels and tap legs to rails. Measure diagonals to check everything is square. Hold with clamps, then glue and screw on corner blocks (DD) flush with top of rails.

Step 6 To edge-glue halves of desk top (DE) together using dowels, just butt the two pieces together, then square lines spaced 150mm apart across both pieces. Use these marks to align the dowelling jig. Alternatively, use a biscuit joiner. Remove excess glue and, when dry, place face down on a bench. Centre leg assembly between ends but with back legs flush to back edge of top. Screw on through corner blocks after predrilling and counterboring. Fit desk between bed legs at one end, and screw through bottom end rail of bed into desk legs if required.

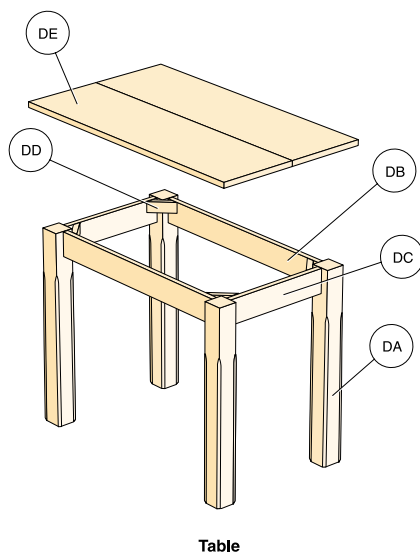

Desk

| Item | Part | Section size | Length & number for 2.4 and 2.7m ceilings |
|------|---------------|--------------|---|
| DA | Legs | 70 x 70mm | 720mm (4) |
| DB | Long rails | 90 x 19mm | 760mm (2) |
| DC | Short rails | 90 x 19mm | 400mm (2) |
| DD | Corner blocks | 40 x 19mm | 105mm (4) |
| DE | Desk top | 290 x 19mm | 985mm (2) |

You'll also need: sixteen 8 x 38mm dowels

Cupboard

Step 7 Glue sides (CA) together using dowels or biscuit joints, then wipe off excess glue. Clean up joints once glue has set, then mark out housing for bottom and mid shelves. The undersides of shelves are located 50 and 420mm from base of unit. Set up a straight edge to run a router, with a 19mm straight bit, to cut a housing depth of 5mm. The bottom housing is stopped about 5mm short of front and mid housing, 25mm from front.

Step 8 Screw on cleats (CB) so top cleats are flush with top and centred on each side. The lower ones are flush with bottom of housing and back.

Step 9 Glue halves of bottom shelf (CC) together, then cut a 15 x 5mm notch at both front corners. When fitted into side housings, the result will be a neat vertical join line on the face. Predrill sides and glue and screw in place. Repeat for central shelf (CD). Add the two front rails (CE) by screwing from sides into rails. Fix back rail (CF) in a similar way.

Step 10 Glue halves of top (CG) together and let dry. Centre on cupboard so back is flush with cabinet. Screw on from underside through rails and cleats. Before fitting plywood back (CH), check diagonals to see if cupboard is completely square. Nail on the back.

Step 11 Dowel door stiles (CI) to rails (CJ), check they're square, then let dry. Round over inside front edges and rout a 10 x 3mm-deep housing in back to take plywood panels (CK). Fit door to cupboard with 75mm flush hinges spaced 120mm from top and bottom.

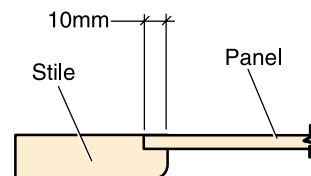

Door detail

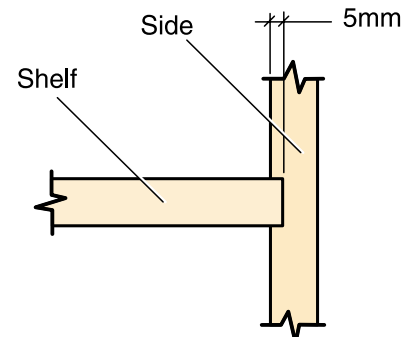

Shelf detail

Bookshelf

Note: The bookshelf is built similarly to the cupboard but without doors.

Step 12 Rout stopped 5mm-deep housings in sides (SA) so that underside of shelves (SB) will be located 250 and 500mm from bottom of unit to accommodate tall ceilings. If you're making the smaller bookshelf, install only one shelf, spaced 230mm from base. Notch front of shelves to suit housing, as for cupboard, then screw sides to shelves.

Step 13 Screw rails (SC) between sides at back top and bottom, as well as at top front rail (SD). Add plywood top (SE), then evenly space lining slats (SF) across back and screw to back rails.

Step 14 Locate bookshelf on top of cupboard. Measure the top trim (SG) to clear the bed legs, and mitre the front corners.

Bookshelf

| Item | Part | Section size | Length & number for 2.4m ceilings | Length & number for 2.7m ceilings |
|------|--------------|--------------|-----------------------------------|-----------------------------------|
| SA | Sides | 290 x 19mm | 750mm (2) | 450mm (2) |
| SB | Shelves | 290 x 19mm | 950mm (2) | 950mm (1) |
| SC | Back rails | 90 x 19mm | 940mm (2) | 940mm (2) |
| SD | Front rail | 40 x 19mm | 940mm (1) | 940mm (1) |
| SE | Plywood top | 290 x 3mm | 978mm (1) | 978mm (1) |
| SF | Slat linings | 130 x 12mm | 750mm (8) | 450mm (8) |

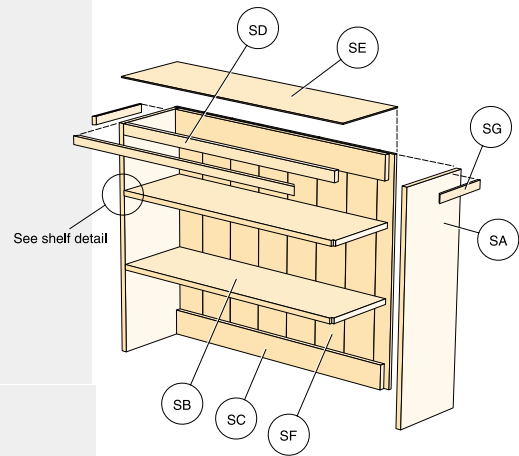

Cupboard

| Item | Part | Section size | Length & number for 2.4m and 2.7m ceilings |
|------|----------------|--------------|--|
| CA1 | Sides | 290 x 19mm | 830mm (2) |
| CA2 | Sides | 90 x 19mm | 830mm (2) |
| CB | Cleats | 40 x 19mm | 342mm (4) |
| CC1 | Bottom shelf | 290 x 19mm | 950mm (1) |
| CC2 | Bottom shelf | 90 x 19mm | 950mm (1) |
| CD1 | Mid shelf | 290 x 19mm | 950mm (1) |
| CD2 | Mid shelf | 70 x 19mm | 950mm (1) |
| CE | Front rails | 40 x 19mm | 940mm (2) |
| CF | Back rail | 140 x 19mm | 940mm (1) |
| CG1 | Top | 290 x 19mm | 985mm (1) |
| CG2 | Top | 140 x 19mm | 985mm (1) |
| CH | Plywood back | 978 x 3mm | 849mm (1) |
| CI | Door stiles | 70 x 19mm | 717mm (4) |
| CJ | Door rails | 90 x 19mm | 327mm (4) |
| CK | Plywood panels | 347 x 3mm | 557mm (2) |

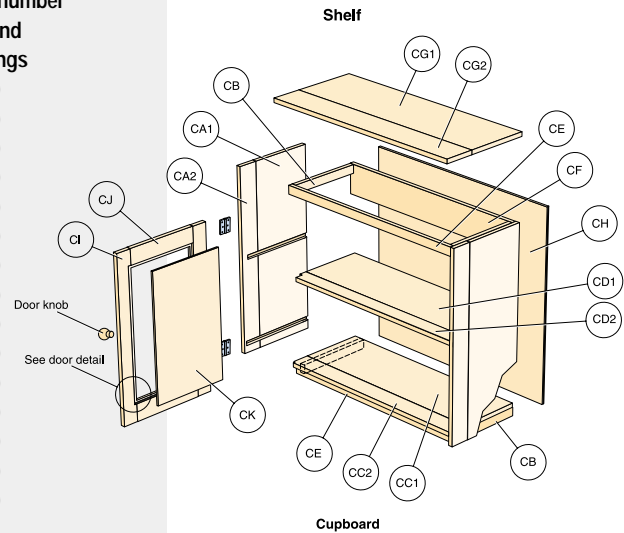

You'll also need: four 75mm flush hinges; two knobs

