

How to Make a Faux Flower Vase

This flower vase is easy to make and can be completed in a relatively short time.

It can be filled with dry flowers and plants that can adorn any room in the home. Also the Faux technique, on the exterior, can provide the opportunity to express one's artistic, as well as creative talents.



FAUX DRY FLOWER VASE

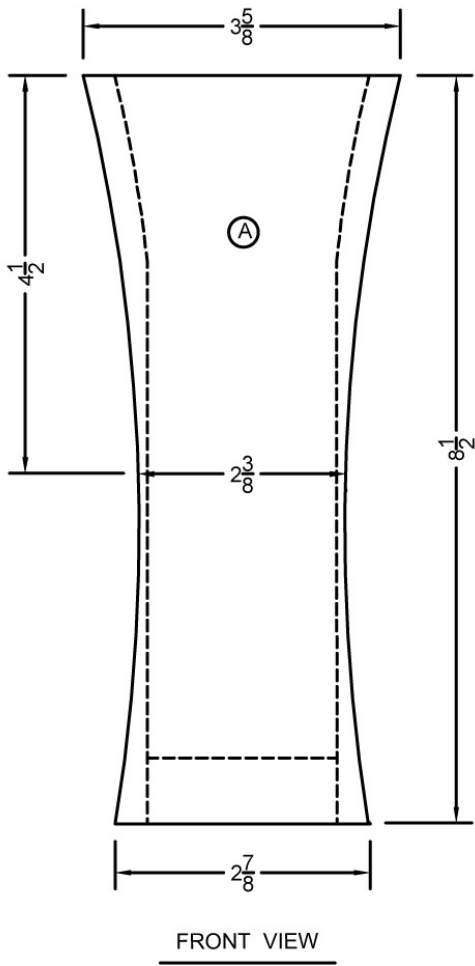
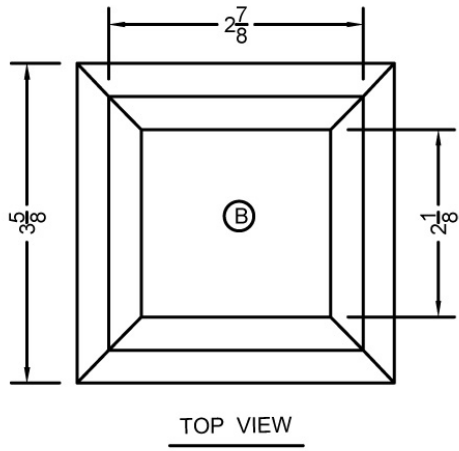

Technical Information for Making a Flower Press

A. Materials List:

QUANTITY	LETTER	NAME	SIZE	MATERIAL
4	A	Slides	3/8" x 3 5/8" x 8 1/2"	Notty Pine
1	B	Base	3/4" x 2 1/8" x 2 1/8"	Notty Pine
WOOD SPECIES				
				
Pine				

B. Cutting & Gluing Procedures:

1. Use a 1" x 8" x 24" knotty pine board for this project.
2. Joint one face and one edge of the board..
3. Plane the board to 3/4" thickness.
4. Use a table saw to cut out the 4 Sides (A) each equal to 3 5/8" x 8 1/2".
5. Adjust the table saw blade to 45 degrees and cut a bevel on both edges of the 4 sides.
6. Measure down 2" from the top/inside portion of each side (A) and draw a pencil line
7. Draw a pencil line across the top end of each side (A) 3/8" from the inside surface.
8. Use a band saw to cut off the top/inside corner between the two pencil marks on each side piece.
9. Clean the sawdust from the sides with a tack rag.
10. Glue the edges of each side (A) with woodworking glue, and clamp the sides together with 3 band clamps.
11. Clean the excess glue with a damp rag.
12. Adjust the table saw fence 2 1/8" from the saw blade and cut the base (B) 2 1/8" square.
13. Remove the saw dust from the base (B) with a tack rag.

14. Place glue on the edges of the base and insert it flush into the bottom of the vase.
15. Remove the excess glue with a damp rag, and allow the glue to dry for 24 hours.
16. Remove the clamps and trace the exterior shape of the vase onto each side.
17. Use a band saw to cut the exterior shape of the vase on each side. Start each cut at the top/exterior edge of the vase.
18. Use a spindle sander to sand each side of the vase smooth.
19. Rough sand the vase by hand with 80 grit sandpaper.
20. Intermediate sand the vase by hand with 120 grit sandpaper.
21. Finish sand the vase by hand with 220 grit sandpaper.
22. Round off the top and the side edges with sandpaper.
23. Thoroughly clean all surfaces of the vase with a tack rag.

C. Finish Procedure:

1. Use a flat natural bristle brush to coat the exterior surfaces of the vase with a light brown, oil base, gloss enamel paint.
2. FAUX paint wood grain and high-lite areas with a darker brown with an oil base, gloss enamel paint. The highlighting and wood grain patterns should be done with a pen stripe brush. Thin the darker paint slightly with mineral spirits for easier application.
3. Apply clear gloss enamel over the FAUX design with a flat brush.
4. Allow the paint to dry for 24 hours.
5. Lightly hand sand the clear coat with 220 grit sandpaper.
6. Remove the sanding dust with a tack rag.
7. Apply a second coat of the clear gloss enamel.
8. Allow the second coat to thoroughly dry for 48 hours.
9. Insert the dry flower arrangement into the vase.

***Congratulations, your custom decorative fireplace mantel is finished and ready to use**