

155

MANTLE CLOCK

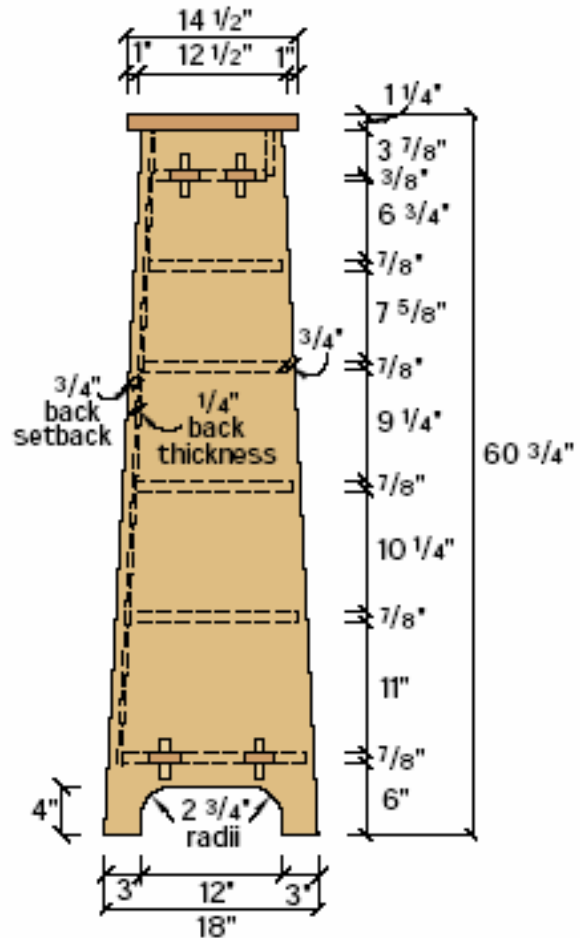

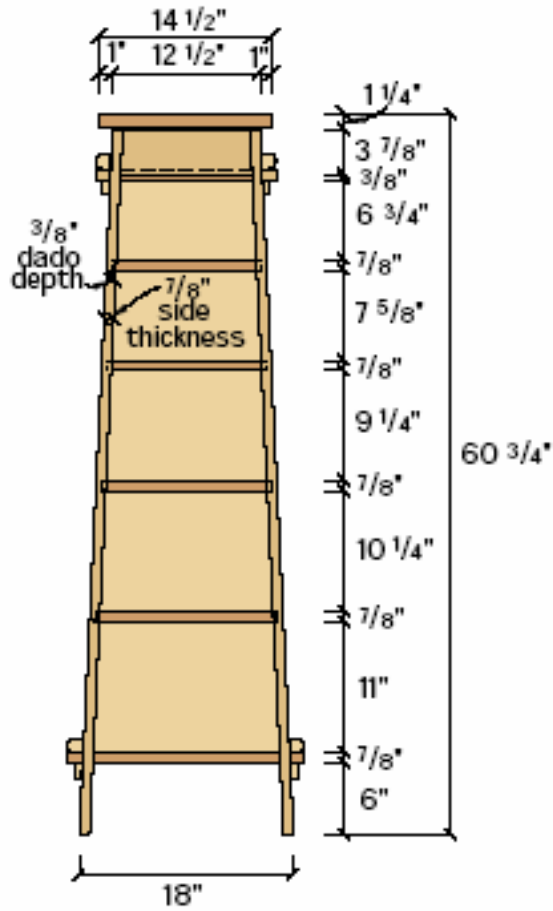
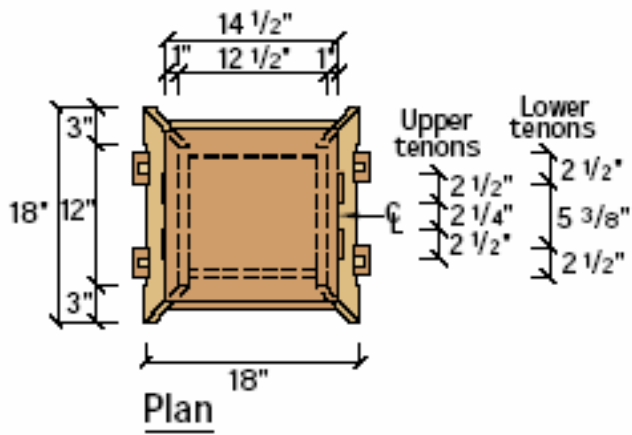

During the Arts & Crafts heyday at the turn of the 20th century there were an extraordinary number of designs for bookcase and magazine stands offered to the public as completed pieces and construction plans. Most included simple designs and straightforward construction.

Slabs • In keeping with the Arts & Crafts style of stout furniture, the sides and shelves of this piece are called out as 7/8"-thick material. You may find the design more economically feasible by changing that to 3/4" material. Start by milling and matching the grain patterns on the two side pieces. If possible, try and use only two boards per side for the width. If this isn't possible, the trapezoidal design will allow you to use two 7"-wide boards for the center of each side, adding a 2" strip on the front and back edges of the lower half, keeping the exposed glue lines to a minimum.

With the sides glued, squared up and sanded flat, mark the location of the shelves as shown on the diagram. The top and bottom shelves will have angled through-mortises cut into the sides, while the other four shelves are captured between the sides in 3/8"-deep stopped dadoes. To mark the start and stop locations of the dadoes, draw the shape of the sides on the side blanks, then measure in 3/4" from the front and back edges.

Cut the dadoes with a plunge router and a router guide. Even though the sides of the stand are angled 3 degrees, the dadoes can be cut at a 90-degree angle to the side leaving only a slight gap on the underside of each shelf. If you prefer to eliminate the gap, a wood strip can be used to tilt the router at a 3-degree angle. If you opt for the angled dadoes, run a test piece or you may inadvertently transfer your gap to the top of the shelf.

The through-mortises can also be cut using a router with the base tilted to a 3-degree angle or marked and hand cut. In either case, cut from the outside surface to keep any tearout to the inside of the case. Use a scrap backing board to reduce the tearout even further.

Trapezoids & Shelves • With the dadoes and through-mortises complete, crosscut the top and bottom edges of the sides at a 3-degree angle, then use a band saw or a jigsaw and a plane to shape the sides. Next, mark and cut the elongated half-oval at the base of each side to form the legs. Lastly, mark the back edge of each side for a 1/4" wide x 3/8" groove for the back. The groove should be set in 1/2" from the back edge and start 6" up on the sides, running through at the top.

Next cut the shelves to size. The four center shelves can be cut to the sizes given in the Schedule of Materials, with all four edges cut on a 3-degree angle. The top and bottom shelves are a little more complicated. Each must have the through-tenons cut to size and shape.

And the end of the shelf should be pared with a chisel on a 3-degree angle to match the inside surface of the sides. Don't cut the mortises for the wedges at this time. See the wedge diagram on the next page.

Back & Drawer • This next step can be a little awkward, so if you have a friend handy, give him or her a call. Dry-assemble the stand

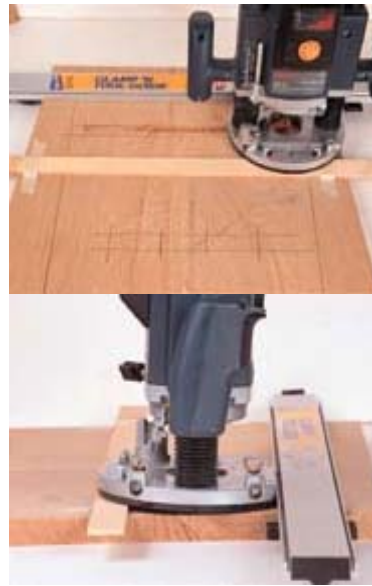

MILL THE SIDES • A 1/4"-thick strip of wood is taped in place on the side slab to give a 3-degree angle to the shelf dadoes and the through mortises. Using a 1/2" straight router bit required moving the set-up once for each dado to achieve the 7/8" width necessary.



TAPERS EVERYWHERE • The sides are tapered only after all the necessary milling in the sides is completed. I used a jigsaw to cut the sides to size, then smoothed up the edges with a bench plane.



DRAWER • The drawer is made of 1/2" Baltic birch plywood, and it uses tongue-and-groove construction. A more complex joint could have been used, but the drawer is unlikely to see any heavy use and could be left out altogether.

by laying one side flat so the through-mortises hang over the edge of the table. Place the shelves in their respective dadoes and insert the through-tenons into the mortises. Then place the other side over the tenons and insert the shelves. To hold everything in place, use soft-jawed clamps across the width of the stand placed underneath the through-tenons. This should pull the tenons and the shelves into place. Check the fit and adjust as necessary.

With the stand still dry-assembled, measure for the trapezoidal back, allowing as tight a fit in the back grooves as possible. The bottom of the back will overlay the back edge of the bottom shelf and be tacked in place to the shelf. The top of the back should be flush to the top of the sides.

With the stand still dry-assembled, mark the location of the sides on the top and bottom surfaces of the shelf tenons extending through the sides. Then disassemble the stand and drill out or hand cut through-mortises through each tenon to accept the wedges. Note that the inside edge of the mortise should be 1/8" or so inside your marks to allow the wedges to draw the stand up tight. The diagram at right shows how the joint works. Cut the wedges a little oversized, reassemble the stand and fit the wedges in place. Make sure you mark the wedges so you'll be able to reassemble the piece easily.

If you hadn't noticed, this stand includes a little drawer just below the top. While not of a size to store a great many things, it's a good place for hiding an extra set of keys. The drawer itself is of simple box construction using tongue-and-groove joinery with a bottom captured in a groove. The angled sides of the stand serve as indexing runners to keep the drawer centered left-to-right. The drawer face is cut to match the shape of the sides and overlaps the top shelf, which serves as a drawer stop. Screw the face to the drawer box from the inside.

Topping Things Off • The top is a simple slab of wood that is attached to the sides by dowels. I carefully drilled dowel locations in the tops of the assembled sides, I then used dowel centers placed in the holes to locate the mating locations on the underside of the top piece. With the top fit, disassemble the stand again and sand all the pieces through 220 grit. As a finish for the piece I first applied a coat of brown mahogany gel stain. When the stain was dry, I applied a coat of clear lacquer, sanded and then applied a coat of warm, brown glaze. After the glaze had dried overnight, I added two more coats of lacquer. Assemble the stand as you did during the dry fit, tapping the wedges in place to hold the stand tightly together. If you plan on ever disassembling the piece, use a couple of screws to attach the back to the lower shelf and to the two center shelves for support. Then slip the top into place over the dowels. If you won't be disassembling the piece, use brads to attach the back and add some glue to the dowels to secure the top. PW

Schedule of Materials: Magazine Stand

No.	Item	Dimensions	Material
1	Top	1-1/4" x 14-1/2" x 14-1/2"	White Oak
2	Sides	7/8" x 18" x 59-1/2"	White Oak

1	Bottom Shelf	7/8" x 15-9/16" x 20"	White Oak
1	Shelf	7/8" x 14-5/16" x 15-7/16"	White Oak
1	Shelf	7/8" x 13-3/16" x 14-3/8"	White Oak
1	Shelf	7/8" x 12-1/8" x 13-7/16"	White Oak
1	Shelf	7/8" x 11-1/4" x 12-11/16"	White Oak
1	Top Shelf	7/8" x 9-1/2" x 15-5/16"	White Oak
8	Wedges	3/4" x 1-1/4" x 3-1/2"	White Oak
1	Back	1/4" x 16" x 53-1/2"	White Oak ply
1	False drw front	3/4" x 3-7/8" x 10-9/16"	White Oak
2	Drw sides	3/4" x 3" x 8"	Baltic birch
2	Drw ends	3/4" x 3" x 9-1/4"	Baltic birch
1	Drw bott	1/4" x 7-1/2" x 9-1/4"	Baltic birch