

NOTICE
The purchaser agrees when purchasing this plan (the "Plan"):
1) that the purchaser has acquired the right to build and construct the object of the contract shown in the Plan (the "Project") for his/her/its personal use only and not for any commercial use; the Plan in whole or in part by any means whatsoever is not to be reproduced;
2) that the purchaser shall not be liable for any willful misuse or negligent use of this plan, the Project, or any tools used to construct the Project, or for any loss or damage resulting therefrom. *

NOTES: Read all directions before beginning.
Dimensions shown in brackets denote millimeters.
Set all nails, Countersink all screws.

Directions

- 1) Lay out your material as outlined in the suggested material layout (Fig. 1). Draw out all parts exactly as illustrated, including the letter designations, in pencil. Ensure to leave a small space between cut lines to allow for the width of the saw. Before cutting double check all measurements to ensure they are correct. Always cut on the waste side of the line. Initially, only cut the plywood (A) in half as shown. Further cuts will occur in instruction 6.
- 2) Place three of the four pieces C together and clamp with two bar clamps. Ensure all the ends of the pieces are flush, and starting at the bottom, mark one of the pieces every 3" (Fig 2). This will ensure that all of your shelves will sit level. Remove bar clamps and mark each piece from top to bottom with a 3/4" centre line. This mark should be on the same face as previous marking. This will give you the exact centers for drilling your holes. Drill the holes with a 1/4" bit (assuming your brackets are 1/4" diameter), using the depth gauge (illustration 1), to achieve a 1/2" depth.
- 3) Now clamp the pieces together again adding the fourth piece C. Be sure previously marked lines are facing sides. Now you only need to drill 40 3/8" holes. From the top, measure down 1 7/8" and 2 5/8". As outlined above, draw your line across all four pieces and centre mark the lines. Drill all the way through the posts with a 1/8" bit.
- 4) Uncrimp and lay out two of the twice drilled pieces as shown (Fig 3). Countersink the holes that go through completely from the outside with a 3/8" drill bit, 1/2" deep. Put some glue on the ends of pieces B and attach to the pieces C with #8 2" flathead screws as shown (Detail 1 & 2, Figure 3). Force 3/8" dowel, cut to a 1/2" length, into countersink holes as shown (Detail 2). Sand off any dowel still sticking out. Repeat this process for the other shelf support, ensuring that the twice drilled piece C is on the left, and the once drilled piece is on the right. Wipe off excess glue.
- 5) Lay the side supports you have built on top of each other and attach the hinges as is shown (Fig 4) 6" from top and bottom using 1" #8 flathead screws.

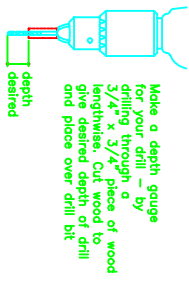

DRILL DEPTH GAUGE ILLUSTRATION 1



For three pieces only
Drill holes 1/4" dia
X 1/2" deep

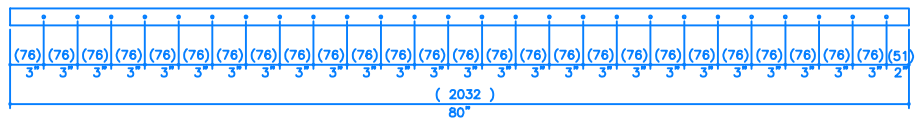

FIGURE 2

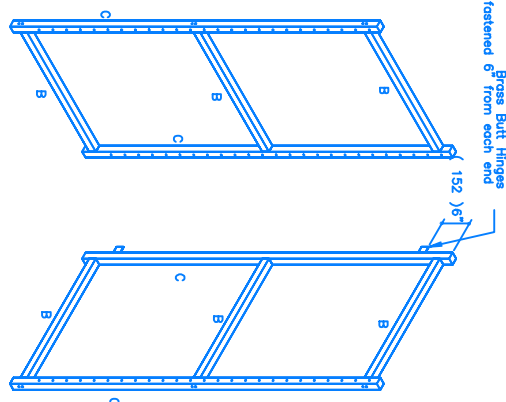
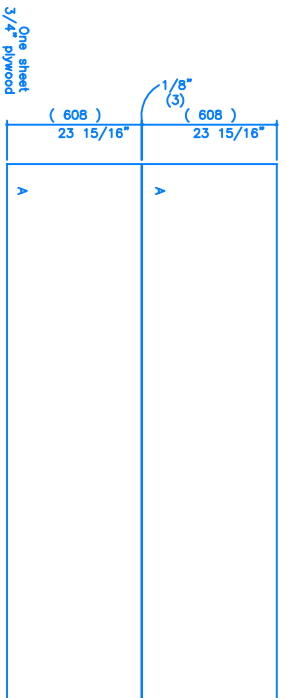
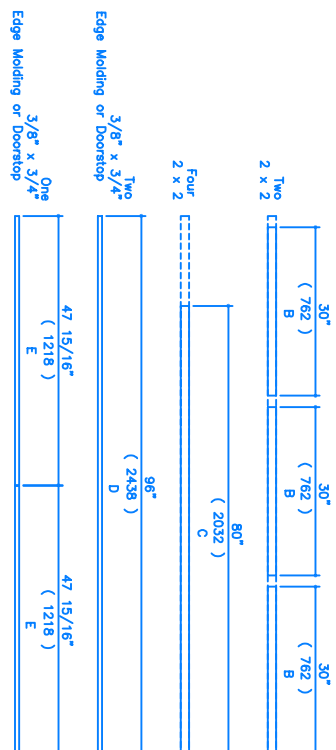

FIGURE 4



One sheet
3/4" plywood



MATERIALS LAYOUT FIGURE 1

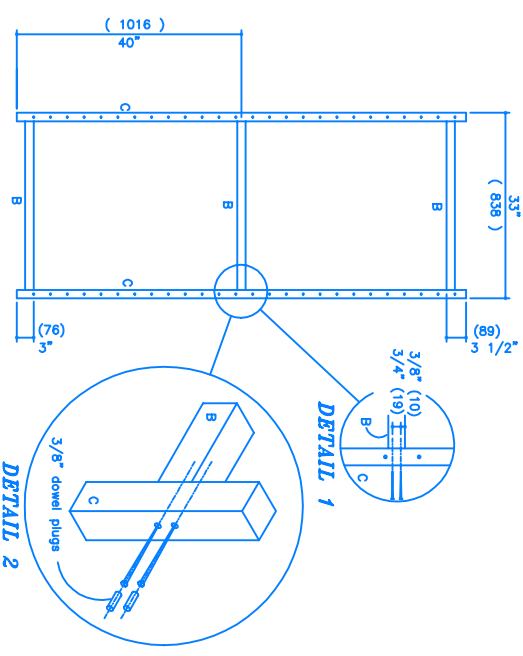
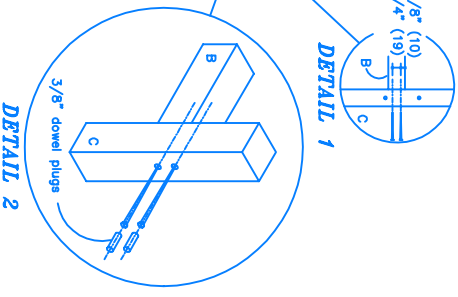

FIGURE 3



DETAIL 2

CORNER SHELVES – Project #803

MATERIALS LIST
Eighteen shelf support brackets
Three 8" doorstop (3/8 x 3/4") or edge moulding
Approx. thirty 2" #8 flathead screws
Approx. 1 1/2 lb. 3/4" finishing nails
Four 1/2" brass butt hinges
Four 1/4" brass dowel pins
16" of 3/8" wood doweling or twenty four 3/8" dowel plugs

MATERIALS LIST
One 4'x8' sheet 3/4" plywood
Six 8' 2x2 (1 3/4 x 1 3/4")
Approx. thirty #8 1" flathead screws
TOOLS
Pencil and Measuring Tape
Table Saw and Power Drill
Hammer and Screwdrivers
1/8" Bar Clamps
1/8" 1/4" & 3/8" Set
Square and Nail Set