

SANDING BLOCK

This is one of those tools that is very basic, yet has unlimited uses. The sanding belt material is so durable, that it can be used on practically any material. It is especially handy when working with formica.

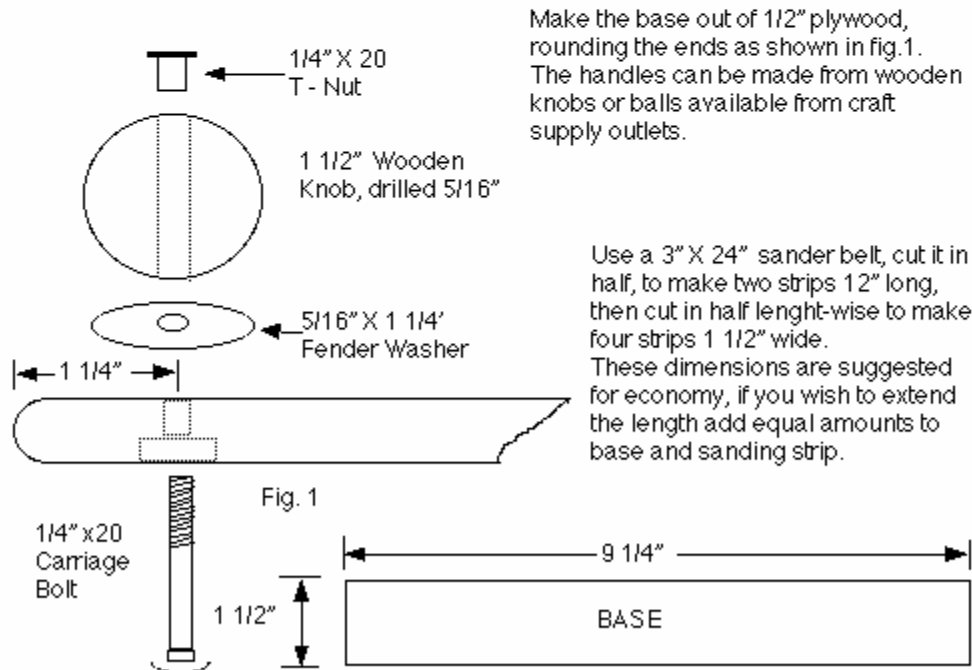
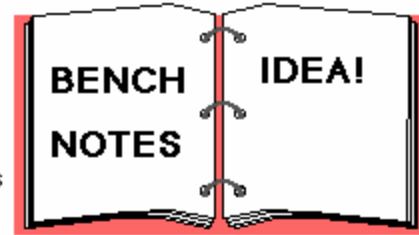

To install the belt push one end under the fender washer and tighten knob, wrap belt around base and over other end under second fender washer, tighten second knob.