



Step Stool

Use this handy stool anywhere around the house. Easily get at out of reach places and provide an extra boost for the youngsters. Constructed from your favorite wood, this stool can be made from some of those scraps you've been saving in your shop.

Dimensions:

14-1/2" High x 17" Wide x 14" Deep.

Getting started:

The parts for this project can be cut with a variety of tools and machines but we all have our favorites and those of which we are most comfortable. We suggest you read through the instructions before doing any cutting and decide which tools you feel most comfortable using. The plan is designed to guide you through the steps of building the project as we have.

Shop tips:

We have a few helpful hints we would like to share with you that have made assembling projects easier for us and help you to have the same success and enjoyment.

Predrilling is always a good idea in any type of wood that you use to avoid splitting or breaking off screw heads.

You can't say enough about squaring up assemblies no matter where you are in the assembly process. Getting something a little out of skew can be a frustrating experience for any woodworker. To avoid this always keep a tape measure and square handy. Remember to square before and after you have tightened the clamps.

All of the parts in this plan have been given a part number so they can be easily identified in the assembly instructions. When cutting out parts it is helpful to mark the part number (in pencil) on that part so when it comes time for assembly you can easily identify that specific part.

A note about safety:

Woodworking can be dangerous. Safety equipment and keeping your tools in proper working order with guards in place and adjusted properly can greatly reduce your risk of injury.

Be sure to read and understand all of the safety instructions that come with your tools.

Use common sense and caution in your workshop at all times. If you are not comfortable with a procedure, don't do it. Find an alternative that feels safe for you, no matter how others may work. Safety in your workshop is your responsibility.

Thank you for trying FurniturePlans.com.

If you have specific questions or problems regarding any of our plans, you may e-mail us at:

Tech@furnitureplans.com

If you have any general comments or suggestions, please e-mail us at:

info@furnitureplans.com

We'll be happy to hear from you.

CUT LAYOUT

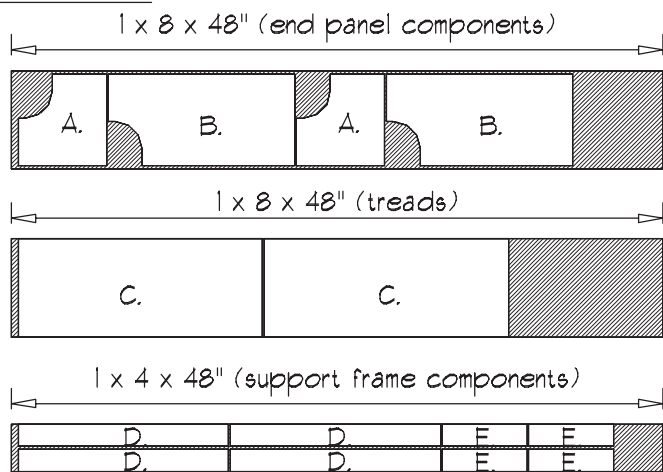

MATERIALS LIST: HARDWARE LIST:

- (1) 1 x 8 x 96"
- (1) 1 x 4 x 48"
- (8) #8 x 2" flathead wood screws
- (8) #10 x 1-1/4" flathead wood screws
- (8) #10 x 2" flathead wood screws

PARTS CUT LIST: (finished dimensions)

- A. (2) 6-3/4" x 7" (end panel)
- B. (2) 6-3/4" x 14-3/4" (end panel)
- C. (2) 7-1/4" x 18" (treads)
- D. (4) 1-5/8" x 15-1/2" (support frame)
- E. (4) 1-5/8" x 6-1/4" (support frame)

DIAG 1. CUT AND GLUE END PANELS

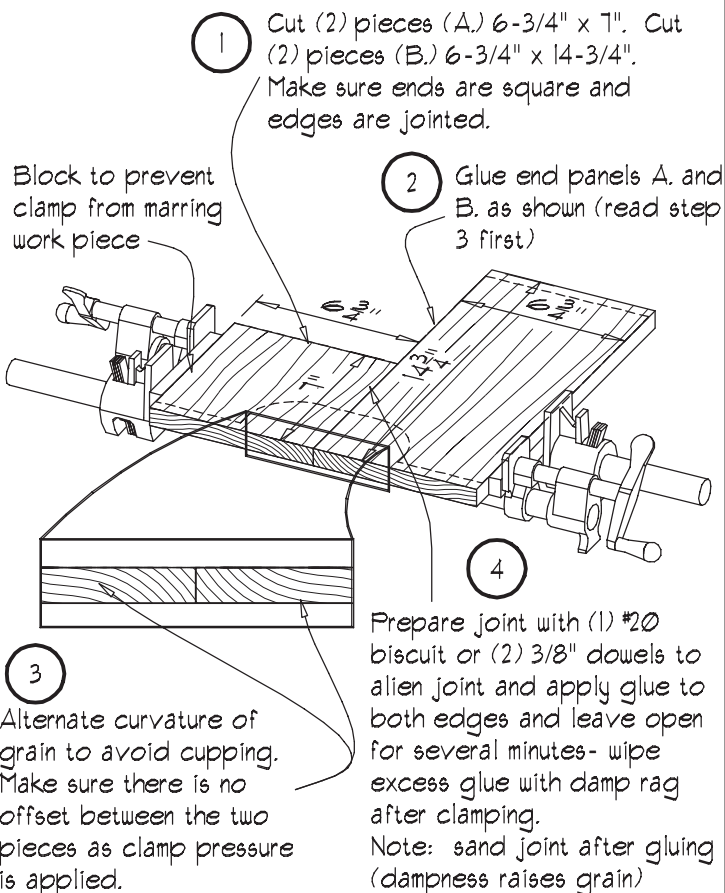

DIAG 2. END PANEL COMPOSITE- CUT TO SIZE

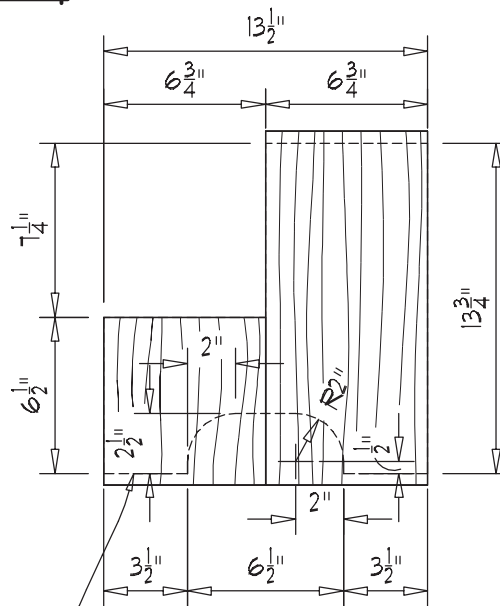

Square both ends on the tablesaw, beginning with bottom, and making the final cut to finished length at the top

DIAG 3. MARK AND CUT END PANEL

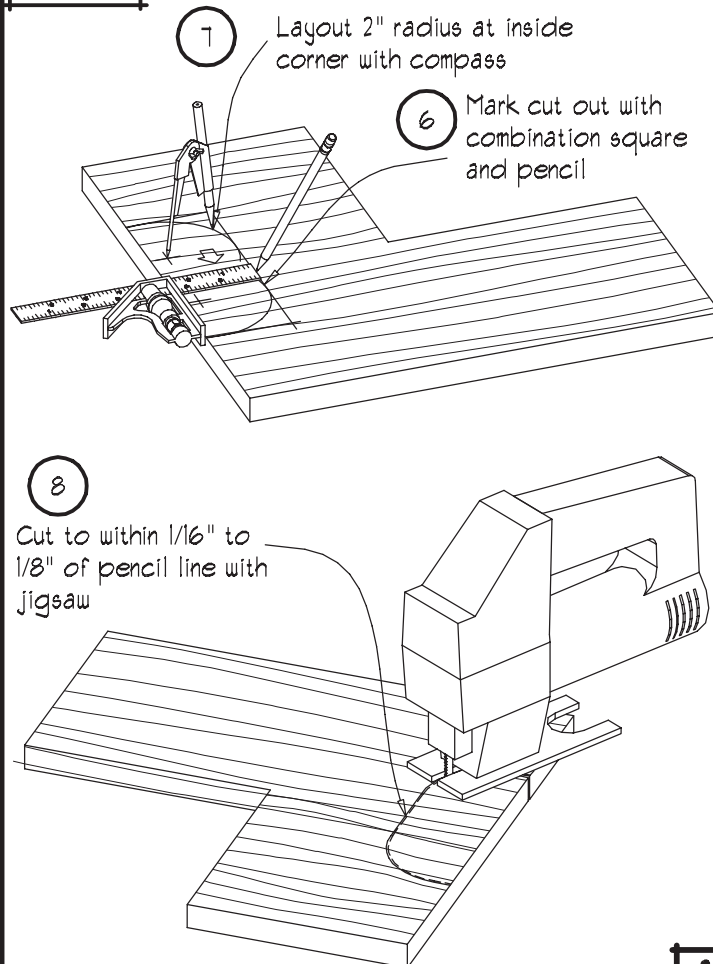

DIAG 4. SANDING CUT OUT

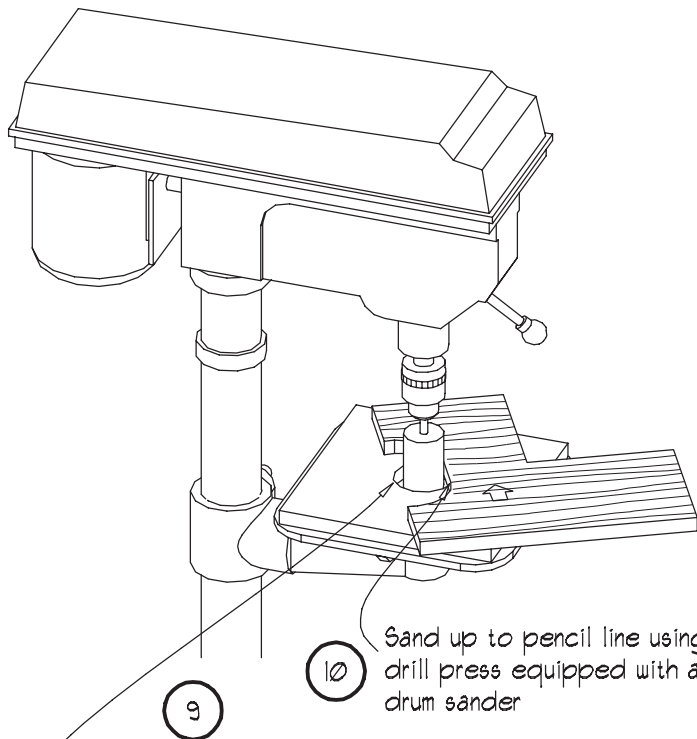

9 Drill a hole larger than the diameter of the drum sander in a piece of scrap which can be attached to drill press table with double faced tape or backscrewed from underneath

10 Sand up to pencil line using drill press equipped with a drum sander

DIAG 6. CUT AND ROUT STEP TREADS

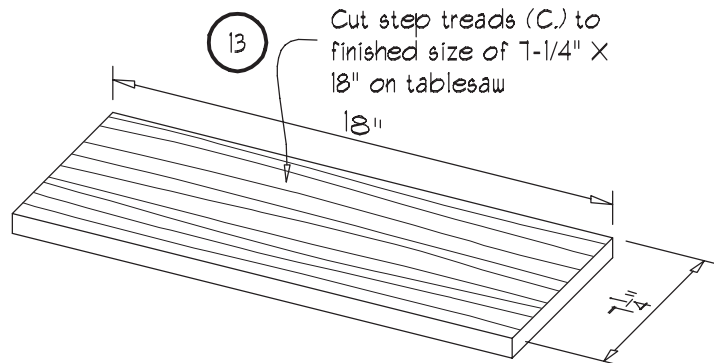

13 Cut step treads (C.) to finished size of 7-1/4" X 18" on tablesaw

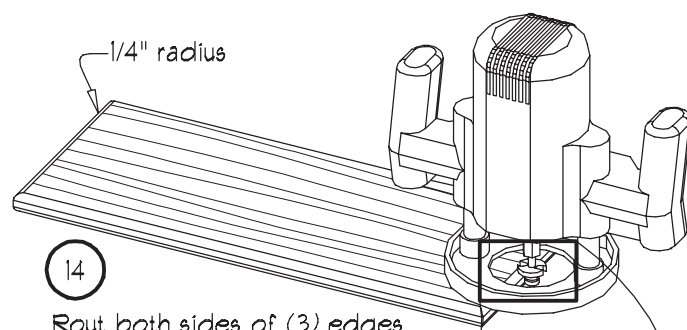

14 Rout both sides of (3) edges with 1/4" radius roundover bit (move router counterclockwise around work piece)

DIAG 5. CUTTING SECOND END PANEL

11 Clamp both end panels to corner of workbench, with finished piece on top of rough cut piece. (note: invert pieces if a flush trim bit is used in place of a pattern bit)

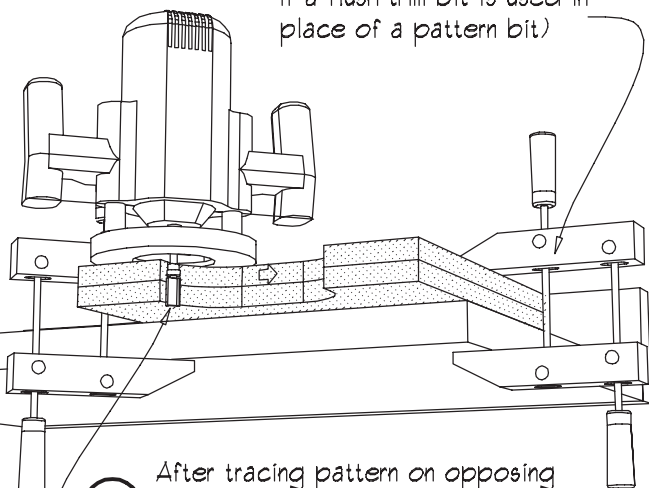

12 After tracing pattern on opposing end panel and rough cutting with jigsaw (as in step #8) trim second end panel using a router with a 1/2" x 1" pattern bit. (This step is optional, but will insure both cutouts are exact.)

Prepare for assembly:

Now is the best time to give all the pieces (including the stock to be used for the support frame) a final sanding and prepare for final assembly.

Start with 150 grit sandpaper to remove all the tool marks and work your way through to 220 grit until the surface is smooth.

If you plan to use water based stain to finish the shelf, it is a good idea to lightly wet the wood surface with a damp cloth before the final sanding with 220 grit paper. This will raise any grain that would otherwise raise when a water based finish is applied.

DIAG 7. CUT AND RABBET TREAD SUPPORTS

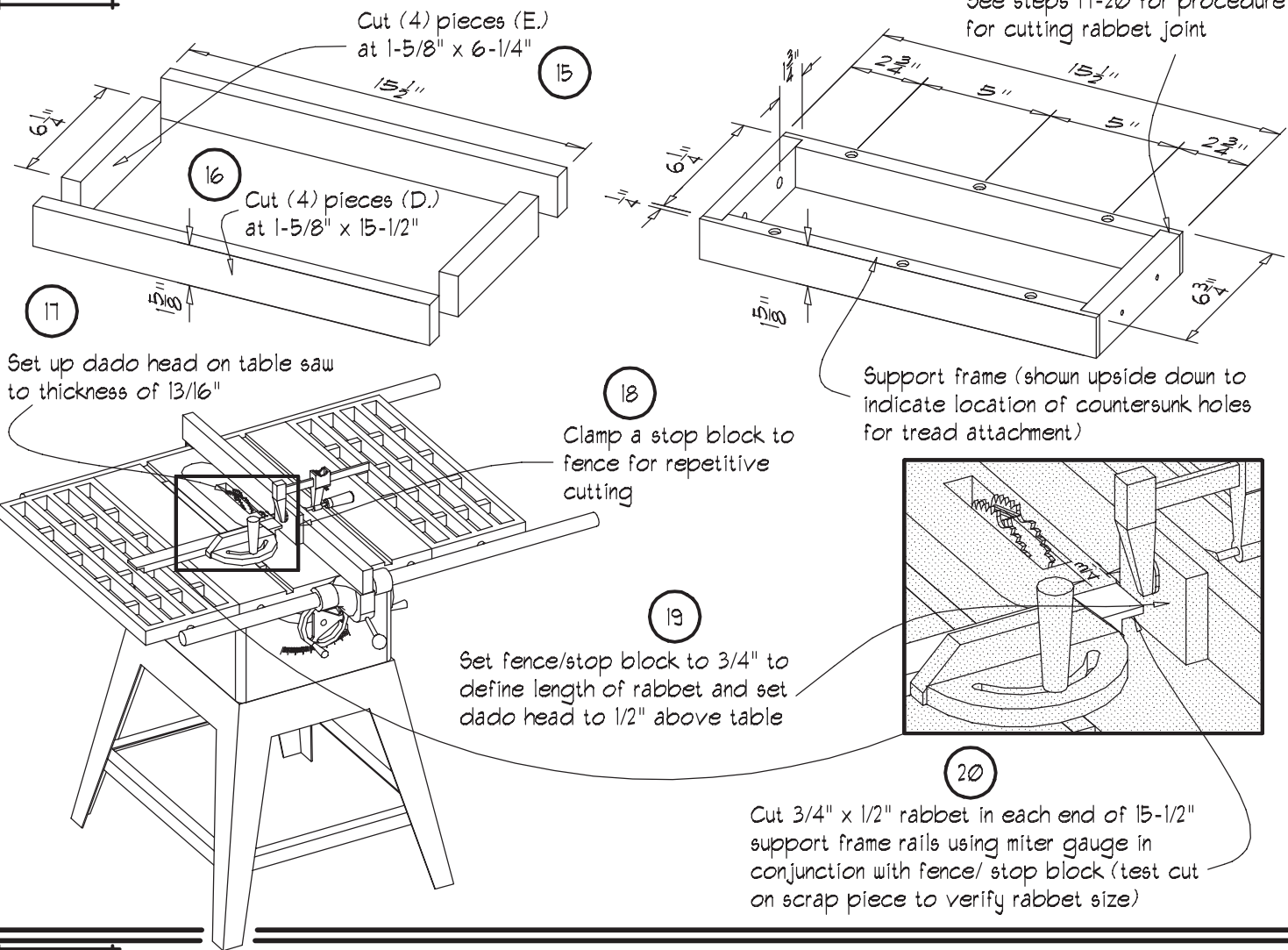

DIAG 8. DRILL AND ASSEMBLE FRAME

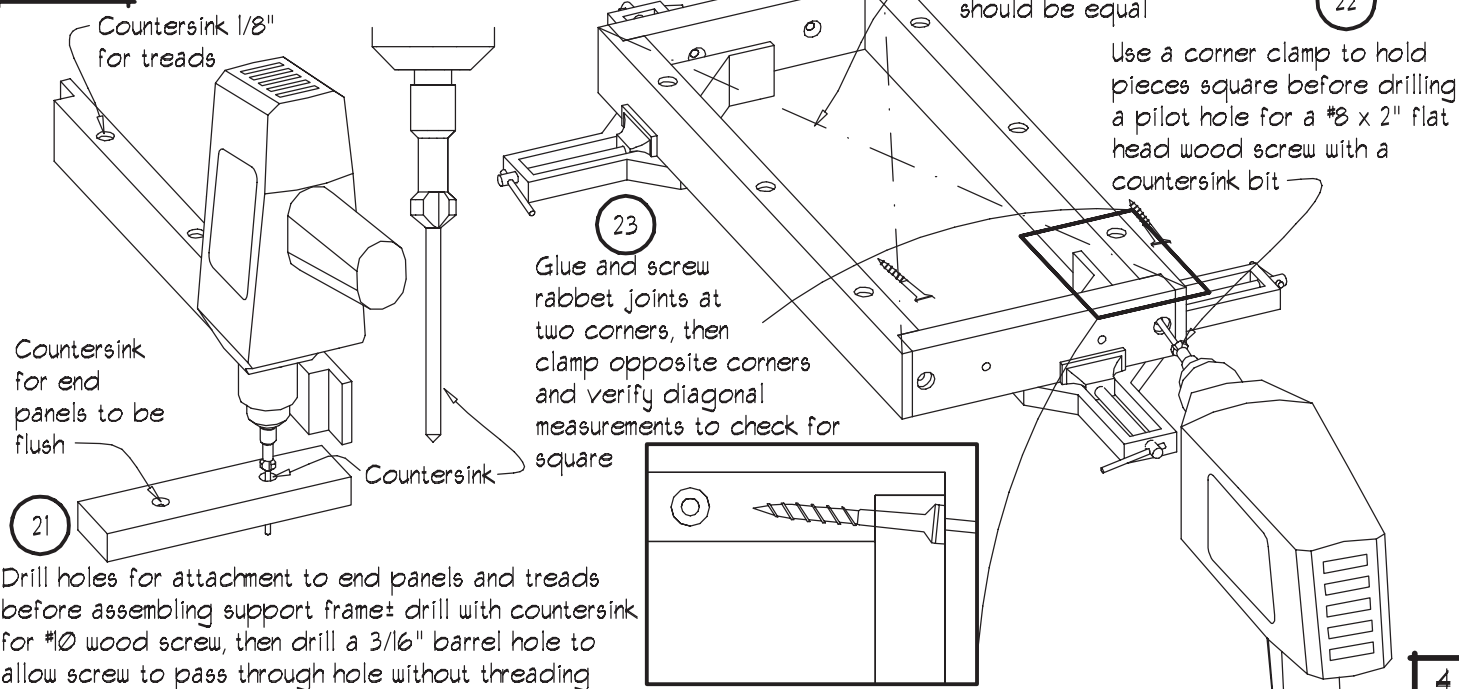

DIAG 9. ASSEMBLE FRAMES TO END PANELS

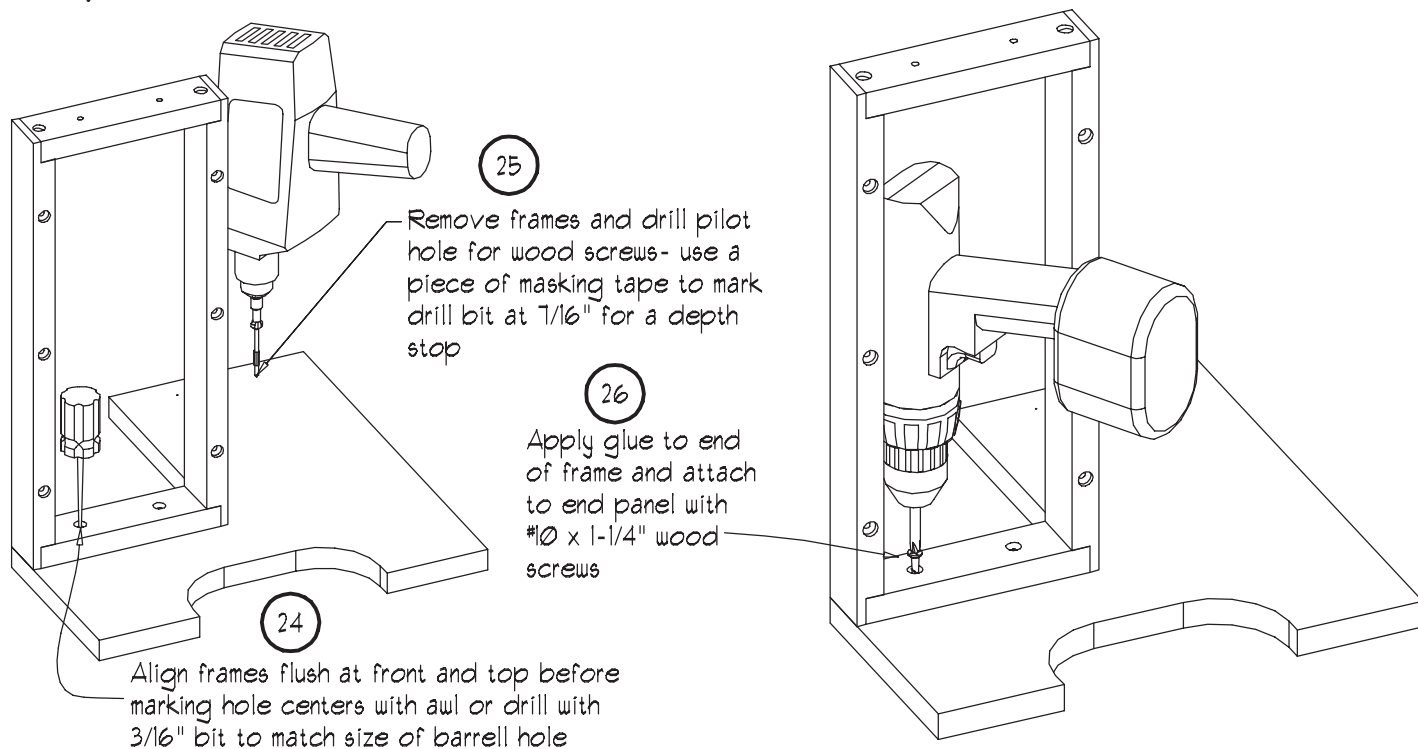

25

Remove frames and drill pilot hole for wood screws- use a piece of masking tape to mark drill bit at 7/16" for a depth stop

26

Apply glue to end of frame and attach to end panel with #10 x 1-1/4" wood screws

24

Align frames flush at front and top before marking hole centers with awl or drill with 3/16" bit to match size of barrel hole

DIAG 10. ATTACH TREADS TO SUPPORT FRAME

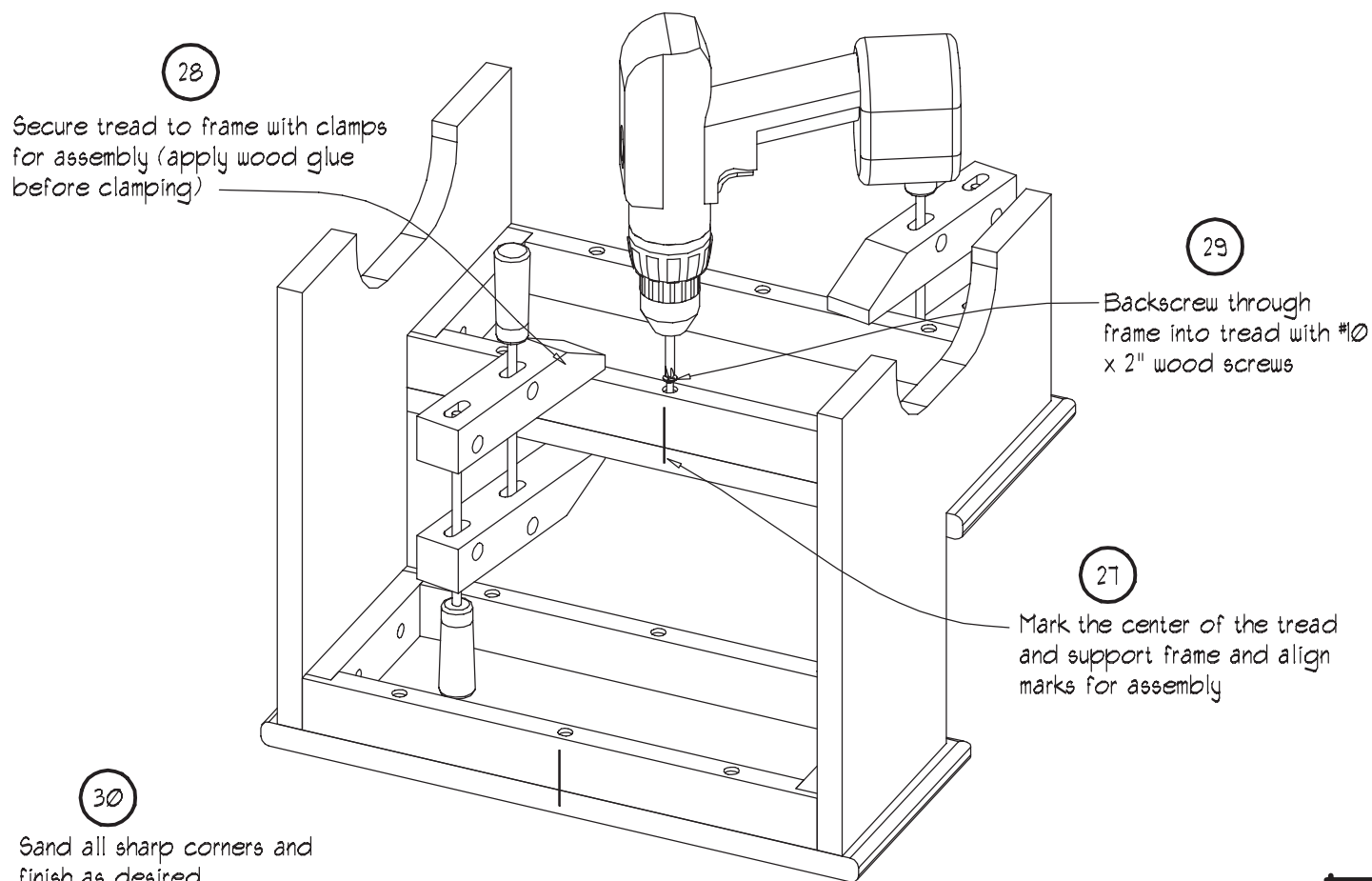

28

Secure tread to frame with clamps for assembly (apply wood glue before clamping)

29

Backscrew through frame into tread with #10 x 2" wood screws

27

Mark the center of the tread and support frame and align marks for assembly

30

Sand all sharp corners and finish as desired.

