



Wow! I Made It.com

## Wastebasket

*Here's an easy (and handsome) alternative to those unattractive plastic wastebaskets. It can be built from just a few feet of pine, rope molding, and some drawer pulls. Paint and a little imagination will transform the wastebasket into a one-of-a-kind decorative accent.*



## **Materials List**

- 6 linear feet of 1 x 12 pine
- 5 linear feet of ¾" wide rope molding
- 4 1-1/2"-diameter round drawer pulls

## **Hardware**

- 30, 1-1/2" 4d finishing nails
- 20, 1" 2d finishing nails

## **Special Tools and Techniques**

- Miter

## **Cutting List**

Code	Description	Qty.	Material	Dimensions
A	Sides	4	1 x 12 pine	14" long
B	Bottom	1	1 x 12 pine	9-3/4" long
C	Long trims	2	¾" wide rope molding	12-3/4" long
D	Short trims	2	¾" wide rope molding	11-1/4" long

## ***Constructing the Wastebasket***

1. Cut four Sides (A) from 1 x 12 pine, each measuring 14 inches.
2. Place two Sides (A) on a level surface, parallel to each other and 9-3/4 inches apart. Apply glue to the meeting surfaces, and place a third Side (A) over the edges of the first two Sides (A), as shown in *Figure 1*. Nail through the third Side (A) into the edges of the first two Sides (A). Use four 1-1/2" 4d finishing nails evenly spaced along each joint.
3. Turn the assembly upside-down, and repeat Step 2 to attach the fourth side (A) to the assembly.
4. Cut one Bottom (B) from 1 x 12 pine measuring 9-3/4 inches.
5. Fit the Bottom (B) inside the assembled Sides (A), flush with the ends of the Sides (A), as shown in *Figure 2*. Apply glue to the meeting surfaces, and nail through the face of the

fours sides (A) into the edge of the Bottom (B) using 1-1/2" 4d finishing nails on each side (A).

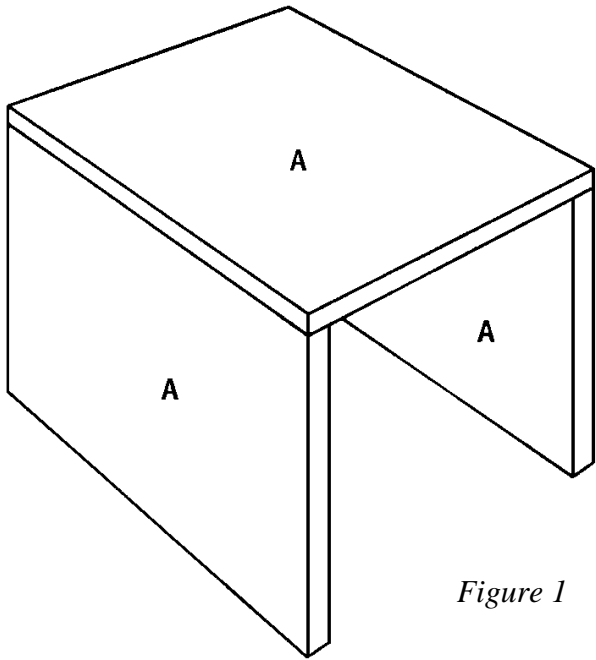

Figure 1

### **Adding the Top Trim**

1. Cut two Long Trims (C) from  $\frac{3}{4}$ " wide rope molding, each measuring 12-3/4-inches. Miter each end at opposing 45-degree angles, as shown in *Figure 3*.
2. Place the Sides/Bottom assembly so that the Bottom (B) is down on the working surface. Place the Long Trims (C) on the 12-3/4-inch top edge of the Sides (A), as shown in *Figure 3*. Apply glue to the meeting surfaces and nail through the Long Trims (C) into the edge of the Sides (A) using four 1" finishing nails.

3. Cut two Short Trims (D) from  $\frac{3}{4}$ " wide rope molding, each measuring 11-1/4-inches. Miter each end at opposing 45-degree angles.
4. Place the Short Trims (D) on the 11-1/4-inch top edge of the sides (A), as shown in *Figure 3*.
5. Apply glue to the meeting surfaces, and nail through the Short Trims (D) into the edge of the Sides (A) using four 1" finishing nails.

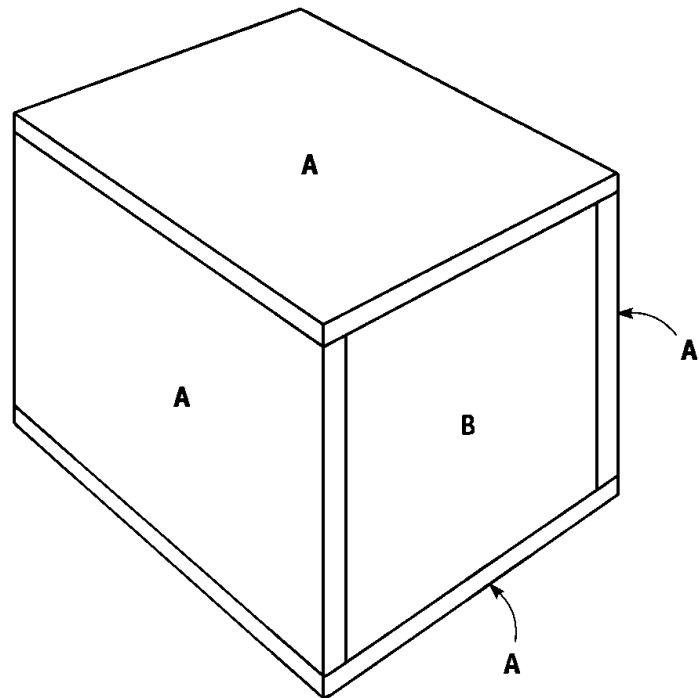

Figure 2

### **Adding the Feet**

1. Place the assembled Sides/Bottom upside-down so that the trims are on the working surface.

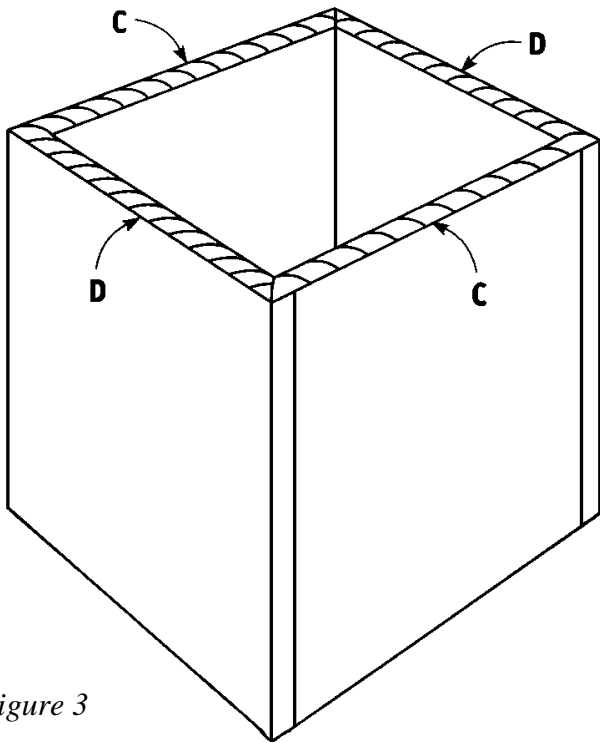

Figure 3

honey maple stain. We purchased a decorative stamp and gold paint, and stamped random designs over the stained wastebasket.

- Using *Figure 4* as a guide, mark the holes for the foot screws. Drill holes large enough to accommodate the drawer pull screw through the Bottom (B). Place the screws through the drilled holes from inside the assembly bottom (B) and screw them onto the round drawer pulls.

### **Finishing the Wastebasket**

- Fill any holes, cracks or crevices with wood filler.
- Thoroughly sand all areas of the completed wastebasket.
- Paint or stain the wastebasket with the color of your choice. We chose a

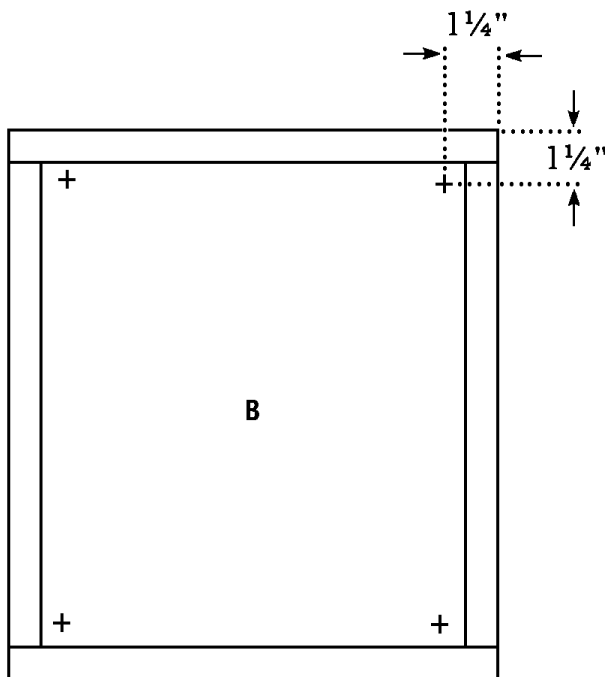

Figure 4





---

**Enjoy other indoor and outdoor furniture and accessories projects from !**

