



Garden Sofa

This sofa would be at home in a garden, on a patio, or on a boat dock. It is constructed of pressure-treated wood so it can withstand the weather. The slats on the seat make the sofa comfortable and assure that rain will not puddle on top of it.



Materials and Supplies

- 62 linear feet of 2 x 4 pine
- 20 linear feet of 1 x 4 pine
- 30 linear feet of 1 x 2 pine

Hardware

- 30 3-1/2" screws
- 30 2-1/2" screws
- 160 3d x 1-1/4" nails
- 60 4d x 1-1/2" nails

Special Tools and Techniques

- Dadoes
- Bar Clamps

Cutting List

Code	Description	Qty.	Materials	Dimensions
A	Horizontal Side	4	2 x 4 pine	15-1/2" long
B	Long Vertical Side	2	2 x 4 pine	35" long
C	Short Vertical Side	2	2 x 4 pine	29" long
D	Outer Seat Support	2	2 x 4 pine	59" long
E	Inner Seat Support	5	2 x 4 pine	19-1/2" long
F	Wide Slat	4	1 x 4 pine	59" long
G	Narrow Slat	2	1 x 2 pine	59" long
H	Horizontal Back	2	2 x 4 pine	59" long
I	Back Slat	20	1 x 2 pine	10" long

Constructing the Sofa Sides

1. Cut four horizontal sides (A) from 2 x 4 pine, each measuring 15-1/2 inches.
2. Cut two long vertical sides (B) from 2 x 4 pine, each measuring 35 inches.
3. Cut two short vertical sides (C) from 2 x 4 pine, each measuring 29 inches.
4. Place two horizontal sides (A) parallel to each other, and between one long vertical side (B) and one short vertical side (C), as shown in *Figure 1*. The top horizontal side (A) is exactly even with the end of the short vertical side (C) and the bottom horizontal side (A), and is 14 inches from the other end of that same vertical side (C), as shown in *Figure 1*. Toenail through the edges of the horizontal sides (A) into both the long and short vertical sides (B and C) using two 3-1/2" screws on each joint.

- Repeat Step 4 to assemble the second side.

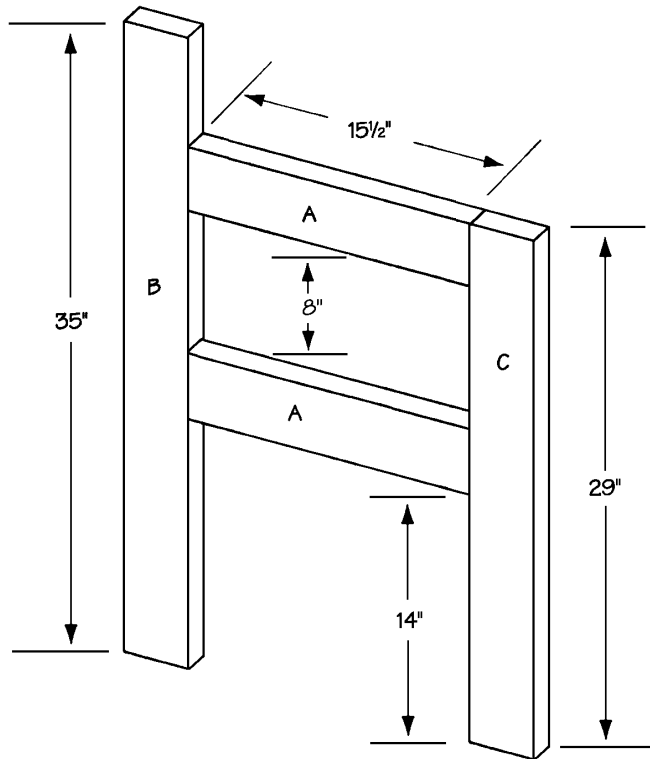

Figure 1

Adding the Seat

- Cut two outer seat supports (D) from 2 x 4 pine, each measuring 59 inches.
- For the next step, you may want to ask a willing helper to assist. If no one is available (or willing), use a bar clamp to hold the assembly while you screw it together. Place each side assembly on its long vertical edge (B), 59 inches away from the other side, as shown in *Figure 2*. Fit the front outer seat support (D) between the two short vertical sides (C), 14 inches from the upper edge of the sides. The top edge of the front outer seat support (D) should be exactly even with the top edge of the lower horizontal side (A). Screw through the side assemblies into the ends of the outer seat support (D), using two 2-1/2" screws on each joint.
- Repeat Step 7 to attach the other outer seat support (D) to the back of the sofa between the side assemblies, as shown in *Figure 2*. The top edge of the outer seat support (D) should be exactly even with the top edge of the lower horizontal sides (A). Using two 2-1/2-inch-long screws on each joint, screw through the long vertical sides (B) into the ends of the outer seat supports.
- Cut five inner seat supports (E) from 2 x 4 pine, each measuring 19-1/2 inches.
- Turn the assembly right side up. As shown in *Figure 3*, position one inner seat support (E) wide side up, between the two outer seat supports (D) and against one horizontal side (A), 3/4 inch below the top of the outer seat supports (D). Screw through the outer seat supports (D) into the end of the inner seat support (E), using two 2-1/2" screws.
- Repeat this step with another inner seat support (E) placed at the other end of the outer seat supports.

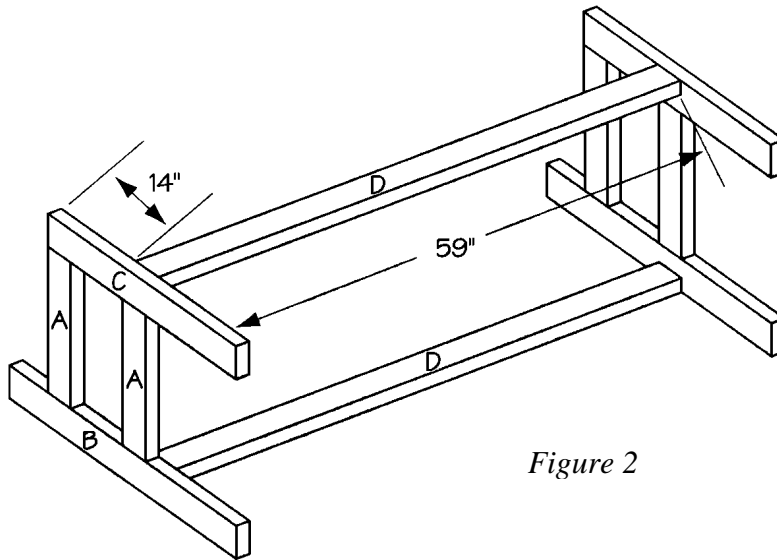

Figure 2

- Fit the remaining three inner seat supports (E) between the outer seat supports (D). Center one inner seat support (E), and space the other two evenly, as shown in *Figure 3*. Remember to place them $\frac{3}{4}$ " below the top of the outer seat supports (D). Screw through the outer seat supports (D) into the ends of the inner seat supports (E), using two 2-1/2" screws on each joint.

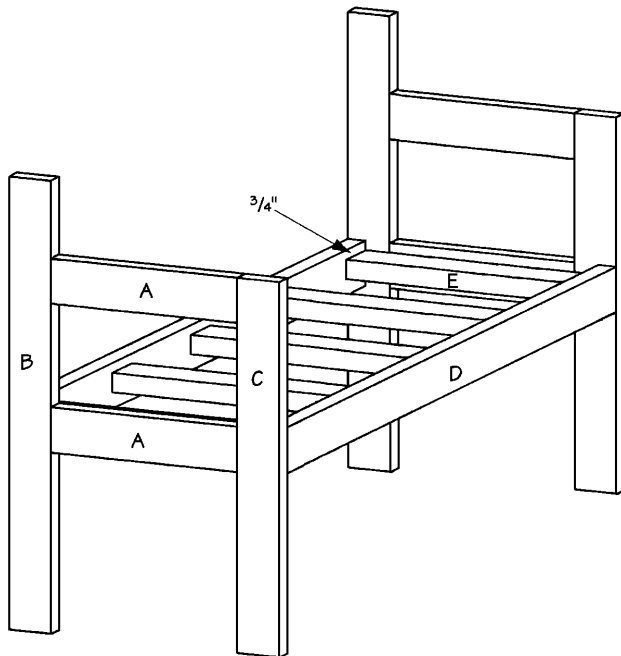

Figure 3

Adding the Seat Slats

- The sofa seat is comprised of two different widths of wood that are alternated. Cut four wide slats (F) from 1 x 4 pine, each measuring 59 inches.
- Cut two narrow slats (G) from 1 x 2 pine, each measuring 59 inches.
- Begin by placing a wide slat (F) over the seat supports (E) on the front of the sofa. Then place a narrow slat (G) next to it. Continue alternating the wide and narrow slats, ending with two wide slats (F) at the back of the sofa, as shown in *Figure 6*. Adjust the spacing so that the slats are approximately $\frac{3}{8}$ -inch apart. Nail through each of the slats (F and

G) into the seat supports (E), securing each of the slats to one of the seat supports (E). Use two 1-1/2"-long nails on each joint.

Constructing the Sofa Back

1. Cut two horizontal backs (H) from 2 x 4 pine, each measuring 59 inches.
2. Cut a 3/4" wide dado, 1/2" deep, down the length of one 59:" edge of each of the horizontal backs (H), as shown in *Figure 4*.

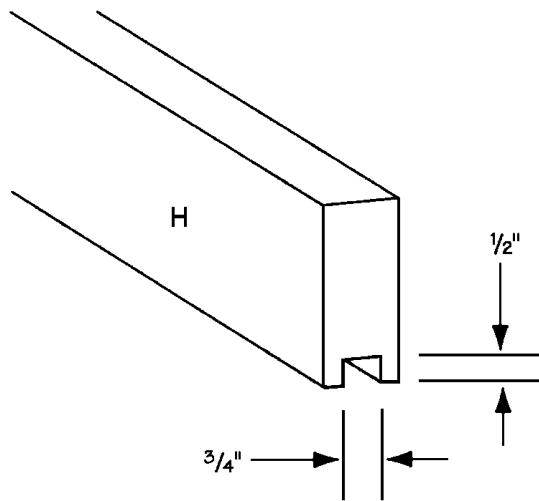

Figure 4

3. Cut 20 back slats (I) from 1 x 2 pine, each measuring 10 inches.
4. Working on a level surface, place the horizontal backs (H) parallel to each other, with the dados to the inside, as shown in *Figure 5*. Fit the ends of the 20 back slats (I) into the dados in each of the two horizontal backs (H). The spacing between the slats should be approximately 1-1/2". In fact, we used an extra slat as a spacer. When the back slats (I) are properly fitted into the dados, the distance between the two horizontal backs (H) should be 9 inches. The two outer back slats (I) should be even with the ends of the horizontal backs (H). When the position is perfect, the overall measurements of the back assembly should be 16" high and 59" wide. Secure the slats by nailing through the dadoed edge of the horizontal back (H) into the ends of the back slats (I), using two 1-1/4" nails on each joint.

5. Turn the assembly and repeat the nailing procedure on the other side.
6. It is now time to fit the back assembly between the two sides. To make the sofa more comfortable, the back assembly is tilted at an angle—out at the top and in at the bottom. The tilt angle is determined by the width of the 2 x 4 on the side assemblies. The lower edge of the back is fitted flush with the inside edge of the long vertical sides (B); the upper edge of the back is fitted flush with the outer edge of the long vertical sides (B), as shown in *Figure 6*. When you have the back fitted perfectly, secure the assembly with bar clamps. Screw through the long vertical sides (B) into the ends of the horizontal backs (H), using two 3-1/2" nails on each joint.

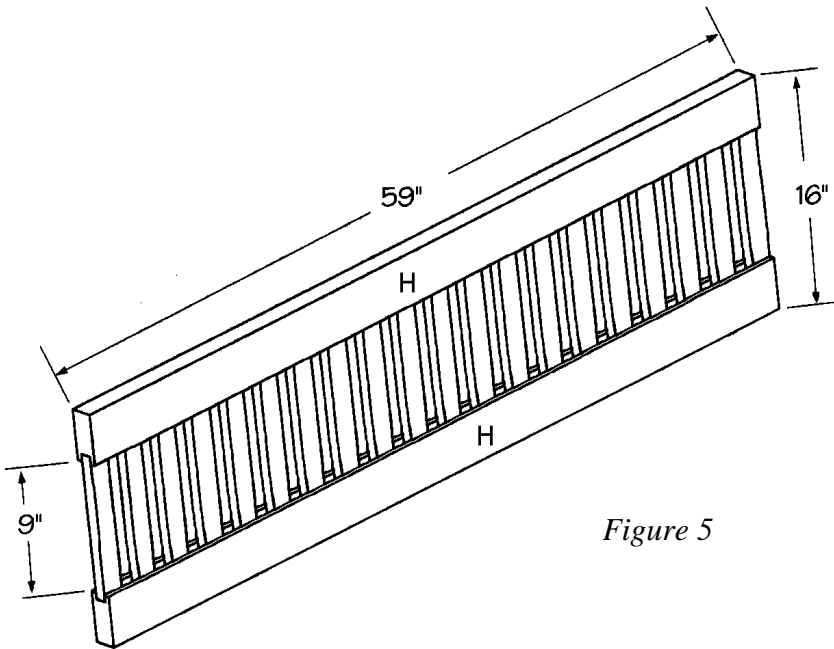

Figure 5

Finishing the Sofa

1. Fill any cracks, crevices, or screw holes with wood filler, and thoroughly sand all surfaces of the completed sofa.
2. Seal and paint or stain your sofa the color of your choice.

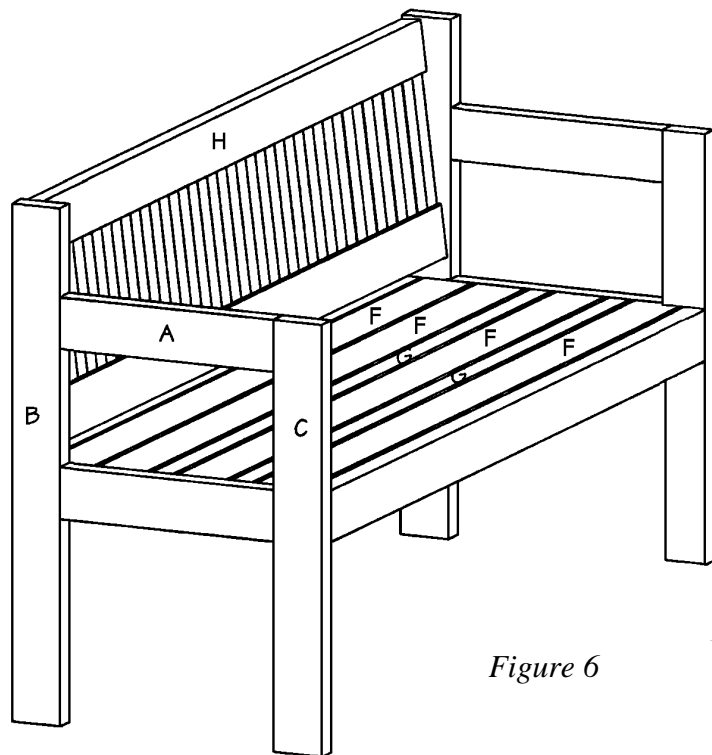

Figure 6