



Wow! I Made It.com

Desk

Our executive desk was built with specific needs in mind. We wanted a large desktop, large drawers, and a cubbyhole to house a rollaway hanging file cabinet. We are thrilled with our finished project. It's a beauty.



Materials

- 55 linear feet of 1 x 4 pine
- 2 linear feet of 1 x 8 pine
- 55 linear feet of 2 x 4 pine
- 2 sheets (4' x 8') 1/4" plywood
- 1/2 sheet (4' x 4") of 1/2" plywood
- 1 piece of 3/4" plywood, 24-3/4" x 72"

Hardware

- 3/4" wire brads
- 1 1/2" (3d) finishing nails
- 1-1/2" (4d) finishing nails
- 2-1/2" (8d) finishing nails
- 1" wood screws

- 1-1/2" wood screws
- 2" wood screws
- 2-1/2" wood screws
- 21-inch-long drawer glides
- Cabinet hinges
- Drawer pulls
- Magnetic catch

Special Tools and Techniques

- Chisel
- Long pipe clamps
- Mitters
- Router with 1/2" rabbet cutter
- Rabbets
- Dadoes

Cutting List

Code	Description	Qty	Materials	Dimensions
A	Short Frame	8	2 x 4 pine	23-1/4" long
B	Long Frame	8	2 x 4 pine	28" long
C	Side	4	1/4" plywood	24-1/4" x 28"
D	Back Frame	4	1 x 4 pine	23" long
E	Back	2	1/4" plywood	23" x 28"
F	Drawer Support	6	2 x 4 pine, ripped	23-1/4" long
G	Horizontal Support	4	2 x 4 pine	20" long
H	Vertical Trim	4	1 x 4 pine	28" long
I	Horizontal Trim	4	1 x 4 pine	16-1/2" long
J	Upper Drawer Front/Back	2	1/2" plywood	4-1/2" x 15-1/2"
K	Upper Drawer Side	2	1/2" plywood	4-1/2" x 23"
L	Drawer Bottom	2	1/4" plywood	14-7/8" x 23-3/8"
M	Lower Drawer Front/Back	2	1/2" plywood	10" x 15-1/2"
N	Lower Drawer Side	2	1/2" plywood	10" x 23"
O	Upper Drawer Front	1	1 x 8 pine	18-1/2" long

P	Vertical Drawer Frame	2	1 x 4 pine	13" long
Q	Horizontal Drawer Frame	2	1 x 4 pine	11-1/2" long
R	Center Drawer Front	1	1/4" plywood	7" x 12-1/2"
S	Vertical Door Frame	2	1 x 4 pine	25" long
T	Horizontal Door Frame	2	1 x 4 pine	11-1/2" long
U	Center Door Front	1	1/4" plywood	12-1/2" x 19"
V	Long Top Trim	2	1 x 4 pine	79" long
W	Short Top Trim	2	1 x 4 pine	31-3/4" long
X	Desk Top	1	3/4" plywood	24-3/4" x 72"

Building the Desk Bases

1. Cut eight short frames (A) from 2 x 4 pine, each measuring 23-1/4 inches long.
2. Miter the ends of each of the eight short frames at opposing 45-degree angles, as shown in *Figure 1*.

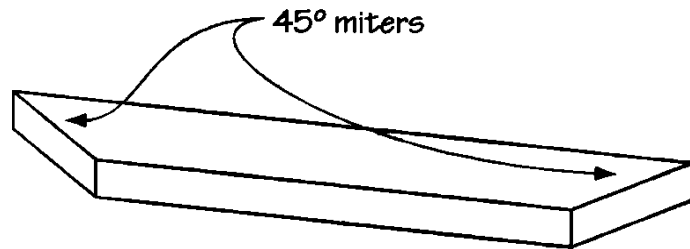

Figure 1

3. Cut eight long frames (B) from 2 x 4 pine, each measuring 28 inches long.
4. Miter the ends of each of the eight long frames (B) at opposing 45-degree angles, as shown in *Figure 1*.
5. Cut four sides (C) from 1/4-inch plywood, each measuring 24-1/4" x 28".
6. Place two long frames (B) on a level surface, parallel to each other and 21 inches apart, as shown in *Figure 2*. Place two short frames (A) between the ends of the long frames (B), matching miters, to form a 23-1/4 x 28-inch rectangle. Apply glue to the meeting surfaces and nail one side (C) over the four frames (A and B), as shown in *Figure 3*. Note that one 28-inch edge of the side (C) extends 1 inch past the frame assembly. Use 1-1/4-inch (3d) finishing nails spaced every four inches.
7. Repeat Step 6 three more times to assemble three additional frame assemblies, using the

remaining six short frames (A), six long frames (B) and three sides (C).

8. Cut four back frames (D) from 1 x 4 pine, each measuring 23 inches long.
9. Place two frame assemblies on a level surface, parallel to each other, and 21-1/2 inches apart. The 1-inch-wide side extensions should be placed on top and to the outside. Fit two back frames (D) between the two sides (C) over the long frames (B), as shown in Figure 4. Apply glue to the meeting surfaces and screw through the back frames (D) into the edges of the long frames (B). Use two 1-1/2-inch screws on each joint.

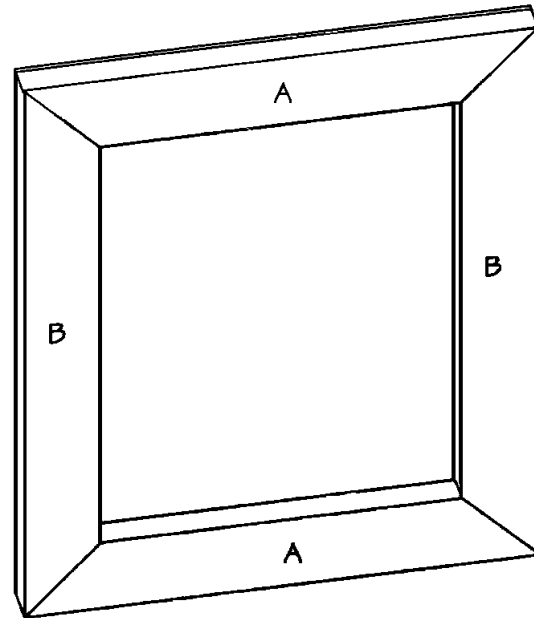

Figure 2

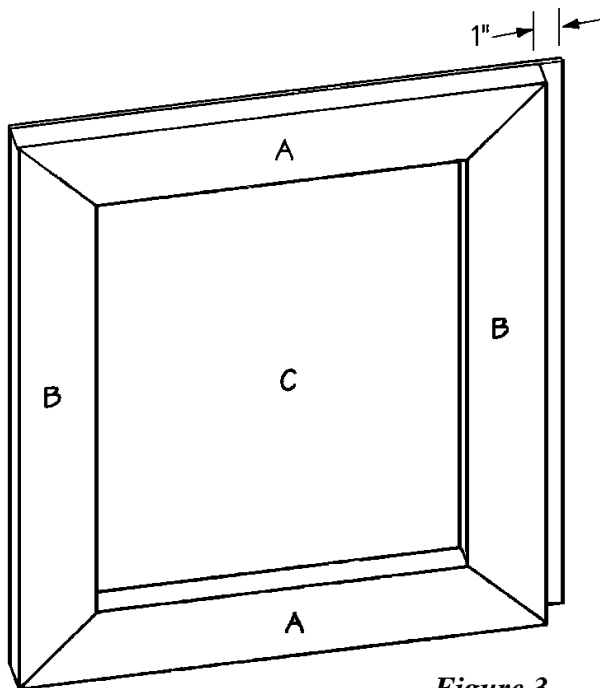

Figure 3

10. Repeat Step 9 to attach the remaining two back frames (D) to the remaining two frame assemblies.
11. Cut two backs (E) from 1/4-inch plywood, each measuring 23 x 28 inches.
12. Apply glue to the meeting surfaces and place one back (E) over the two back frames (D), as shown in Figure 5. Nail through the back (E) into both back frames (D). Use five evenly spaced 3/4-inch brads on each edge of each back frame (D).

13. Repeat Step 12 to attach the remaining back (E) to the remaining base assembly.

Completing the Drawer Base Assembly

1. As the photograph shows, the desk has two bases. The left base consists of two drawers and the right base has just one hinged cabinet door. This section covers the completion of

the left drawer base assembly. However, some of the pieces used in the drawer base are also used in the cabinet base. Remaining pieces cut but not used in this section should be labeled and set aside for use in completing the cabinet base.

- Rip a total of 12 linear feet of 2 x 4 pine to a width of 1-3/4 inches.

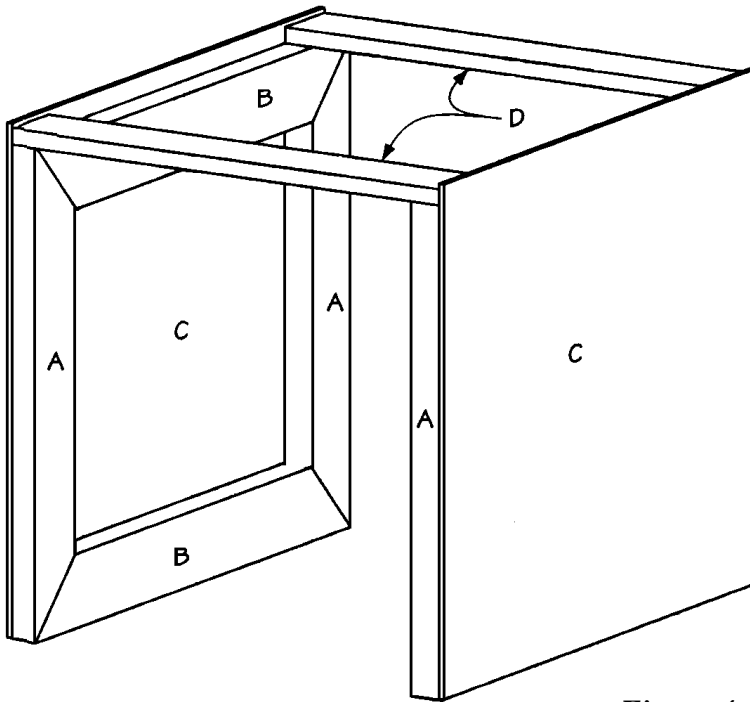

Figure 4

- Cut six drawer supports (F) from the ripped 2 x 4 pine, each measuring 23-1/4 inches long.
- Apply glue to the meeting surfaces and attach one drawer support (F) to the left side of one base assembly, 8 inches from the top of the base assembly, as shown in *Figure 6*. Make sure that the 1 3/4-inch dimension is horizontal. Screw through the drawer support (F) into the

two long frames (B). Use two 2-1/2-inch screws on each joint.

- Repeat step 16 to install the second drawer support (F) opposite the first, on the right side of the base assembly.
- Repeat steps 15 and 16 to attach the remaining two drawer supports (F) 3-1/2 inches from the bottom of the base assembly.
- Install the purchased drawer glides on the inside edges of each of the drawer supports (F), following the manufacturer's directions. The drawer glides we purchased took up 1/2-inch of horizontal space on each side. If your glides are not the same measurement, you will need to alter the horizontal dimensions of the drawer to accommodate the difference.
- Cut four horizontal supports (G) from 2 x 4 pine, measuring 20 inches long.
- Attach one horizontal support (G) at the top front of the base assembly between the two support frames, as shown in *Figure 6*. Nail through the sides (C) into the end of the

horizontal support (G), using two 2-1/2" (8d) finishing nails on each joint.

Figure 5

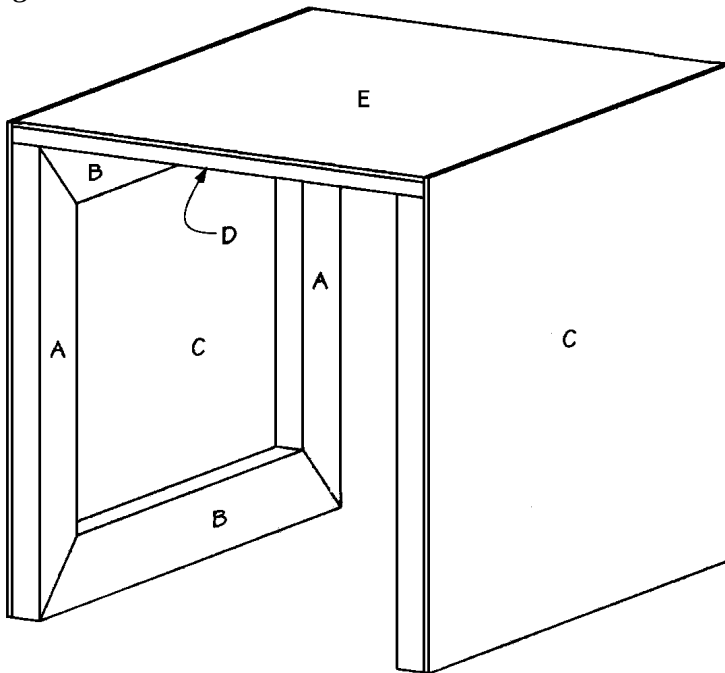

(G) into the horizontal supports (G) and the frame support, using 1-1/2" (4d) finishing nails spaced every 5 inches.

10. Repeat Step 9 two times to attach a second horizontal support (G) just below the upper two drawer supports (F), and just below the lower drawer supports (F).
11. Cut four vertical trims (H) from 1 x 4 pine, each measuring 28 inches long.
12. Apply glue to the meeting surfaces and attach one vertical trim (G) to the left front of the base assembly, as shown in *Figure 7*. Nail through the vertical trim

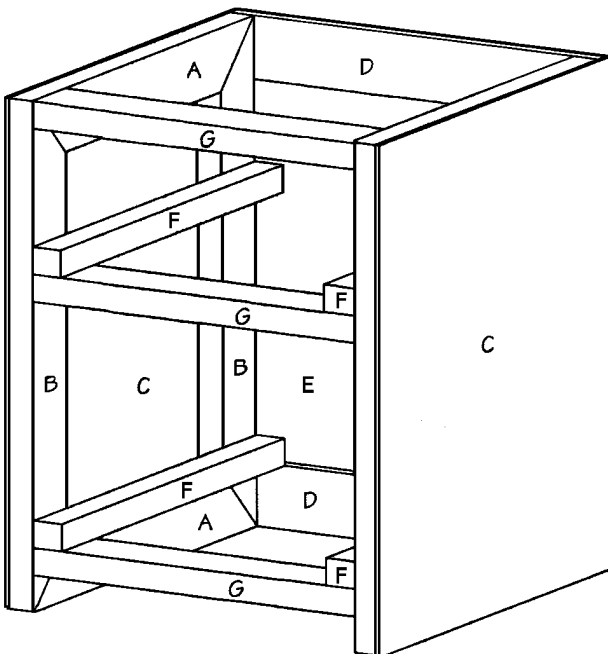

13. Repeat Step 12 to attach a second vertical trim (H) on the right front of the base assembly.
14. Cut four horizontal trims (I) from 1 x 4 pine, each measuring 16-1/2 inches long.
15. Attach one horizontal trim (I) at the top front of the base assembly between the two vertical trims (H), as shown in *Figure 7*. Apply glue to the meeting surfaces and nail through the horizontal trim (I) into the horizontal supports (G), using three evenly spaced 1-1/2-inch (4d) finishing nails.

Figure 6

- Repeat Step 15 to attach two more horizontal trims (I) between the two vertical trims (H) flush with the tops of the remaining horizontal supports (G), as shown in *Figure 7*.

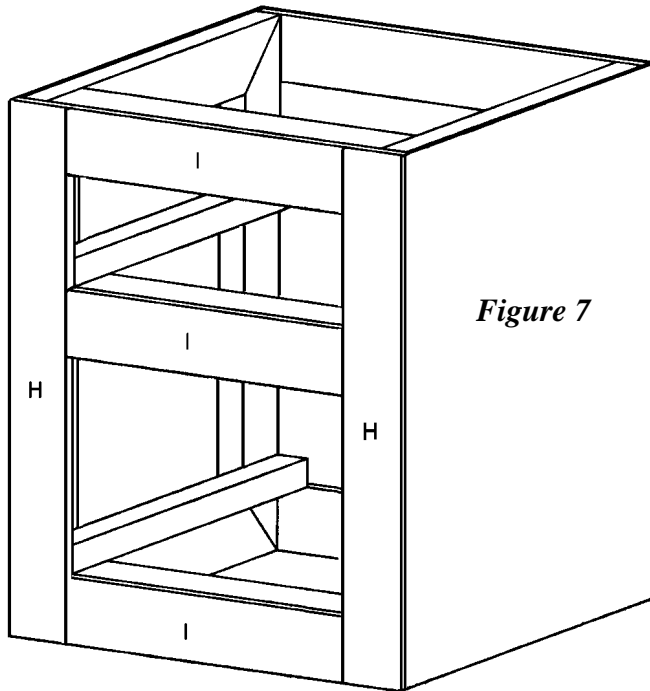

Making the Upper Drawer

- There are two drawers in this desk. Both are constructed as shown in the assembly diagram in *Figure 8*. The only difference is the size of the drawer pieces.
- Cut two upper drawer front/back pieces (J) from 1/2-inch plywood, each measuring 4- 1/2 x 15-1/2 inches.
- Cut two upper drawer sides (K) from 1/2-inch plywood, each measuring 4-1/2 x 23 inches.
- Cut a 1/4" x 1/4" dado on the inside of each upper drawer piece (J and K) 3/8-inch from the lower edge, to accommodate the plywood bottom.
- Cut two drawer bottoms (L) from 1/4-inch plywood, measuring 14-7/8 x 23-7/8 inches.
- Assemble the upper drawer as shown in *Figure 8*. Note that the upper drawer front/back pieces (J) overlap the ends of the upper drawer sides (K). Use three 1-1/2" (4d) finishing nails on each end of the overlapping boards. The drawer front will be added later.
- Cut two lower drawer front/back pieces (M) from 1/2-inch plywood, each measuring 10 x 15-1/2 inches.
- 35 Cut two lower drawer sides (N) from 1/2-inch plywood, each measuring 10 x 23 inches.
- Cut a 1/4" x 1/4" dado on the inside of each lower drawer piece (M and N) 3/8-inch from the lower edge, to accommodate the plywood bottom.
- Repeat the drawer assembly in Step 6 using the remaining drawer bottom (L), the lower drawer fronts (M), and the lower drawer sides (N).
- Attach the upper and lower drawers to the drawer glides, following the manufacturer's instructions.

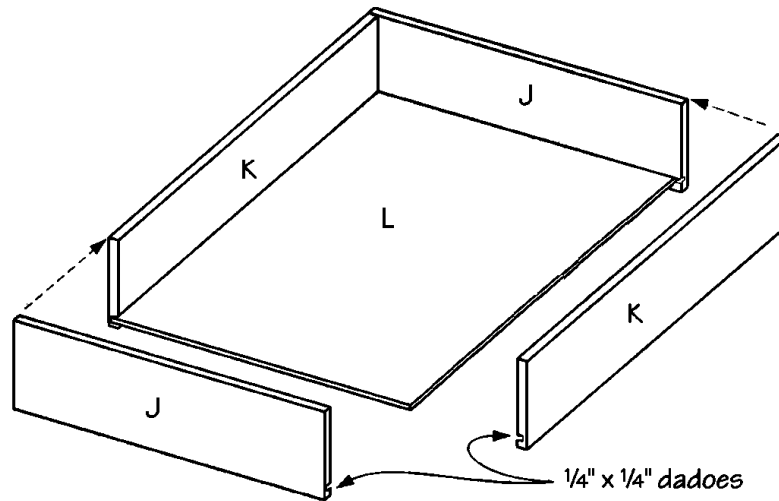

Figure 8

Making the Drawer Fronts

1. Cut one upper drawer front (O) from 1 x 8 pine, measuring 18-1/2 inches long.
2. The lower drawer front consists of 1/4-inch plywood framed with 1 x 4 pine. Cut two vertical drawer frames (P) from 1 x 4 pine, each measuring 13 inches long.
3. Cut two horizontal drawer frames (Q) from 1 x 4 pine, each measuring 11-1/2 inches long.
4. Place the two vertical drawer frames (P) on a level surface, parallel to each other and 11-1/2 inches apart. Fit the two horizontal drawer frames (Q) between the ends of the two vertical drawer frames, as shown in *Figure 9*. Apply glue to the meeting surfaces and clamp the assembly for a few hours.
5. To temporarily reinforce the joints for the next step, use a staple gun to staple three times over each joint. Then rout the inside edges of the assembled drawer front frame, 1/4-inch deep and 1/2-inch wide. Square the corners with a chisel. Remove the staples.
6. Cut one center drawer front (R) from 1/4-inch plywood, measuring 7 x 12-1/2 inches.
7. Apply glue to the meeting surfaces and fit the center drawer front (R) into the routed edges of the assembled drawer front frame. Nail through the center drawer front (R) into the routed edges of the vertical drawer frames (P) and the horizontal drawer frames (Q). Use 3/4-inch brads driven at an angle and spaced every 4 inches.
8. To attach the drawer fronts to the assembled drawers, place a piece of wood between the back of each drawer and the back of the desk assembly so that the drawers are held flush with the front of the desk. Use heavy-duty double-sided tape to hold both drawer fronts

temporarily in place until you have both drawer fronts positioned exactly right. The drawer fronts should be centered over the openings in the front of the drawer base. Then attach the fronts to the drawers. Use 1-inch screws to screw through the drawer into the drawer front on the upper drawer and into the drawer frame on the lower drawer. Use four screws on the upper drawer and eight screws on the lower one.

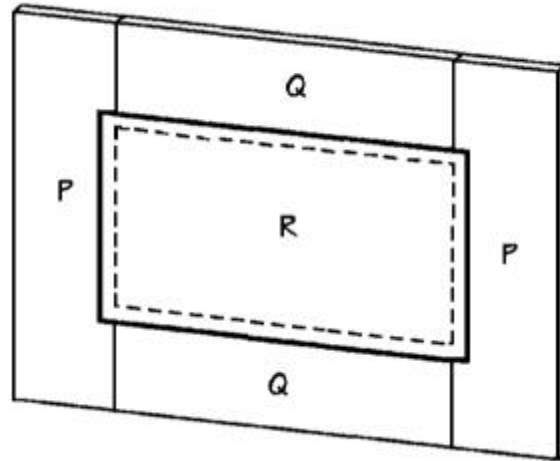

Figure 9

Completing the Cabinet Door Base Assembly

1. Attach the remaining horizontal support (G) at the top front of the remaining base assembly between the two support frames, as shown in *Figure 6*. Nail through the sides (C) into the end of the horizontal support (G), using two 2-1/2-inch nails on each joint.
2. Apply glue to the meeting surfaces and attach one drawer support (F) to the left side of the base assembly, flush with the bottom of the base assembly. Screw through the drawer support (F) into the two long frames (B) and the lower short frame (A). Use five 2-1/2-inch screws evenly spaced.
3. Repeat Step 2 to attach the remaining lower drawer support (F) to the opposite side of the base assembly.
4. Apply glue to the meeting surfaces and attach one vertical trim (H) to the left front of the base assembly, as shown in *Figure 7*. Nail through the vertical trim (H) into the horizontal support (G), the frame support, and the drawer support (F). Use 1-1/2-inch (4d) finishing nails spaced every 5 inches.
5. Repeat Step 50 to attach the remaining vertical trim (H) on the right front of the base assembly.
6. Attach the remaining horizontal trim (I) to the top front of the base assembly between the

two vertical trims (H), as shown in *Figure 7*. Apply glue to the meeting surfaces and nail through the horizontal trim (I) into the horizontal support (G). Use 3 evenly spaced 1-1/2" (4d) finishing nails.

Making the Door

1. The door consists of 1/4-inch plywood framed with 1 x 4 pine. Cut two vertical door frames (S) from 1 x 4 pine, each measuring 25 inches long.
2. Cut two horizontal door frames (T) from 1 x 4 pine, each measuring 11-1/2 inches long.
3. Place the two vertical door frames (S) on a level surface, parallel to each other and 11-1/2 inches apart. Fit the two horizontal door frames (T) between the ends of the two vertical door frames, as shown in *Figure 9*. Apply glue to the meeting surfaces and clamp the assembly overnight.
4. To temporarily reinforce the joints for the next step, use a staple gun to staple three times over each joint. Then rout the inside edges of the assembled door front frame, 1/4-inch deep and 1/2-inch wide. Use a chisel to square the corners and remove the staples.
5. Cut one center door front (U) from 1/4-inch plywood, measuring 12-1/2 x 19 inches.
6. Apply glue to the meeting surfaces and fit the center door front (U) into the routed edges of the assembled door front frame. Nail through the center door front (U) into the routed edges of the vertical door frames (S) and the horizontal door frames (T). Use 3/4-inch brads driven at an angle and spaced every four inches.
7. Attach the door to the base assembly using two cabinet hinges. The door should be hung 1/4-inch from the bottom of the base assembly and centered horizontally.

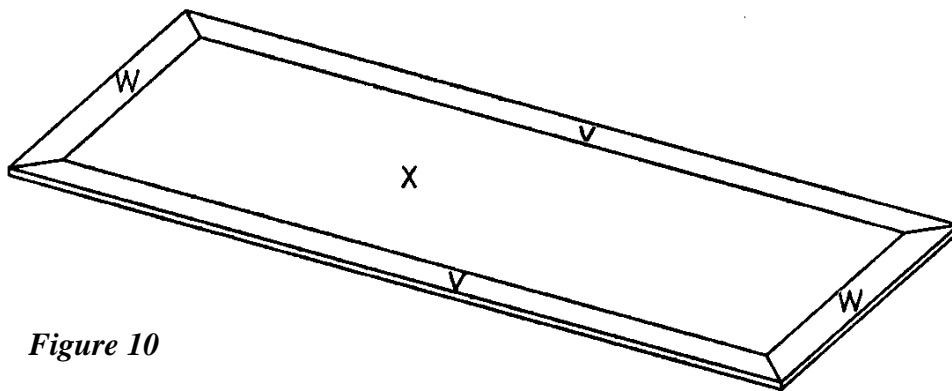

Figure 10

Making the Desktop

1. Cut two long top trims (V) from 1 x 4 pine, each measuring 79 inches long.

2. Miter both ends of each long top trim (V) at opposing 45-degree angles, as shown in *Figure 1*.
3. Cut two short top trims (W) from 1 x 4 pine, each measuring 31-3/4 inches long.
4. Miter both ends of each short top trim (W) at opposing 45-degree angles, as shown in *Figure 1*.
5. Cut one desk top (X) from 3/4-inch plywood, measuring 24-3/4 x 72 inches.
6. Place the desktop (X) on a level surface. Position the long and short top trims (V and W) along the outer edges of the desktop (X), as shown in *Figure 10*. Apply glue to the meeting edges, and clamp the five pieces of wood together with pipe clamps for a few hours. The result is a desktop that now measures 31-3/4 x 79 inches.
7. Place the two base assemblies on a level surface, parallel to each other and 24-1/2 inches apart. Center the desktop over the two base assemblies. Attach the three pieces together by screwing through the top horizontal supports (G) into the desktop. Use three 2-inch screws on each joint. Do not use glue, as you would be unable to disassemble the desk for moving.

Finishing

1. Fill any screw holes or imperfections in the wood with wood filler.
2. Thoroughly sand all of the wood parts on the completed desk.
3. Stain or paint the desk the color of your choice. We chose a whitewash stain for our desk.
4. Install the three drawer pulls on the two drawers and the door. Also install a magnetic catch on the door.

Try other projects from

!



Living & Dining Rooms



Kitchen

Face facts! If you're preparing food while guests or family are in the house, chances are good that you'll have an audience. Because we enjoy relaxed entertaining, and especially kitchen company, our kitchen hutch, island and telephone table are designed to serve as coordinated pieces. (The island and telephone table also serve as "people perches.") A plate of appetizers on the island and self-serve beverages on the telephone table make everyone feel at home while we finish preparing the meal.

