

Project 15613EZ: Butler's Tray Table



A butler's tray table is truly a classic piece of furniture. Because it can be used with many styles of furniture, it has become very popular in recent years. But, like many other styles that are copied for hundreds of years, some of the butler's tray tables made today are very different from the original article. I wanted to build a butler's tray table for my living room, so I began searching for a specimen that I liked so I could copy it. Most of what I found was too large, or too massive-looking to suit my needs. In fact, most of the tops were so big I couldn't imagine the size of the butler it would take to carry one of them.

But then I discovered an antique in a home in Abingdon, Virginia that was exactly what I wanted. According to the owner, it was well over 100 years old. The top was completely original. However, the original folding base had been lost years ago, so the owner had commissioned a local craftsman to make a replacement. The original base held the top about waist high, a convenient service height for the butler. The replacement base holds the top at coffee table height.

Butler's Tray Table Complete Schematic

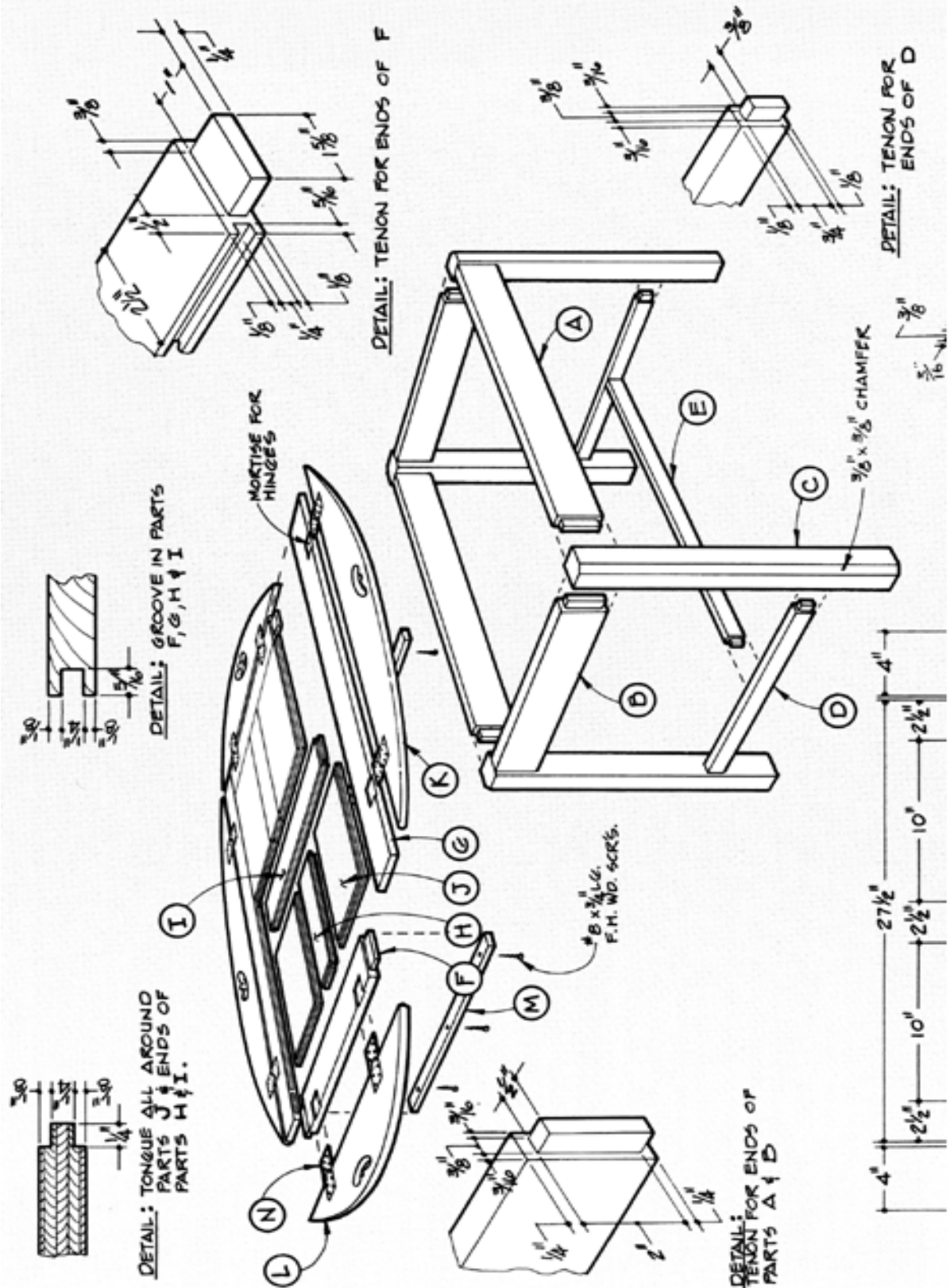

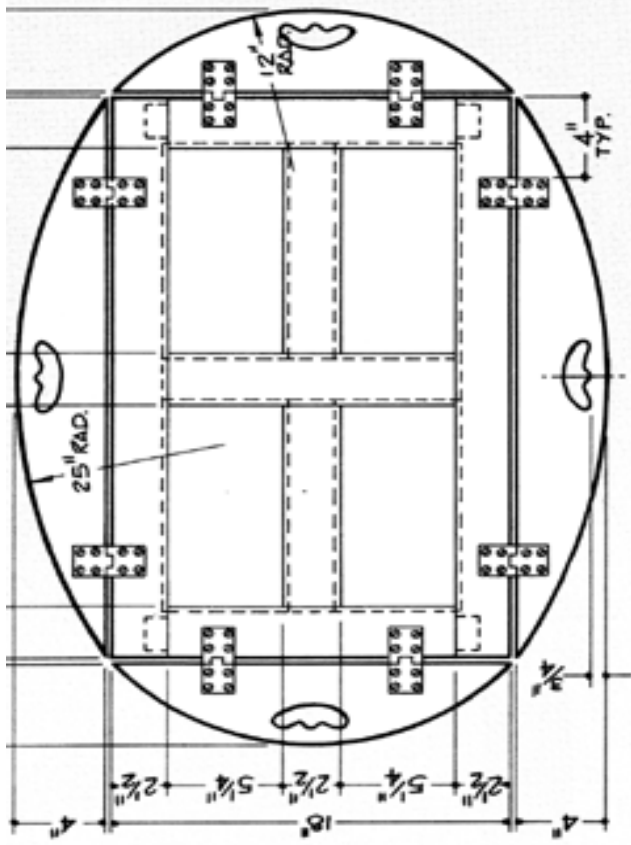

TOP VIEW

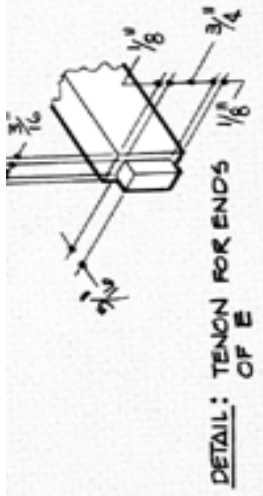

DETAIL: TENON FOR ENDS OF E

HANDLE CUTOUT TEMPLATE

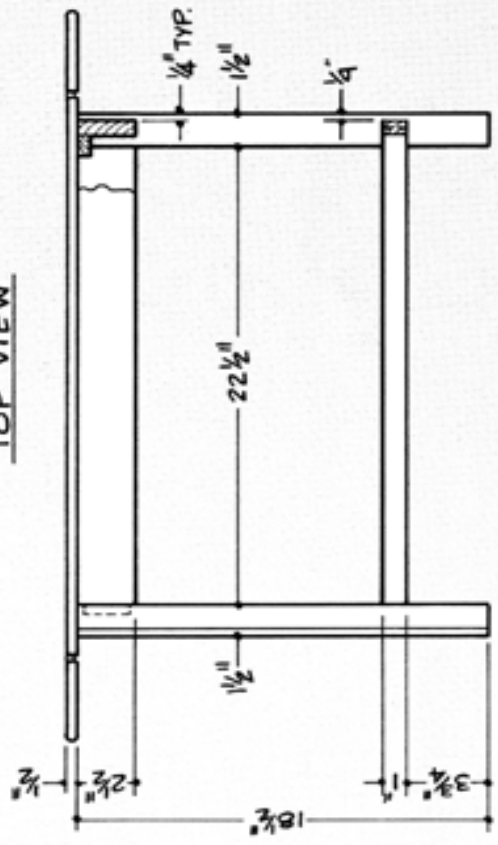
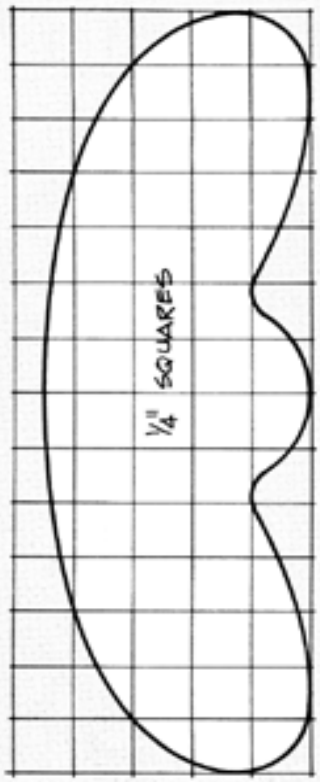

FRONT ELEVATION

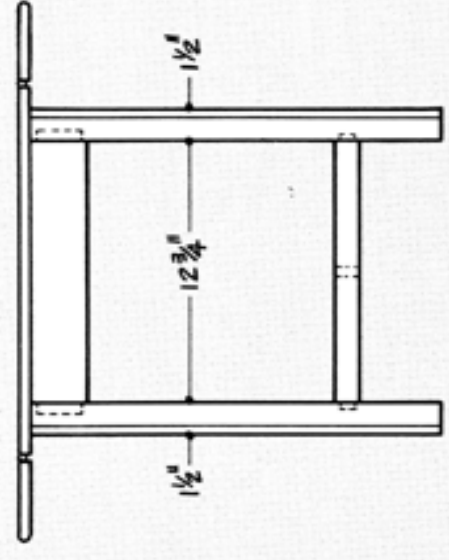

SIDE ELEVATION

Butler's Tray Table Materials List

Part	Description	Size	No. Req'd
A	Front and Back Apron	3/4" x 2-1/2" x 23-1/2"	2"
B	End Aprons	3/4" x 2-1/2" x 13-3/4"	2
C	Legs	1-1/2" x 1-1/2" x 18-1/2"	4
D	Base Rail	3/4" x 1" x 13-1/2"	2
E	Stretcher	3/4" x 1" X 24-1/8"	1
F	Frame End	1/2" x 2-1/2" X 15"	2
G	Frame Front and Back	1/2" x 2-1/2" x 27-1/2"	2
H	Top Rail	1/2" x 2-1/2" x 10-1/2"	2
I	Stile	1/2" x 2-1/2" X 13-1/2"	1
J	Panel	1/2" x 5-3/4" x 10-1/2"	4
K	Front and Back Leaf	1/2" x 4" x 27-1/2"	2
L	End Leaf	1/2" x 4" x 18"	2
M	Cleat	1/2" x 1" x 12-11/16"	2
N	Hinge	As desired.	8

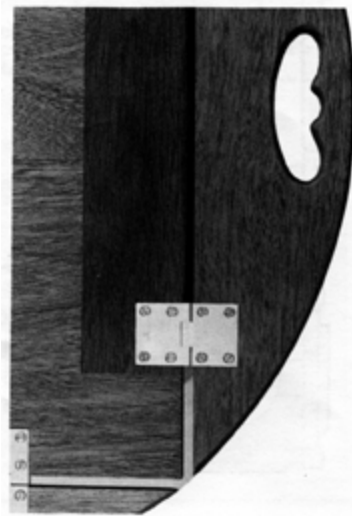

Butler's Tray Table Step-by-Step Instructions

1. Obtain 1/2" mahogany stripe plywood to make the panels (J), as making them from solid stock could result in problems since they tend to shrink and swell with changes in humidity.
2. Obtain Honduras mahogany solid stock for all the other project parts.

3. Cut the panel (J) to 5-3/4" wide x 10-1/2" long.
4. Cut a 1/4" by 1/4" tongue around all four edges as shown in the materials list.
5. Cut the frame end (part F) to length and width.
6. Cut a 1/4" x 5/16" groove (see Detail) along the inside edge.
7. Cut a 1/4" x 1-5/8" tenon on each end.
8. Make the stopped groove along the inside edge of part G.
9. Make the mortise in the part F tenon. **NOTE: Make the mortise slightly more than 1" deep to allow for excess glue.**
10. Make the grooves along both edges and the 1/4" x 1/4" tongues on each end of Parts H and I.
11. Use glue and pipe clamps assemble the top as shown.
12. Check to make sure the top is flat before setting aside to dry overnight.
13. Cut parts K and L from the same 1/2" stock.
14. Trace handle-hole cuts from a cardboard template.
15. Use the jigsaw to cut the handle holes.
16. Equip your hand router with a 1/4" radius bit.
17. Round over the curved edges of parts K and I.
18. Round over the cutouts.
19. Obtain Butler's Tray hinges so that the flaps will lock in the up and down positions.
20. Use a router guided by a homemade template to make the recesses for the hinges in the top.
21. Use a sharp chisel to finish the corners of the hinge mortises.
22. Screw two strips of wood (part M) across the bottom of the top assembly. These serve to strengthen the top and to position it properly on its base.
23. Chamfer the outside edge of each leg.
24. Use mortise and tenon construction to make all joints.
25. Sand the machined edges by hand to give the base a finished appearance.
26. Finish as desired.
27. Complete by applying several coats of wax.