

# The Four Poster Bed



**Build this classic, Early-American style bed in any size -- from twin to King -- to suit your needs.**

If you've recently gone shopping for a top-quality four-poster bed, you've already discovered how expensive one of these "beauties" can be - especially if they're made of hard maple or cherry, like our example.

Here's your chance to save a bundle on the four-poster you've always wanted...and be sure it meets all your stringent quality requirements...because you crafted it with your own two hands.

The plans shown here are for a twin-sized bed, however, by simply enlarging the frame and headboard dimensions, you can make it any size you like...all the way up to King. You can even change the post profiles, if you like to make this bed truly your own.

## **Headboard and Frame**

**1:** Start by gluing-up the stock for your Headboard (A), according to the list of materials. Be sure to joint all edges first and use a sufficient number of bar clamps to achieve a tight fit of all mating boards. Wipe off any excess glue squeeze-out immediately with a damp cloth and allow the joined boards to dry for a full 24 hours before proceeding.

**2:** Enlarge the pattern shown in figure 1 onto an appropriately sized piece of cardboard or stiff paper. Scrape off any remaining wood glue that you may have missed on the surface of your stock. Cut your pattern out and trace it onto your glued-up Headboard blank.

**3:** Using your bandsaw or a hand-held saber saw, cut out the Headboard shape.

**4:** Use a Drum Sander to smooth all edges on the headboard. Shopsmith's special Oscillating Drum Sander will speed the process of achieving the super-smooth edges you need. Also, use a hand-held belt sander or pad sander to sand the front and back surfaces smooth.

**5:** Cut the Head and Foot Rails (B), Side Rails (C), Side Rail Cleats (D) and Slats (E) to size, according to the list of materials. **NOTE:** Remember that the sizes of these pieces will have to be altered if you're making a double, Queen or King-sized bed. If you're planning to make a Queen or King-sized bed, it would also be a good idea to make four or five slats, instead of the recommended three used in our twin-sized example.

**6:** Use your Dado set-up to cut the tenons on the ends of the Head and Foot Rails (B) (See Fig. 2), and Side Rails (C) (See Fig. 3).

**7:** Cut the 3/4" deep x 2-1/2" wide dados in the Side Rail Cleats (D) to hold the Slats (E) (See Fig. 4). Remember that if you're planning to build a double, Queen or King-sized bed, you'll need to create four or five dados in these Cleats instead of three.

**8:** Using your Drill Press with a 3/4" Brad Point Bit, bore a 1-3/8" deep stopped hole on each side of the Side Rail centerline, as shown in Fig 3. Use a hand chisel to join these two holes into an oval that will accept the nuts for the 6" long bolts that will anchor the Side Rails (C) to the posts (F) during assembly. **NOTE:** If you prefer, these recesses can also be created using a Hollow Chisel Mortising Package in lieu of drill bits and a hand chisel.

### **Posts**

**1:** Cut out and square the ten sections of turning stock that will be used for the Posts (F & G) and the Blanket Rail (H & I), according to the list of materials.

**2:** Locate the centers of the ends on all ten sections of turning stock. Using a straightedge, draw lines from corner-to-corner to find the exact centers.

**3:** Using pieces of fairly heavy cardboard stock, create the patterns for the Posts (F & G) and Blanket Rail (H & I), by following the pattern drawings, provided. If you're going to use Outside Calipers to control your cuts, you'll need to create the entire profile for each turning, as shown on the patterns. However, if you're planning to use the Shopsmith Lathe Duplicator to be sure all components match perfectly, you need only create half of each pattern. Then, you'll transfer that pattern to a piece of 1/8" to 1/4" thick hardboard to use as a template that you'll follow when turning your pieces. See your Duplicator Owner's Manual for valuable pattern-making tips. **NOTE:** Again, if you're making a double, Queen or King-sized Bed, the lengths of your Blanket Rail pieces (H & I) will have to be modified to fit the wider Bed Frame.

**4:** Turn the upper and lower sections of the Posts (F & G). **IMPORTANT:** Be sure not to turn the balls on the top section down so small that your workpiece will snap off during

turning. You can finish these balls a little later. Finish sand each section while its still mounted on the lathe.

**5:** Turn both sections of your Blanket Rail (H & I) (See Fig. 6). Finish sand each section while it's still mounted in the lathe.

**6:** To finish the balls on the tops of the Posts (G), cut off the waste stock. Round over the balls using a double-cut wood file, then sand them smooth.

**7:** Set up your MARK V for Horizontal Boring and drill the 1" diameter x 1-1/2" deep holes in the bottom sections of your Posts (F). These holes will accept the 1" diameter "tenons" you turned on the upper sections of the Posts. Tilt your MARK V Worktable to 45-degrees and use your Rip Fence to form a V-block for holding the Posts while you drill these holes. Bore a 1" diameter x 2-3/8" deep hole in the end of one of your Blanket Rail Spindle halves (See Fig. 6).

**8:** Assemble and glue all Post (F & G) and Blanket Rail (H & I) sections together and set aside to dry for 24 hours.

**9:** Label all Posts (HBR, HBL, FBL, FBR) to be sure you position the mortises in the proper locations during step 10, to follow.

**10:** Use a 7/8" Brad Point Bit or a Hollow Chisel Mortising set-up with a 1/2" Bit & Chisel set to create the Headboard and Foot Rail Post (F & G) mortises described here: a: 3-3/4" high x 7/8" wide x 9/16" deep mortises for the Side Rails (C) b: 3-3/4" high x 7/8" wide x 2-5/16" deep mortises for the Head & Foot Rails (B) c: 2" high x 3/4" wide mortises to the centerline of the Posts (F & G) for the Headboard (A)

**11:** Drill 1-1/8" diameter x 1" deep holes in the two Foot Rail Posts (F). These will accept the outer ends of the Blanket Rail

### **Assembly**

**1:** Using a portable drill, create 3/4" deep counterbores for the heads of your 3/8" x 6" assembly bolts in the bottoms (flat sections) of the Posts (F). Be sure these counterbores are a large enough diameter to accommodate the flat washers under the heads of your 6" long assembly bolts. Then, dry assemble the Head and Foot Rails (B) to the Posts (F). Use long bar or pipe clamps to hold the rails in position while you bore 3/8" diameter holes all the way through the four Posts (F) and the tenons in each end of the two Rails (B). (See Fig. 7)

**2:** Disassemble these components and use your Horizontal Boring set-up with a 3/8" diameter bit to bore 4-3/8" deep holes into the ends of the Side Rails (C). For proper positioning, see Figures 3 and 7. These four holes should break through one side of the mortises you created in the Side Rails (C) in step 8 under "Headboard and Frame" at the beginning of this article. During assembly, your bolts will go through the four Posts (F) and into the ends of the Side Rails (C). The mating nuts will be positioned within the

mortises and when the bolts are tightened, the Rails (C) will be drawn tightly into the Posts (F).

**3:** Glue the Side Rail Cleats (D) to the inside bottom of the Side Rails (C). For extra strength, add six 1-1/2" long #8 roundhead wood screws, spaced evenly along the length of each Cleat. (See Fig. 7)

**4:** Glue the Headboard (A) and Head Rail (B) to the Headboard Posts (F & G).

**5:** Glue the Blanket Rail (H & I) and the Foot Rail (B) to the Footboard Posts (F), (See Fig. 7)

**6:** Finish to suit your decor.

**7:** Attach the Side Rails (C) to the Headboard and Footboard assemblies with the 6" bolts and nuts. Drop the slats into the notches you formed in the Side Rail Cleats (D). (See Fig. 7) Cover the bolt heads with decorative hardware.

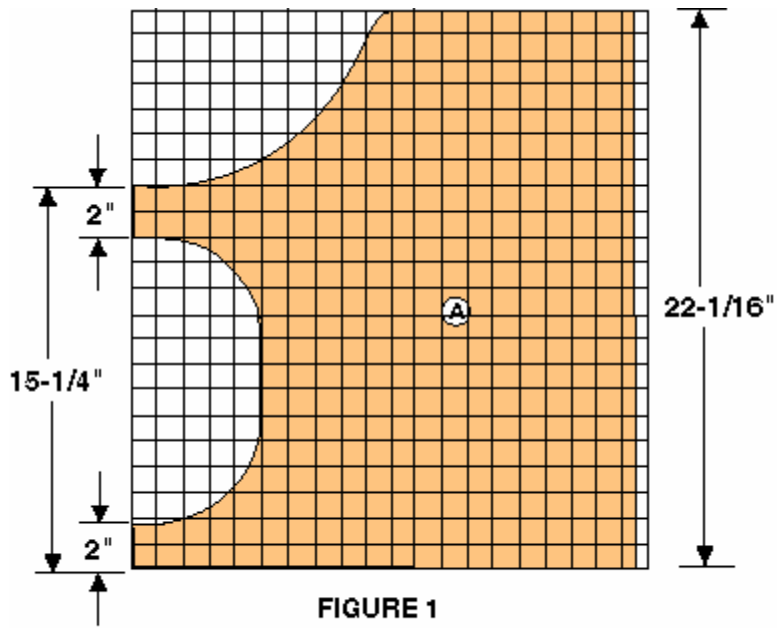

**FIGURE 1**  
**HEADBOARD**  
**1 SQUARE = 1 INCH**

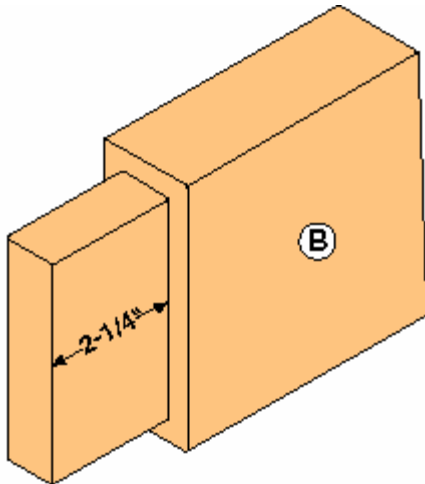

**FIGURE 2**  
**HEAD & FOOT**  
**RAIL TENONS**

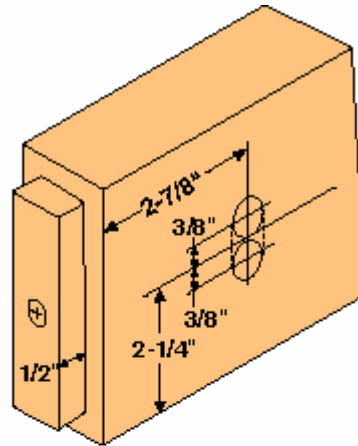

**FIGURE 3**  
**SIDE RAIL TENONS**

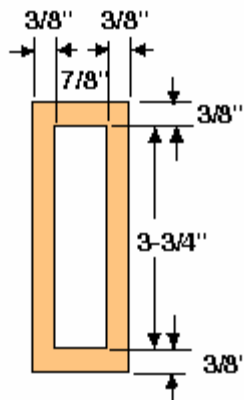

**SAME ON SIDE RAILS (C)**  
**AND HEAD AND FOOT RAILS (B)**

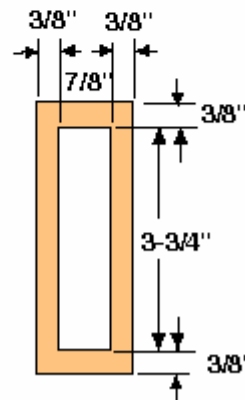

**SAME ON SIDE RAILS (C)**  
**AND HEAD AND FOOT RAILS (B)**

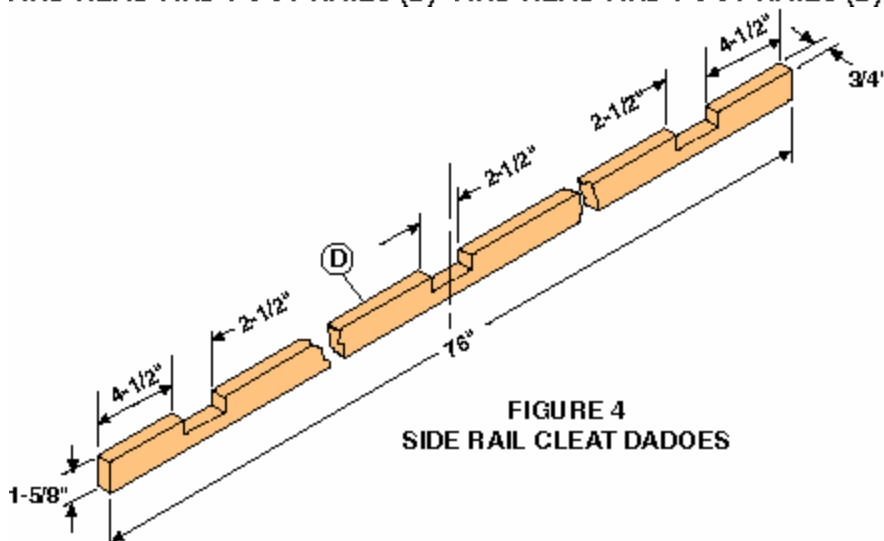

**FIGURE 4**  
**SIDE RAIL CLEAT DADOES**

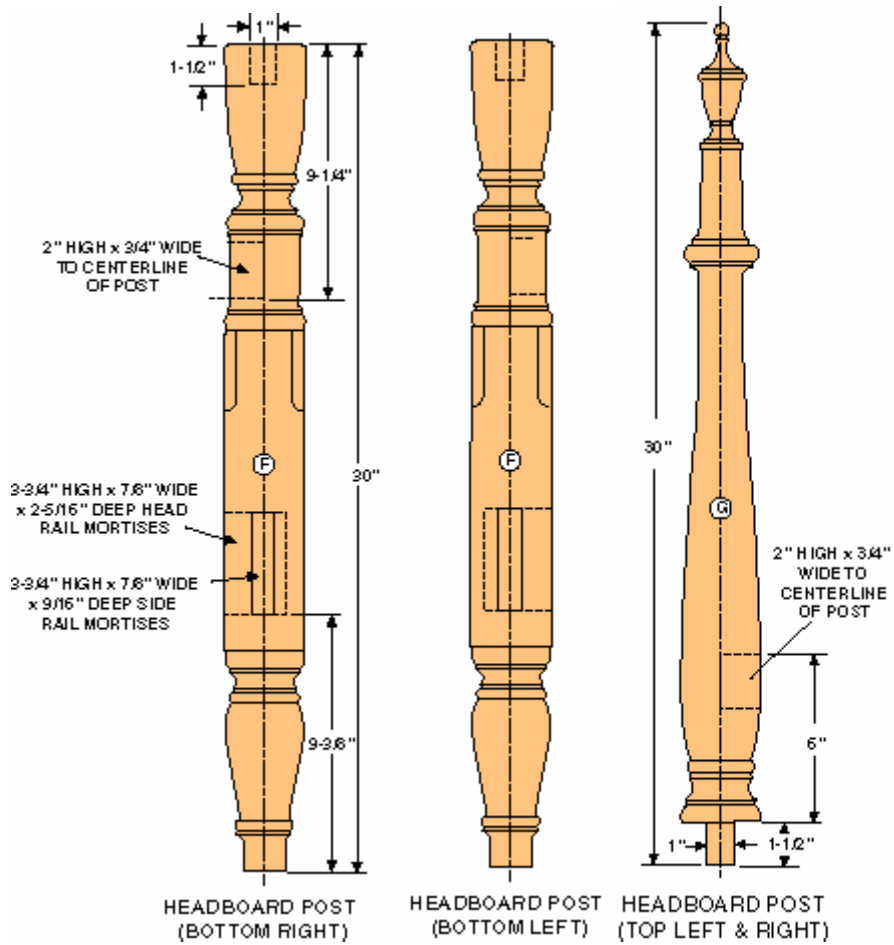

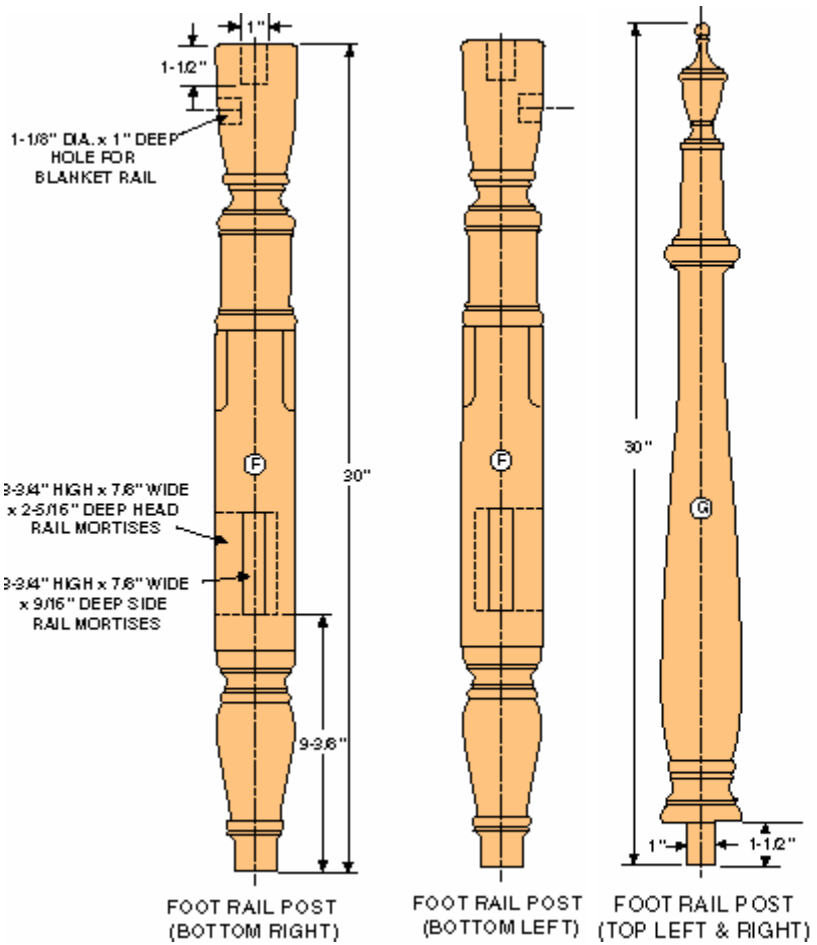

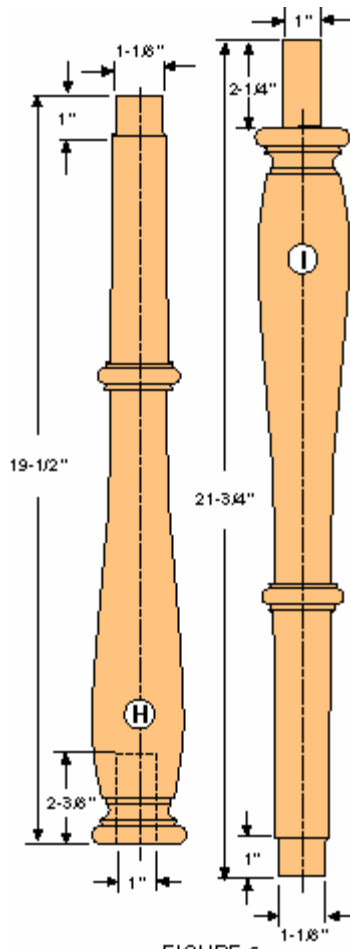

FIGURE 6  
BLANKET RAIL SPINDLES

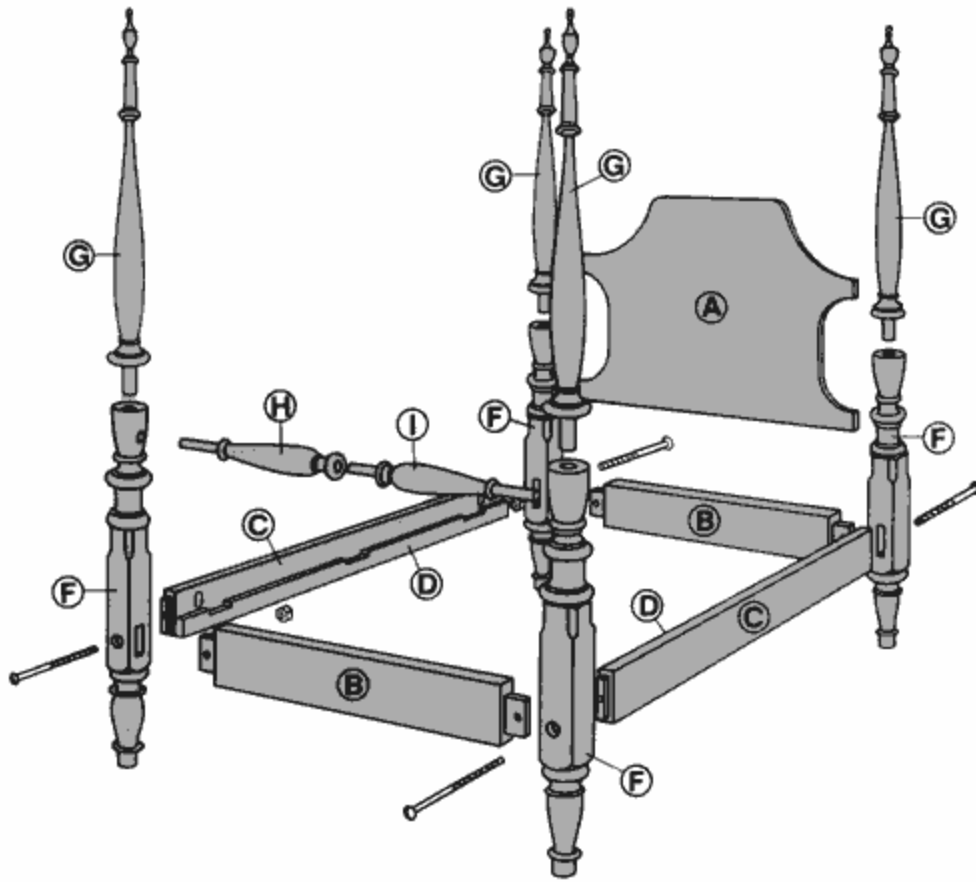
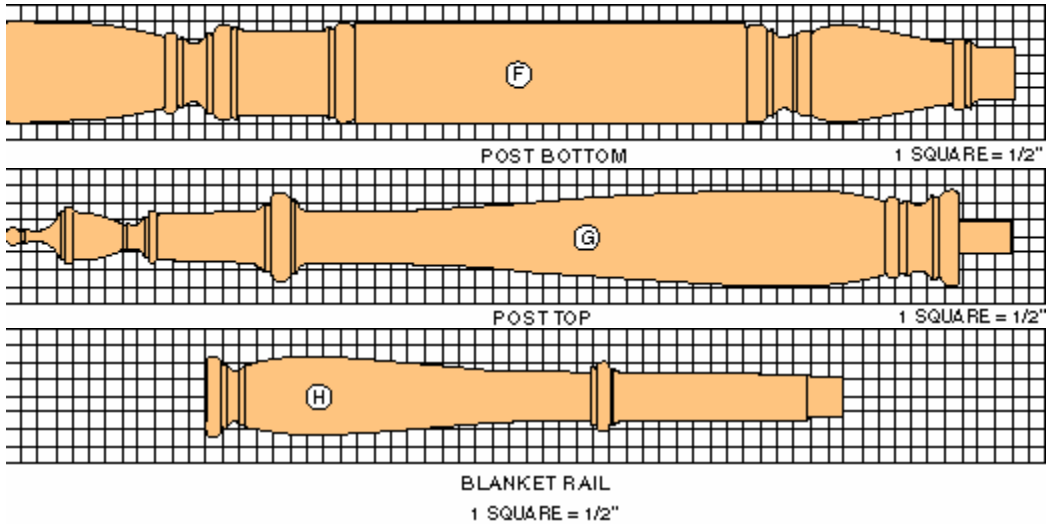

FIGURE 7



**OF MATERIALS**  
(finished dimensions in inches)

**LIST**

A	Headboard	3/4 x 22-1/16 x 39-3/4 *
B	Head & Foot Rails (2)	1-5/8 x 4-1/2 x 41-1/4 *
C	Side Rails (2)	1-5/8 x 4-1/2 x 77 *

D	Side Rail Cleats (2)	3/4 x 1-5/8 x 76 *
E	Slats (3)*	3/4 x 2-1/2 x 38 *
F	Posts -bottom - (4)	3 x 3 x 30
G	Posts - top - (4)	3 x 3 x 30
H	Blanket Rail (1)	2-1/2 x 2-1/2 x 19-1/2 *
I	Blanket Rail with tenon (1)	2-1/2 x 2-1/2 x 21-3/4*

## **HARDWARE**

(4) 3/8" dia. x 6" long bolts with nuts and flat washers (12) 1-1/2" long #8 roundhead wood screws (4) Decorative bolt head covers