

# Calistoga Spa Surround

Enhance the alluring appeal of a backyard spa with this handsome redwood spa surround. Its elegant, custom-crafted design features a comfortable wrap-around lounging bench and two sets of easy-to-build steps, which provide a safe, convenient way in and out of the spa.

For this project, you can use either Construction Common or Deck Common redwood; both grades are economical and offer a rich mixture of heartwood and sapwood. Where increased decay resistance is needed, such as for the 2x4 sleepers, use the all-heartwood grades of redwood: Construction Heart or Deck Heart.

## BUILD A SPA SURROUND

This brochure contains all the information you'll need to construct the redwood spa surround. Start by building the side bench, which includes an attached set of steps. Then assemble the rear bench. Join together the two benches to form the wraparound surround. Note that the building plans and materials lists presented will help you to build a spa surround 28 inches high that will fit a 6x6-foot spa. This project can easily be adapted to fit any size spa.

The easy-to-follow plans include options for bench-board patterns and corner treatments. Select the construction methods that best suit your carpentry skills and personal preferences. There's even an option for converting the unused space under the rear bench into a valuable storage area.

This redwood spa surround is designed to be a freestanding unit. It isn't fastened to the ground in any manner, but simply sits on the concrete slab that supports the spa or rests on a 6-inch deep stone bed. Both styles of base will provide rock-solid support for the spa surround.

Before starting this project, carefully study the plans and materials lists. Remember that it is best to measure and cut as you build for the most accurate results. To prevent staining, use only high quality non-corrosive fasteners.

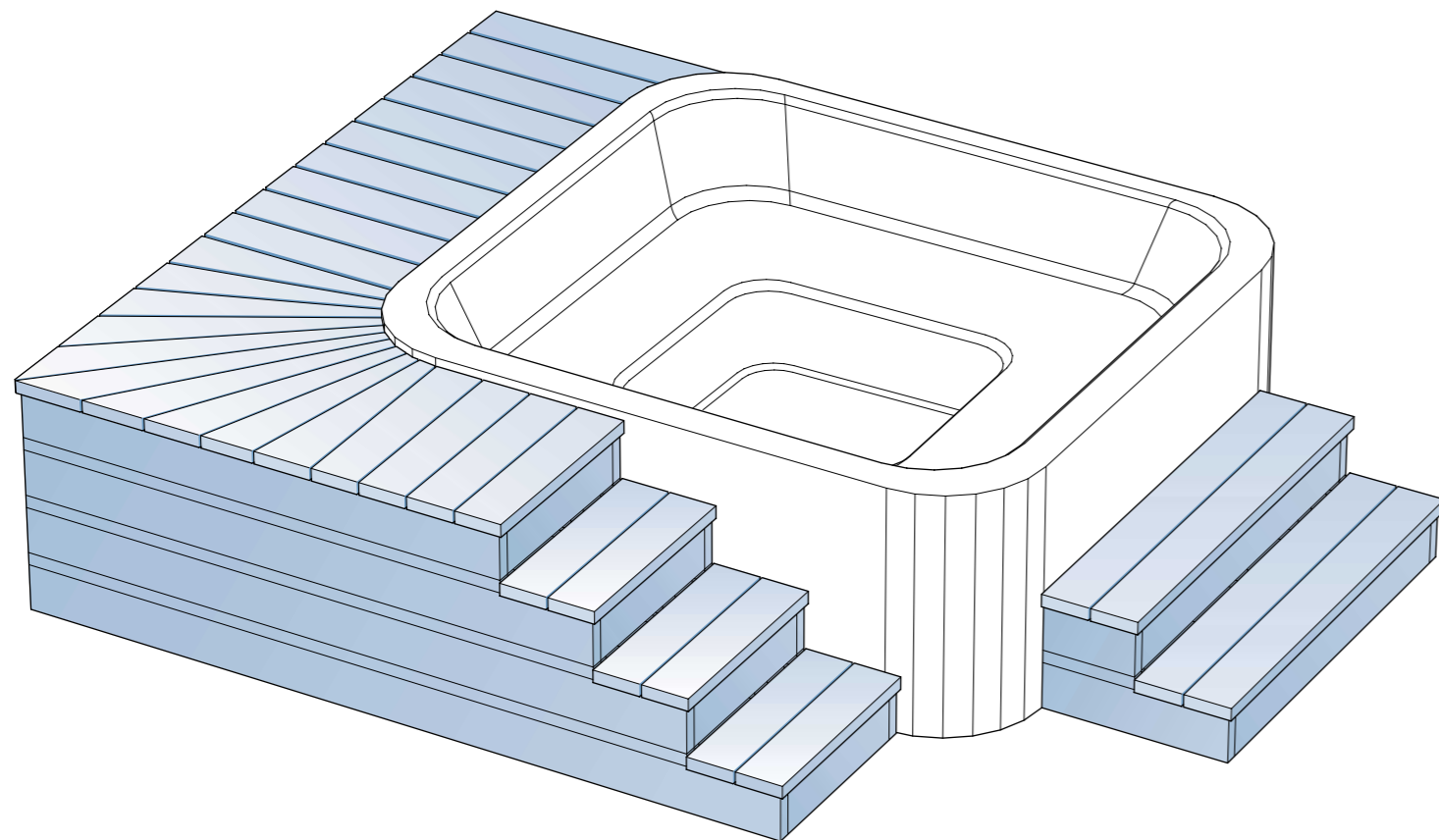

## BUILD SIDE BENCH & STEPS

The skeletal frame of the side bench is primarily constructed out of vertical 2x4s and horizontal 2x6s; narrow 2x2s separate the 2x6 side boards. The entire frame rests on 2x4 sleepers, which form a flat, stable base. The top surface of the bench is made of 2x6s spaced 1/8 inch apart. Fasten the boards together with 3-inch galvanized or stainless steel screws or 10d nails. If you use screws, drive them in with a cordless drill/driver. When assembling the frame, be certain to use a carpenter's framing square to ensure that the parts are perfectly square, meaning they form true 90° angles.

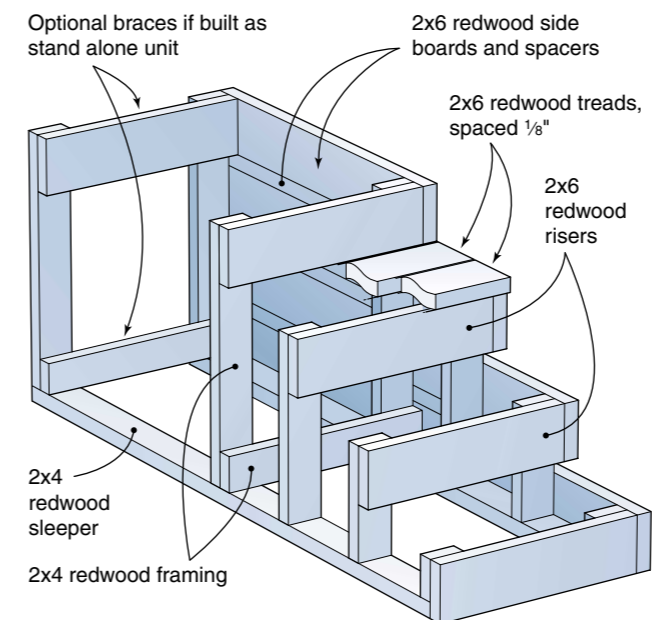
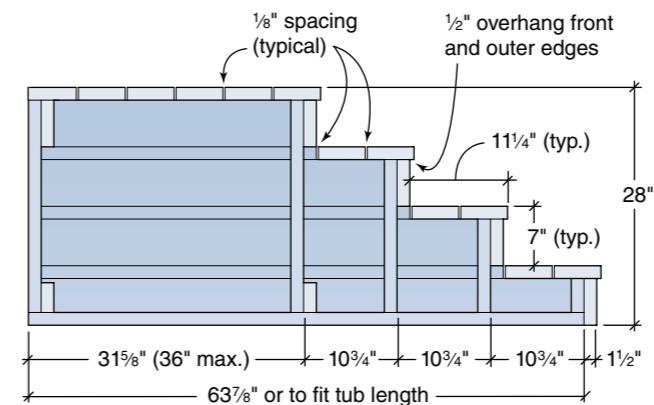

**1. Assemble sleepers and frames** Start by cutting to length the two 2x4 sleepers. (For a 6x6-foot spa, cut them to 63 7/8 inches.) A power table saw provides a quick, accurate way to crosscut lumber, but a portable circular saw or handsaw will work just as well.

Next, cut the five pairs of vertical 2x4 frames. Note that two pairs (four pieces) are 25 inches tall, while the remaining pairs are 18, 11 and 4 inches tall. These tiered pairs form the three steps and accommodate spas 28-29 inches tall. Ideally, the spa surround should be slightly lower than the spa edge. Cut the 2x4s shorter or longer to fit a spa of different height. Mark the positions of the vertical 2x4s on the sleepers, and then attach them with screws or nails driven up through the bottom of the sleepers.

**2. Attach step risers** Cut four 2x6 risers to length and fasten them flush with the top of the vertical 2x4s. Drive the fasteners in from the back of the 2x4s so they won't show.

**3. Side boards and spacers** Cut only enough 2x6 side boards and 2x2 spacers to fit across the spa-side length and the end of the partially assembled bench. The outside side boards and spacers will be trimmed to fit and installed later after the two benches have been joined. Use the carpenter's square to make certain that the 2x4 frames are true vertical before securing any side boards. Starting at the bottom, fasten a 2x6 to the side of the frame that will face the spa. Place a 2x2 spacer above the 2x6 and fasten it to the frame. Repeat for the end of the frame. Continue alternating 2x6s and 2x2s until you reach the top of the frame. (See Design Options for Corner Treatment details.) Slide the bench into position alongside the spa, but don't attach the side boards to the outside surface just yet.

**4. Attach step treads** You can attach the treads now or wait until installing all the bench boards. Trim six 2x6 boards to 24 1/2 inches. Set the boards into place, starting them even with the spa-side framing and overhanging the outside edge by 1/2 inch. Allow 1/8-inch spaces between treads and at the riser/tread joint.

## BUILD REAR BENCH

The rear bench is constructed much like the side bench using redwood 2x2s, 2x4s and 2x6s. The main difference between the two structures is that the vertical 2x4 frames of the rear bench are all the same height since they don't have to form a set of steps.

Before starting on the rear bench decide on the type of bench-board pattern you'd like; see the section on Spa Surround Design Options. No special consideration is needed for laying the right-angle board pattern, but you'll have to install additional bracing for the 45° or sunburst patterns; see Special Framing Details below.

Also, if you'd like to utilize the space beneath the rear bench for storage, check out the Storage Access Option. It provides detailed instructions on how to frame out a 48-inch-wide opening and build two swing-out doors.

**1. Assemble framing** As with the side bench, start by cutting to length the two 2x4 sleepers. For maximum decay resistance, use an all-heartwood grade of redwood, such as Construction Heart or Deck Heart. Cut all the vertical 2x4 frame parts to 25 inches (for a 28-inch-tall spa). Cut the horizontal 2x4 frame parts to 21 inches to ultimately create a bench that's 24 inches wide. Use 10d nails or 3-inch deck screws to fasten together the parts

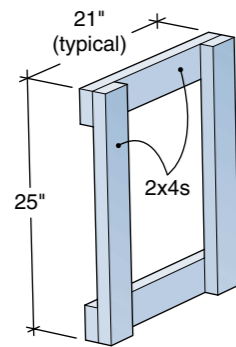

to make five identical frames, each measuring 21 inches wide by 25 inches tall. Again, be sure to use non-corrosive fasteners.

Trim the 2x4 sleepers to fit the length of the spa plus the width of the side bench framing—about eight feet. Fasten the assembled frames to the sleepers, making certain that they're evenly spaced. If your spa requires a longer bench, you will need longer sleepers and additional frames. Keep the frame spans equal and spaced no more than 24 inches on center (o.c.).

Before placing the bench frame into position alongside the spa, install the 2x2 spacers and 2x6 side boards to the surface that goes up against the spa. But, don't cover the entire side. Fasten one continuous 2x6 along the entire bottom of the bench frame and another along the top. Then cut three 2x2 spacers and two 2x6 side boards to span the distance from the first frame to the second frame. These boards help conceal from view the open space beneath the bench. (They'll also prevent cats and other critters from crawling under the bench.)

**2. Join rear and side benches** Place the partially completed bench into position against the rear of the spa. Check to make sure that it's properly aligned with the side bench and that the two structures form an exact right angle. Fasten together the two benches with several nails or screws.

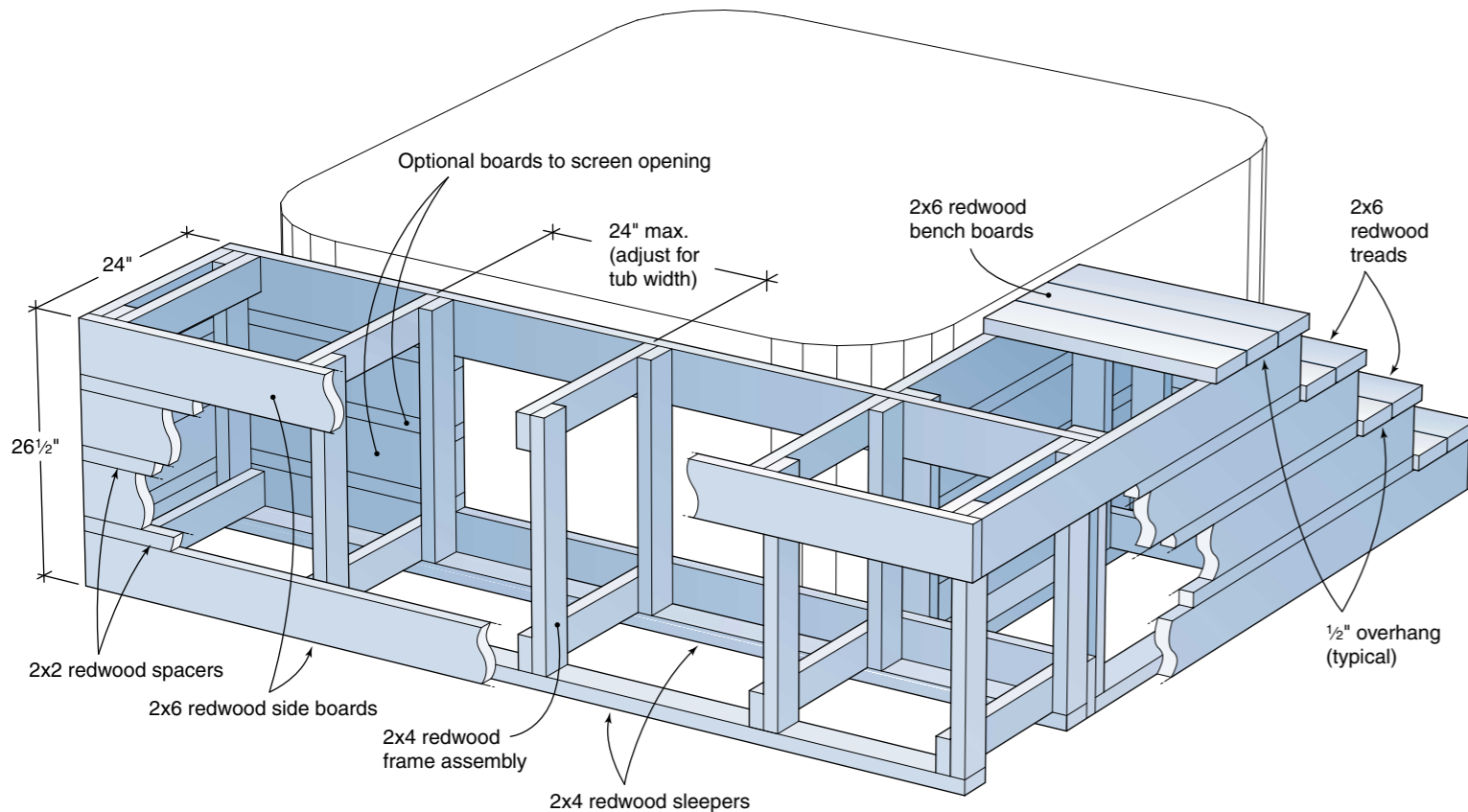

**3. Attach side boards** With the two benches joined together, you can continue installing the side boards and spacers. Begin with the boards on the end of the rear bench. Fasten the bottommost 2x6 side board, then work your way up to the top of the bench alternating a 2x6 with a 2x2. Move around to the back of the rear bench and repeat the process. Again, start with a 2x6 and align each board with its mating member on the end of the bench.

Once the end and back of the rear bench are covered, install the 2x6 side boards and 2x2 spacers to the side bench. Note that these pieces extend all the way across both the side bench and the end of the rear bench, thus hiding the joint between the two.

**4. Install bench boards** Cover the tops of both benches and the steps with redwood 2x6s. For the steps, cut the boards so that they overhang the side boards by exactly 1/2 inch. Cut the bench boards slightly long and trim them to fit afterwards. Use 16d nails to help space the boards 1/8 inch apart. Fasten each one with four 10d nails or 3-inch deck screws flush to the bench surface; do not countersink. When you get to the corner of the tub, you will want to cut the boards to fit the tub radius allowing for a 1/4- to 3/8-inch drain space. Make a cardboard template of the tub corner. Lay out your bench boards on a flat surface including the 1/8-inch spaces. Transfer the trim line from the template and trim and install the corner bench boards.

**5. Trim bench boards** To achieve a professional looking cut, use a circular saw to trim the ends of all the overhanging boards at the same time. Measure 1/2 inch out from the side board and use a chalk reel to snap a line across the top surface of the boards. (You could also use a long straight-edged board.) Guide the saw along the line to trim off the overhanging bench boards. Smooth out any rough edges and ease all sharp corners with 100-grit sandpaper.

**Finishing** To protect the visual beauty of your project and extend its life, finish the exposed surfaces with a clear water repellent containing a mildewcide. See the finishes section on the address panel of this brochure for more finish options.

## TOOLS AND MATERIALS

**Tools you will need** To build this redwood spa surround, you'll need a power miter saw, sabre saw, circular saw or fine-tooth handsaw, hammer, cordless drill/driver, measuring tape, chalk reel, carpenter's square, combination square, and hand plane or belt sander. A small clamp would also be helpful for holding together the frame parts while you drive in the nails or screws.

Fasteners should be top quality hot-dipped galvanized or stainless-steel nails or screws. The lists below itemize the sizes and amounts of redwood needed to build the spa surround framing and steps.

### Materials For 6-Foot Side Bench and Steps

	Quantity	Size	Length
Vertical frames (from two 8-foot 2x4s)	4	2x4	25 inches
	2	2x4	18 inches
	2	2x4	11 inches
	2	2x4	4 inches
Sleepers	2	2x4	8 feet/to fit
Side boards	8	2x6	8 feet/to fit
Side spacers	8	2x2	8 feet/to fit
Short side boards	4	2x6	21 inches
Short side spacers	4	2x2	21 inches
Step risers	4	2x6	24 1/2 inches
Step treads	6	2x6	24 1/2 inches
Bench boards	See bench-board patterns materials list		
Fasteners	2 pounds	10d common nails or 3-inch deck screws	

### Materials For 8-Foot Rear Bench

	Quantity	Size	Length
Vertical frames	10	2x4	25 inches
Top and bottom frames	10	2x4	21 inches
Sleepers	2	2x4	10 feet/to fit
Spa-side back boards	2	2x6	10 feet/to fit
Side boards	4	2x6	10 feet/to fit
Side spacers	3	2x2	10 feet/to fit
Short side boards	4	2x6	21 inches
Short side spacers	3	2x2	21 inches
Optional side boards	4	2x6	27 inches
Optional spacers	3	2x2	27 inches
Bench boards	See bench-board patterns materials list		
Fasteners	2 pounds	10d common nails or 3-inch deck screws	

## SPA SURROUND DESIGN OPTIONS

The building plan for this redwood spa is flexible enough to permit several design options. Below are examples of four different corner treatments and three bench-board patterns from which you can choose. And best of all, none of these design options requires a significant increase in the amount of time or materials needed to complete the surround.

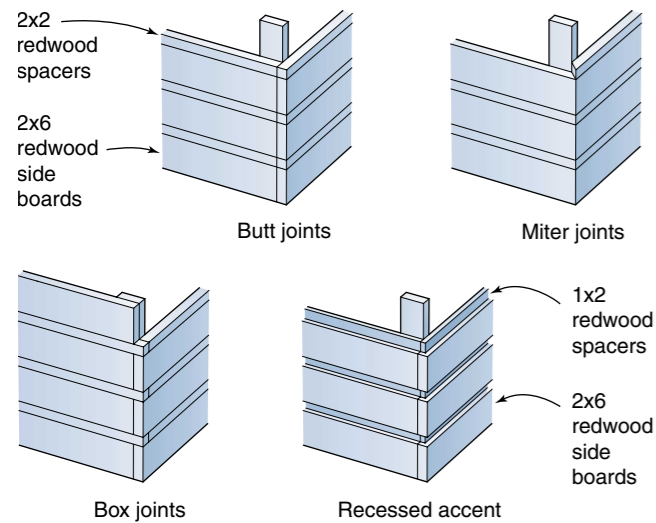

**Corner treatments** The outside corner joints, where the side boards and spacers meet at right angles, can be fitted together in many ways. The easiest approach is to alternately stack the side boards and spacers using either butt joints or box joints. For a visually cleaner look, use miter joints; recommended for well-seasoned (dry) lumber only. To create a series of interesting shadow lines around the spa surround, choose the recessed-accent option and separate the 2x6 side boards with smaller 1x2 spacers.

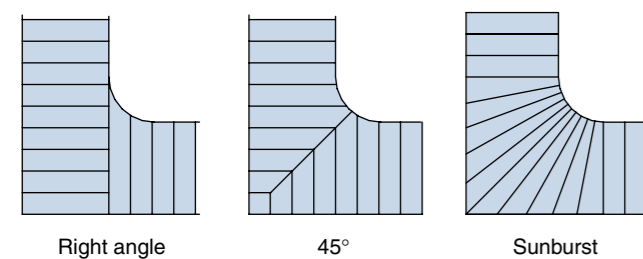

**Bench-board patterns** The right-angle bench-board pattern shown above is by far the easiest to build, but the 45° and sunburst patterns are much more interesting. Remember that these two patterns require the installation of additional framing to support the 2x6 bench boards; see Special Framing Details at right.

## SPECIAL FRAMING DETAILS

### Bracing for 45° pattern

In this popular pattern, the 2x6 bench boards from the side and rear benches meet at the bench corner. As a result, there's a seam running diagonally across the bench. To support the board ends along this seam, install a pair of notched 4x4 posts and a double-2x4 cross brace. Cut a 3½-inch-deep notch into the top of each post. Before nailing together the double-2x4 brace, slip three short strips of ½-inch plywood between the 2x4s, to allow water to drain through to the ground.

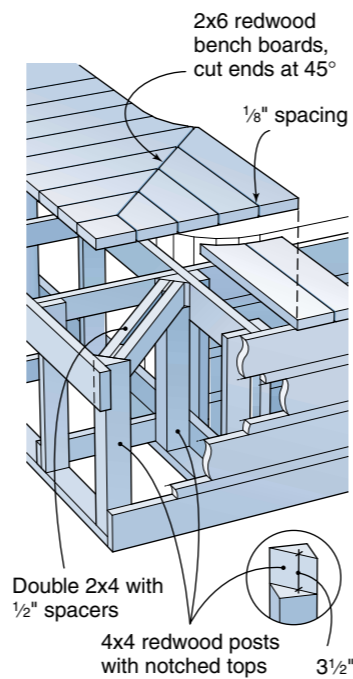

**Bracing for sunburst pattern** The bench boards for this attractive pattern require additional bracing because they are cut to a taper and span too great a distance. To install a diagonal brace across the bench corner, cut the ends of a 2x4 to 45° and nail it in place.

**Trimming boards for a sunburst pattern** To make this job easier, create a template of the corner construction on a large piece of plywood or cardboard, as shown below. Establish the diagonal starting line across the bench corner. Lay the first 2x6 board on the starting line. As you add boards remember to space the boards ⅛ inch apart.

Mark the tapered cutting line from the inside corner of the board to where its outside edge would meet the bench frame. Cut the taper with a circular saw and repeat for the other boards, making sure you leave the ends running long.

Make a cardboard template of the spa's rounded corner and use it to mark the curved cut line onto the board ends. Trim boards with a hand or sabre saw. Fasten the trimmed boards in place on the bench frames with deck screws or nails. Pre-drill nail holes at the board ends to prevent splitting. Trim all the bench boards to length, leaving a ½-inch overhang.

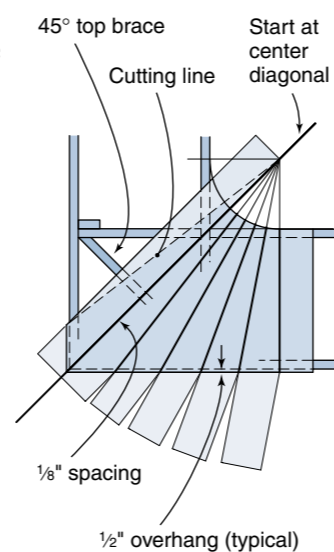

## STORAGE ACCESS OPTION

Take advantage of the empty space beneath the rear bench by building a convenient storage compartment. Its opening measures about 21 inches high by 48 inches wide and is concealed behind two easy-to-assemble doors.

**1. Framing details** Build the structural frames of the rear bench out of 2x4s and space them 24 inches apart, as shown below. Note that each frame is made up of four 2x4s, except the center frame. It only has one vertical 2x4 and one horizontal 2x4. The front and bottom pieces are purposely left out to create the wide-open, easy-access storage area.

When installing the 2x6 side boards and 2x2 spacers, cut them flush with the vertical 2x4 frames on each side of the opening. Fasten a long, continuous 2x6 at the top of the opening and allow the 2x4 sleeper to run across the very bottom of the compartment.

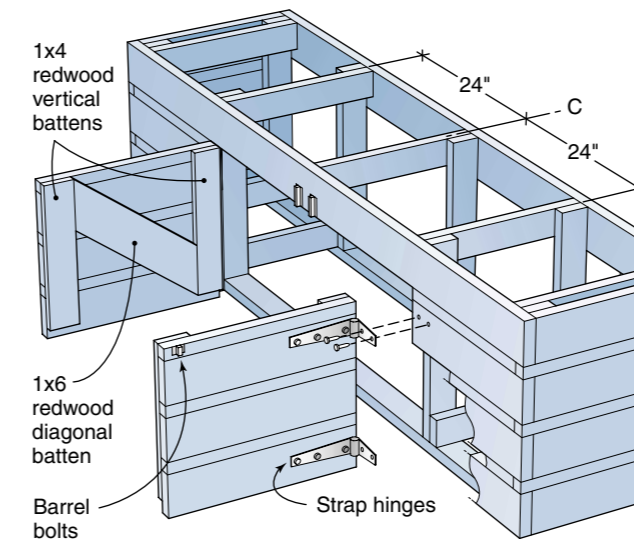

**2. Assemble storage doors** Build the two doors out of alternating 2x2s and 2x6s to match the surround. Cut the boards to length, then lay them face down. Make sure they are square and use a clamp to hold the doors while you fasten the boards together. Attach two vertical 1x4 battens and a diagonal 1x6 batten strip across the joints. Note that the 1x4 battens are positioned 1¾ inches up from the door bottom in order to clear the 2x4 sleeper.

**3. Trim to fit** Test fit the doors in the opening. If they fit too tightly, trim ⅛-¼ inch from the top and side of each door with a belt sander or hand plane.

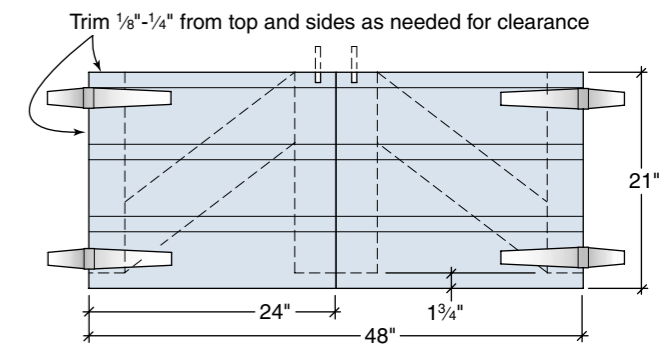

**4. Hinges** Hang each door with a pair of galvanized metal strap hinges. You can attach the hinges with the short wood screws provided but, for maximum strength, replace them with ⅜-inch by 2-inch galvanized lag screws. Drill ⅜-inch screw pilot holes into the doors and screw on the hinges. Set the doors in the opening and use shims to hold them in place. Drill pilot holes into the 2x6 side boards and attach the second hinge leaf with lag screws.

These lists detail the materials needed for each bench-board pattern and any special framing, if required, along with the additional framing and hardware needed for the storage access.

### Materials For Bench-board Patterns

	Quantity	Size	Length
<b>45° pattern</b>			
Board boards	13	2x6	24½ inches
Corner bench boards	6	2x6	trim to 45° to fit
Braces	2	2x4	29 inches/to fit
Spacers	3	scrap ½-inch plywood	
<b>Sunburst pattern</b>			
Corner bench boards	8	2x6	4 feet/to fit
Bench boards	13	2x6	24 inches
Brace	1	2x6	29 inches/to fit
<b>Right angle pattern</b>			
Bench boards	8	2x6	24½ inches

### Additional Materials For Storage Access

	Quantity	Size	Length
Vertical battens	4	1x4	25⅜ inches
Diagonal battens	2	1x6	31 inches
Strap hinges	4		
Barrel bolts	2 sets with wood screws		
Lag bolts, nuts and washers	as needed		⅜ x 2 inches

## STAND ALONE STEPS

This optional set of steps is constructed very much like the spa surround. It has a 2x4 frame and 2x6 side boards separated by 2x2 spacers. The treads and risers are cut from 2x6s. For maximum safety and convenience, build the steps long enough to span the entire width of the spa. The steps illustrated here are 48 inches long, but you can easily adjust the dimensions to fit any spa. When you add framing, keep the spans at 24 inches o.c. or less.

**1. Assemble the framing** Begin by cutting the three 2x4 sleepers to 18<sup>3</sup>/<sub>8</sub> inches long. Next, make the nine vertical 2x4 frame parts; cut six of them to 11 inches long and three to 4 inches long. Nail or screw the vertical 2x4s to the sleepers, as shown. Cut two 2x6 back boards and one 2x2 spacer to 45 inches. Attach these boards to the three sleeper/framing assemblies, positioning one assembly at each end and one in the middle.

**2. Install inner boards and side boards** Cut to length the 2x6 side boards and spacers. Attach two side boards and one spacer to each end of the step assembly. Next, trim to fit two 2x6 inner boards and fasten them to the middle 2x4 frame.

**3. Attach risers and treads** Each step tread consists of two 2x6s and each riser is made up of a single 2x6. Saw the four tread boards to 49 inches; cut each riser to 45 inches. Fasten the two risers to the vertical 2x4 framing members. Set the 2x6 treads into place. Check to make sure that their ends overhang by 1/2 inch and that there's a 1/8-inch space between the boards. Secure each tread with six 10d non-corrosive nails or 3-inch deck screws.

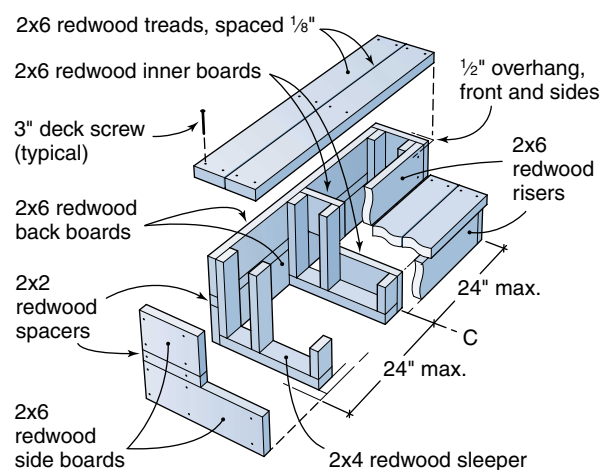
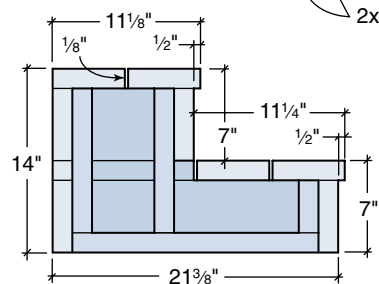
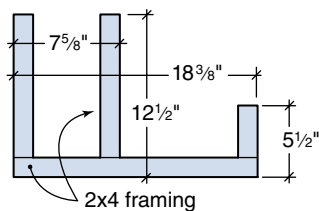
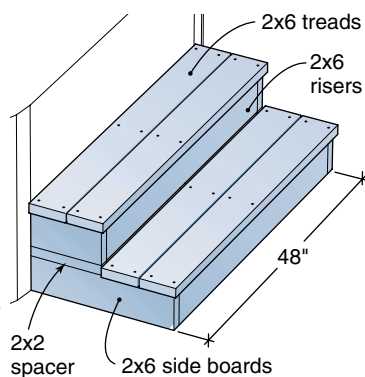

### Materials For 48-inch Stand Alone Steps

	Quantity	Size	Length
Sleepers	3	2x4	18 <sup>3</sup> / <sub>8</sub> inches
Vertical frames	3	2x4	4 inches
	6	2x4	11 inches
Inner boards	1	2x6	7 <sup>5</sup> / <sub>8</sub> inches
	1	2x6	12 <sup>1</sup> / <sub>4</sub> inches
Side boards	2	2x6	10 <sup>5</sup> / <sub>8</sub> inches
	2	2x6	21 <sup>3</sup> / <sub>8</sub> inches
Side spacers	2	2x2	10 <sup>5</sup> / <sub>8</sub> inches
Risers, back boards	4	2x4	45 inches
Back spacer (optional)	1	2x2	45 inches
Treads	4	2x6	49 inches
Fasteners	1 pound	8d common nails or 2 1/2-inch deck screws	
	1 pound	10d common nails or 3-inch deck screws	

Contact the California Redwood Association for more great publications containing redwood technical and building information. Call us toll free at 1-888-Cal-Redwood for a complete literature list or to ask for any of the titles listed here:

### Other Construction Tipsheets Also Available

Freestanding Deck	Deck Construction
Deck Over Concrete	Deck Grades, Nails and Finishes
Windsor Shade Shelter	Fences for All Reasons
Monterey Potting Center	Landscape Architecture
Mendocino Bench	
Lake Tahoe Gazebo	
Petaluma Planters	
Sonoma Picnic Table	

## Redwood

For beauty and performance, redwood is naturally superior to other woods. That's why it's the first choice for decks, fences and most outdoor projects. Redwood retains its beauty outdoors, shrinks and swells less than other woods and is less likely to warp, split, check or cup. With relatively little or no pitch, redwood is easy to drill, saw and shape. Redwood heartwood has natural durability and resistance to insects and will last longer outdoors than most woods.

## Grades

The knotty garden grades of redwood are ideal for outdoor projects. These grades are beautiful, durable and economical.

**Construction Heart/Deck Heart** is all heartwood and contains knots; used for load-bearing applications near the ground. Deck Heart is graded for strength and is available in 2x4 and 2x6.

**Construction Common/Deck Common** contains sapwood and knots; used for decking and above-ground uses. Deck Common is graded for strength and is available in 2x4 and 2x6.

**Merchantable Heart** is all heartwood and contains larger knots than Construction grades; used near the soil.

**Merchantable** contains sapwood and larger knots; used for fence boards, rails and above-ground uses.

## Finishes

Redwood accepts finishes better than most woods. Some heighten redwood's natural beauty, bringing out the color and the grain. Others help the wood harmonize or contrast with surrounding structures. Read the labels on all finish products before using.

**No-finish option** Redwood performs better than most woods if left unfinished. This no-maintenance option will result in redwood weather-bleaching to a soft driftwood gray.

**Clear water repellent finish** with mildewcide is recommended to stabilize the color at tan.

**Bleaching and weathering stains** produce a permanent driftwood gray effect, a good, low-maintenance option.

**Semitransparent stains** in "redwood" shades tint the wood without hiding the grain.

**Solid-color stains or paints** should be applied over compatible oil-based primers.

## Fasteners

Use only non-corrosive hardware such as aluminum, stainless steel or top quality hot-dipped galvanized screws or nails. Ordinary nails and screws will cause stains.



405 Enfronte Drive, Suite 200  
Novato, CA 94949-7206  
Telephone 415 382-0662  
Toll Free 888 Cal-Redwood  
Fax 415 382-8531  
[www.calredwood.org](http://www.calredwood.org)