



Shop Notes

Kitchen Cabinet Roll-Out Shelves

Every kitchen I've worked in has seen me on my hands and knees rooting around in back of the lower cabinets. Roll-out shelves like these make those spaces a lot more convenient.

The roll-out consists of a drawer suspended in an outer tray on side-mounted drawer glides. The dimensions given here are suited to my cabinets, 3/4" thick lumber and drawer glides 1/2" thick. Dimensions should be adjusted to suit your lumber, drawer glides, and cabinet dimensions.

The tray and drawer could be assembled with butt joints secured by countersunk screws. Since I spent way too much on a very good dovetailing machine, I treat these projects as an opportunity to try different dovetail types and arrangements. (and not incidentally to justify the purchase of the machine in the first place)

The bottom of the outer tray is 1/4" plywood glued and nailed in place. My habit is to cut the bottoms oversized, then trim off with a flush-cutting router bit later. The drawer bottom could be done the same way as well. I prefer to run a groove around the inside of the drawer and insert a 1/4" plywood bottom. If I need to make an unusually large drawer, I'd probably rabbet the perimeter of a piece of 1/2" plywood and let that into a groove instead.

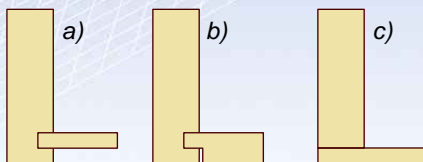

Drawer bottom possibilities.
 a) inset 1/4" plywood
 b) rabbeted 1/2" plywood
 c) flush trimmed 1/4" plywood



Section through finished roll-out.

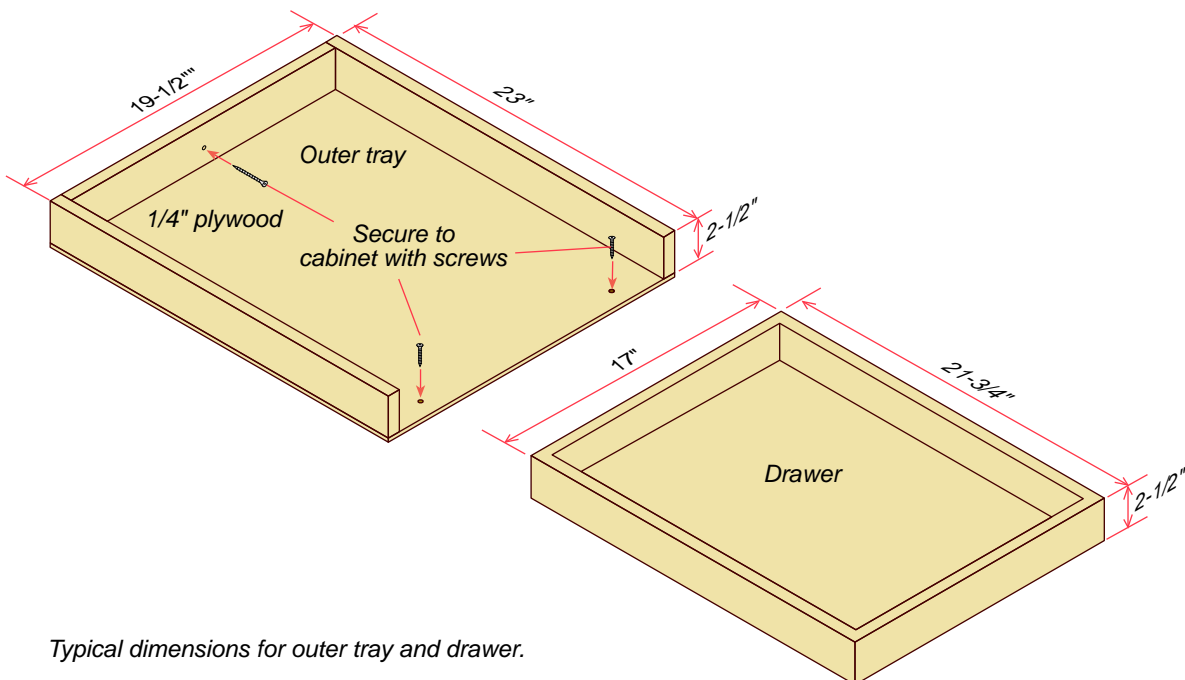

Typical dimensions for outer tray and drawer.