



Wow! I Made It.com

## **K**itchen Island Topper

*We love this great island topper. It keeps everyday china accessible—plates for sandwiches or bowls for morning cereal—and it frees up lots of kitchen cabinet space. When we moved into a new house, we hung it from the ceiling over the kitchen island, which then freed up island space.*



## **Materials List**

- 8 linear feet of 1 x 1 pine
- 22 linear feet of 3/8"-diameter wooden dowel rod
- 12 linear feet of 1 x 10 pine
- 5 linear feet of 2 x 2 pine
- 9 linear feet of 1 x 12 pine
- 8 linear feet of 3/4"-wide cove molding

## **Hardware**

- 50 1" (2d) finishing nails
- 20 1-1/4" (3d) finishing nails
- 30 1-5/8" wood screws

## **Special Tools and Techniques**

- Router and a round-over bit (optional)
- Bar clamps
- Miter

## **Cutting List**

Code	Description	Qty	Material	Dimensions
A	Rack Support	4	1 x 1 pine	22-1/2" long
B	Rack Rod	18	3/8"-diameter dowel rod	14" long
C	Inner Vertical	2	1 x 10 pine	14" long
D	Shelf	2	1 x 10 pine	11-3/4" long
E	Shelf Support	4	2 x 2 pine	14" long
F	Inner Top/Bottom	2	1 x 10 pine	47-1/2" long
G	Top/Bottom	2	1 x 12 pine	49-1/2" long
H	Cove Molding	8	3/4"-wide cove molding	cut to fit

## **Making the Plate Rack**

1. Cut four Rack Supports (A) from 1 x 1 pine, each measuring 22-1/2 inches.
2. Holes must be drilled in each of the four Rack Supports (A) to accommodate the dowel rods that hold the plates. It is very important that the holes are accurate and straight, or your finished plate rack will be crooked. Refer to the measurements in *Figure 1*, and drill nine 3/8"-diameter holes in one Rack Support (A). Note that the holes are centered widthwise on the Rack Support (A), and 2-1/4 inches apart on center.

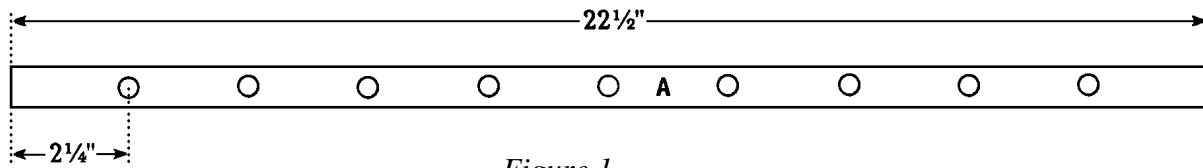

Figure 1

3. Use the drilled Rack Support (A) as a template to drill holes in each of the remaining three Rack Supports (A).
4. Cut 18 Rack Rods (B) from 3/8"-diameter dowel rod, each measuring 14 inches.
5. Place one Rack Support (A), with holes up, on a flat surface. Apply glue to one Rack Rod (B), and insert it in the first hole in the Rack Support (A). Make certain that the Rack Rod (B) is completely through the hole, and flush with the bottom surface of the Rack Support (A).
6. Repeat Step 5 eight more times to insert eight more Rack Rods (B) in the first Rack Support (A). Let the glue set up for several hours.
7. Place a second Rack Support (A) on a level surface. Turn the Rack Rod/Support assembly upside-down, Apply glue to the exposed ends of each of the Rack Rods (B), and insert them in the corresponding holes in the second Rack Support (A) to form a ladder arrangement, as shown in *Figure 2*.
8. Repeat Steps 5 through 7 to assemble the second rack assembly, using the remaining nine Rack Rods (B), and remaining Rack Supports (A).

### ***Assembling the Shelf Sections***

1. Cut two Inner Verticals (C) from 1 x 10 pine, each measuring 14 inches.
2. Cut two Shelves (D) from 1 x 10 pine, each measuring 11-3/4 inches.
3. Cut four Shelf Supports (E) from 2 x 2 pine, each measuring 14 inches.
4. An optional step at this point is to cut two 1/8 x 1/8" grooves on all four sides of each Shelf Support (E).
5. Place one Shelf (D) on a flat surface. Refer to *Figure 3* to mark the cutout to accommodate a Shelf Support (E) in the two outer corners of the Shelf (D). Place the end of one Shelf Support (E) exactly in place, and trace around it. Remove the Shelf Support (E), and cut out each of the two corners, which you marked in the Shelf (D).

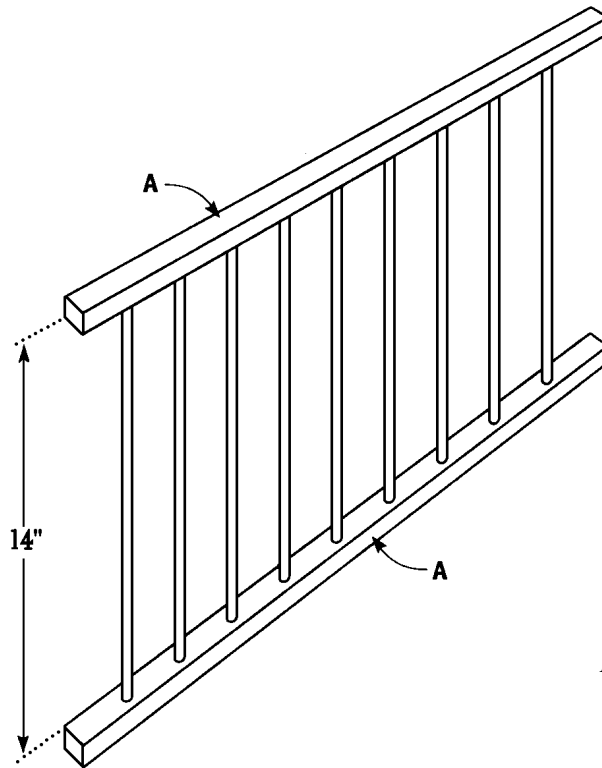

Figure 2

6. Repeat Step 5 to cut out the corners on the remaining Shelf (D).
7. Place one Inner Vertical (C) on edge, on a flat surface. Center the Shelf (D) over the Inner Vertical (C), with the cutouts facing up, as shown in *Figure 4*. Apply glue to the meeting surfaces, and screw through the Inner Vertical (C) into the edge of the Shelf (D), using four 1-5/8" screws.

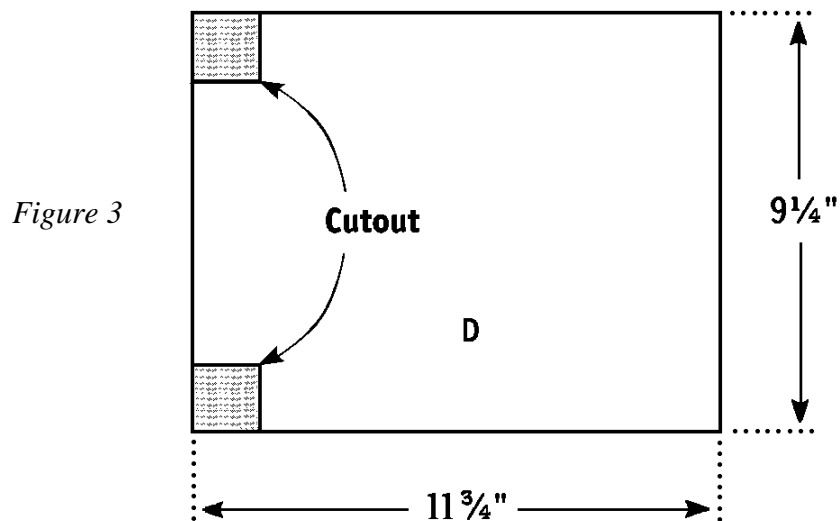

Figure 3

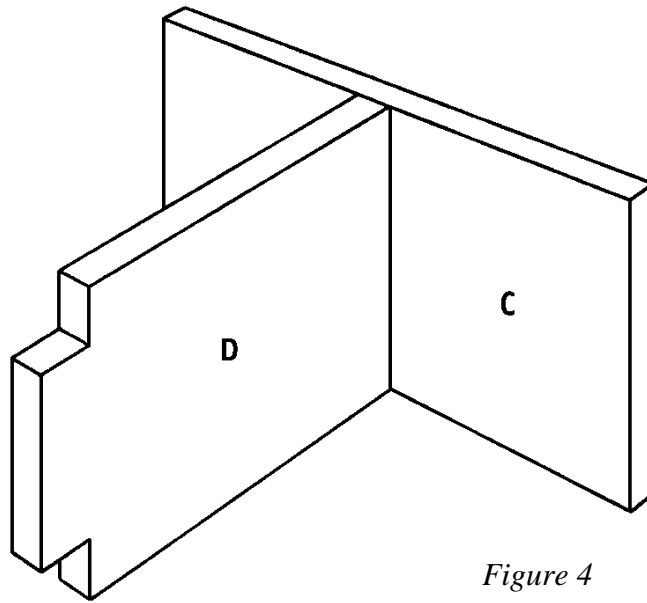

Figure 4

### **Cutting the Top and Bottoms**

1. Cut two Inner Top/Bottoms (F) from 1 x 10 pine each measuring 47-1/2 inches.
2. Cut two Top/Bottoms (G) from 1 x 12 pine, each measuring 49-1/2 inches.
3. An optional step at this point is to use a router and a round-over bit to finish the edges of each of the two Top/Bottoms (G).

### **Assembly**

1. Place the two Inner Top/Bottoms (F) on edge on a level surface, parallel to each other and 14 inches apart. Fit one rack/rod assembly (centered lengthwise) between the two Inner Top/Bottoms (F), as shown in *Figure 5*. Place one shelf assembly on each end of the centered rack/rod assembly. Apply glue to the meeting surfaces, clamp the assembly together to hold it in position, and screw through the Inner Verticals (C) into the ends of the rack/rod assemblies, using a 1-5/8" screw on each joint.
2. Apply glue to the meeting surfaces, and screw through the Inner Top/Bottoms (F) into the edge of each Inner Vertical (C), using three 1-5/8" screws on each joint.
3. Apply glue to the meeting surfaces, and fit the Shelf Supports (E) between the Inner Top/Bottoms (F), and into the cutout corners of the Shelves (D). Screw through the Inner Top/Bottoms (F) into the ends of each Shelf Support (E), using a 1-5/8" screw on each joint.

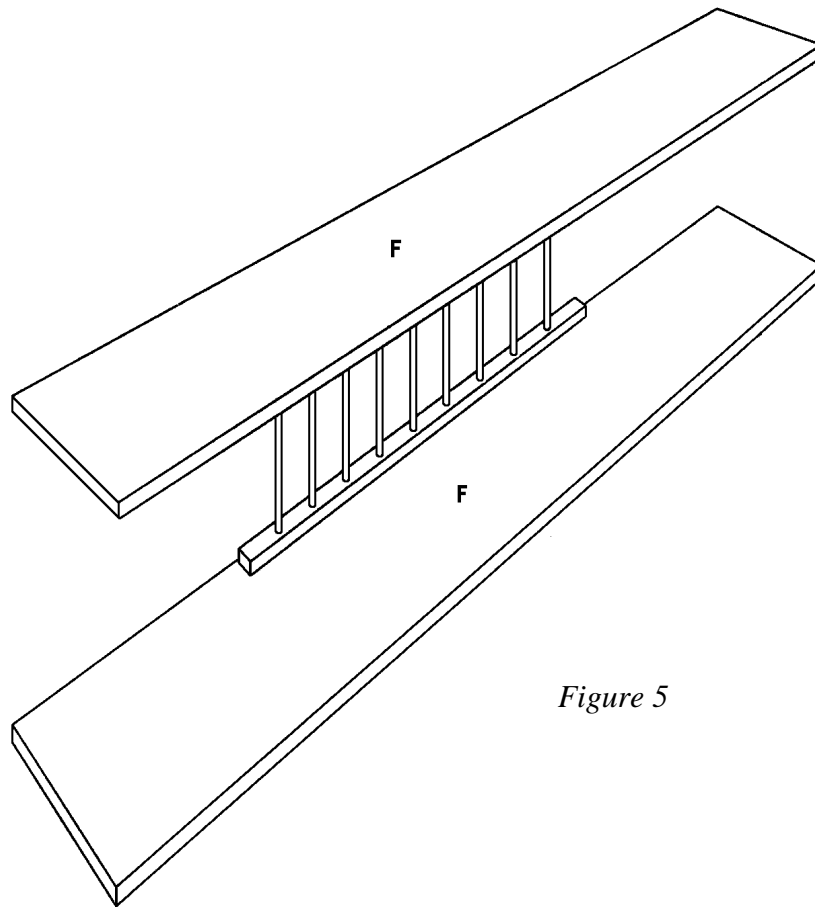

*Figure 5*

4. Apply glue to the meeting surfaces, and center one Top/Bottom (G) on one Inner Top/Bottom (F). There should be a 1"-wide overhang on all sides. Nail through the Top/Bottom (G) into the Inner Top/Bottom (F) using 1-1/4" nails. Use three nails on each end, and about five nails along each side.
5. Turn the assembly upside-down, and repeat Step 4 to attach the remaining Top/Bottom (G) to the remaining Inner Top/Bottom (F).
6. Miter cut and fit  $\frac{3}{4}$ "-wide cove molding (H) over the joining of the lower Inner Top/Bottom (F) and the lower Top/Bottom (G). Apply glue to the meeting surfaces, and nail through the cove molding into the Top/Bottom (G) using 1" finishing nails spaced about every 4 inches.
7. Turn the assembly upside-down and repeat Step 6 to attach cove molding to the joining of the remaining Inner Top/Bottom (F) and Top/Bottom (G).

## ***Finishing***

1. Fill any holes, cracks or crevices with wood filler.
2. Thoroughly sand all areas of the completed island topper.
3. Paint or stain the island topper with the color of your choice. We chose a very light pine stain, and then sealed it with satin polyurethane.



---

**Enjoy other indoor and outdoor projects from**

