

# Bunk Bed

This design has been made both functional and attractive by use of pattern cut-outs in head and foot uprights, which serve as ladders. Since most children love to climb, getting them to bed will be less of a chore.

Beds may be put up or taken down quickly by use of a simple bolted connection at rails and uprights.

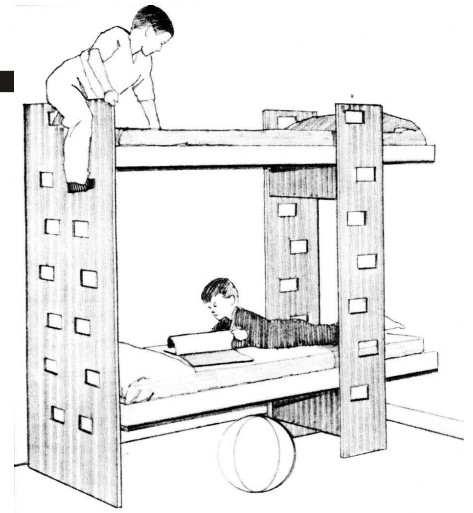

## **MATERIALS LIST**

1 piece ½" x 3' x 6', 1 piece ½" x 4' x 6',  
1 piece ½" x 4' x 7' CANPLY EXTERIOR  
Good Two Sides grade fir plywood  
2" x 2" x 11' lumber (bunk cleats)  
2" x 4" x 40' lumber (bunk rails)  
4, 1" x 4" corner braces  
14, 3/16" x 4" carriage bolts and wing nuts  
8, 3/16" x 1" stove bolts and wing nuts  
4 furniture glides  
1 ½" No., 8 flat head wood screws  
Glue  
Wood Filler  
Sandpaper  
Paint or stain

## **HOW TO BUY PLYWOOD**

In the bill of materials, CANPLY EXTERIOR fir plywood with two faces of highest appearance (Good Two Sides grade) is specified where both sides of the panel will be seen in the finished job. Faces of the grade, which may contain carefully made repairs, are smooth and easy to paint. Select plywood with uniform grain pattern and colouration if you intend to use a light stain finish. Where only one side of the panel will be seen once the project is completed, Good One Side grade is specified for economy.

Medium Density Overlaid (MDO) plywood (plywood with a resin impregnated fibre overlay) may be used as an alternative to Good Two Sides when an extremely high quality paint finish is desired. MDO plywood is not suitable for a stain finish.

## **CANPLY EXTERIOR FIR PLYWOOD**

Douglas fir plywood stamped CANPLY EXTERIOR is made by member mills of the Canadian Plywood Association. It is bonded with 100% waterproof glue and may be used indoors or out. Look for the edgemark CANPLY EXTERIOR on every piece of plywood you buy.

## HOW TO WORK WITH FIR PLYWOOD

CANPLY EXTERIOR fir plywood is manufactured in large-sized (4' x 8') panels which simplify every building step for you. Laying out the parts for cutting is the only step required before starting actual construction. Be sure to allow for saw kerfs between adjacent pieces.

### Sawing

Use an 8 to 10 pct. cross-cut for handsawing. Support panel firmly with good face up. For curves use a fine-toothed coping saw. For inside cuts, start hole with a drill; then use coping or keyhole saw. For power sawing, a combination blade gives best results. With first cuts, reduce panel to pieces small enough for easy handling. Use of scrap lumber underneath panel prevents splintering on back. Plan to cut matching parts with same saw setting. Curved cuts may be made with jigsaw, bandsaw or sabre saw.

### Drilling

Support plywood firmly. For larger holes use brace and bit. When point appears through plywood, reverse and complete hole from back. When drilling, finish slowly to avoid splintering.

### Planing

Remember, edge grain of plywood runs in alternate directions so plane from ends toward centre. Use shallow-set blade.

### Sanding

CANPLY EXTERIOR fir plywood is sanded smooth in manufacture- a big time saver- so minimum surface sanding is necessary. Most sanding should be confined to panel edges. Use 80 for finer sandpaper before sealer or flat undercoat is applied. After sealing, use 120 sandpaper in direction of grain only.

### Gluing

Glue may be used on panel edges and faces. Apply glue to clean surfaces. Press firmly together until "bead" appears. Maintain pressure with clamps, nails or screws to allow glue to set. For exterior exposure use resorcinol type waterproof glues. Gluing is recommended for strongest, permanent fastening.

### Nailing

Nail size is determined by the thickness of plywood used, as follows:

Plywood Thickness	Nail Size
1/4" and 3/8"	1 1/2" casing or finishing
1/2"	1 1/2" or 2" casing or finishing
5/8" and 3/4"	2" casing or finishing

Substitute casing for finishing nails wherever a heavier nail is needed. For exterior work always use corrosion-resistant nails.

## Other Fastenings

Screws, bolts and other special fastenings may be used. Always pre-drill for screws and bolts (see "DRILLING" above). Minimum screw sizes as follows:

Plywood Thickness	Screw Size
1/4"	3/4" No. 4
3/8"	1" No. 6
1/2"	1 1/4" No. 6
5/8"	1 1/4" No. 8
3/4"	1 1/2" No. 8

## HOW TO FINISH FIR PLYWOOD

For best results always use quality finishes, following the manufacturer's instructions. Whenever practicable, fill the plywood edge grain before painting. Natural finishes do not withstand weathering and are not recommended for plywood outdoors.

### EXTERIOR FINISHING

#### Paint

Prime the panels carefully, front and back, with oil-base house paint undercoat. See that the prime and subsequent coats seal the edge grain. A three-coat finish with an intermediate coat of primer mixed half-and-half with finish colour will look best. For the final coat apply the paint as it comes from the can.

When painting plywood doors, give the front and back the same number of coats.

Choose bright-coloured exterior sash and trim enamel for a high-gloss finish on toys, patio furnishings, etc.

#### Stain

Stain finishes are available which have considerable hiding power but do not conceal the texture of the plywood grain. Creosote base stains penetrate deep into the plywood producing rich lively colours that enhance grain beauty. Both creosote and non-creosote stains are highly recommended for exterior finishing of CANPLY EXTERIOR fir plywood. Apply according to manufacturer's directions.

### INTERIOR FINISHING

When it comes to finishing indoor projects, give your own taste full sway. Fir plywood can be painted to harmonize with your decorative theme, or stained to bring out the full beauty of the wood grain.

Extra care in surface preparation and application will give you a more attractive and durable finish. Clean all surfaces perfectly and fill nail holes and blemishes with wood filler. Sand lightly between coats.

## Paint or Enamel

Conventional wall and woodwork paints and enamels may be used. (For surfaces which will be cleaned frequently, use washable paints for enamels.) First, brush on flat paint or enamel undercoat. Thin if desired. Second, apply second coat of undercoat, tinted to shade of finish coat. (Note: For gloss finish mix equal parts flat undercoat and gloss enamel for second coat.) Third, apply final coat as it comes from can. (A two-step finish without second undercoat may also be used.)

Interesting textured surfaces may be obtained by priming as above, followed by heavy coat of stippling paint. Use brush, roller or sponge to texture. When using water-thinned paint, first seal plywood with clear resin sealer, shellac or flat white oil paint. Then paint according to directions on can for a sealed surface.

## Natural Finishes

For an easy, inexpensive "blond" finish, first apply coat of interior white undercoat thinned so grain pattern shows through. (Tint if you desire colour.) Second, apply clear shellac, flat varnish or lacquer.

Attractive and economical one-coat stain-waxes are also available in various colours. If you prefer a dark stain, first apply coat of clear resin sealer to subdue grain contrast.

Here's a four step system you can use to get a luxurious light stain glaze: First apply white undercoat thinned with equal parts of turpentine or paint thinner. Wipe or dry-brush for more grain show through. Second, apply one coat thinned white shellac or clear resin sealer. Third, to provide colour apply interior undercoat or enamel thinned as in step one. Choose any colour you want for this coat. Wipe or dry-brush to proper colour tone. Fourth, one coat flat varnish. Steel wool for added luster.

## Easy Step-By-Step Instructions

1. Lay out parts on plywood panels as shown. Allow for saw kerfs between parts.

2. Cut plywood parts to exact size. Cut-outs are made by drilling holes at the inside of each corner and removing material with a sabre saw or keyhole saw.

3. Next, cut all bunk rails and cleats to proper length. Make a  $\frac{1}{2}$ " dado on all inside rails  $1\frac{1}{2}$ " from the top edge. Then rip foot rails only to a width of 2" and notch side rails for 2" x 2" cleats as show in detail 1.

4. Glue and nail dadoed side rails to end rails and bottom "E". Drill matching holes for  $\frac{3}{16}$ " bolts in 2"x2" cleats on uprights and fasten with glue and  $1\frac{1}{2}$ ", No. 8 wood screws.

5. Bolt uprights to bed rails for trial assembly. Install 4" corner braces on 2"x2" cleats with screws as shown. Position plywood stiffeners and drill holes for  $\frac{3}{16}$ " stove bolts through 4" corner braces.

6. Disassemble and round off all corners and sharp edges with a block plane, rasp, and sandpaper. Fill screw holes and plywood edges with wood filler. Attach furniture glides and complete final sanding and painting.

### CONSTRUCTION DETAILS

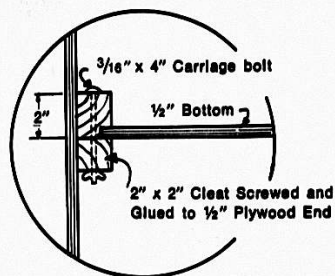

TYPICAL CONNECTION DETAIL 1

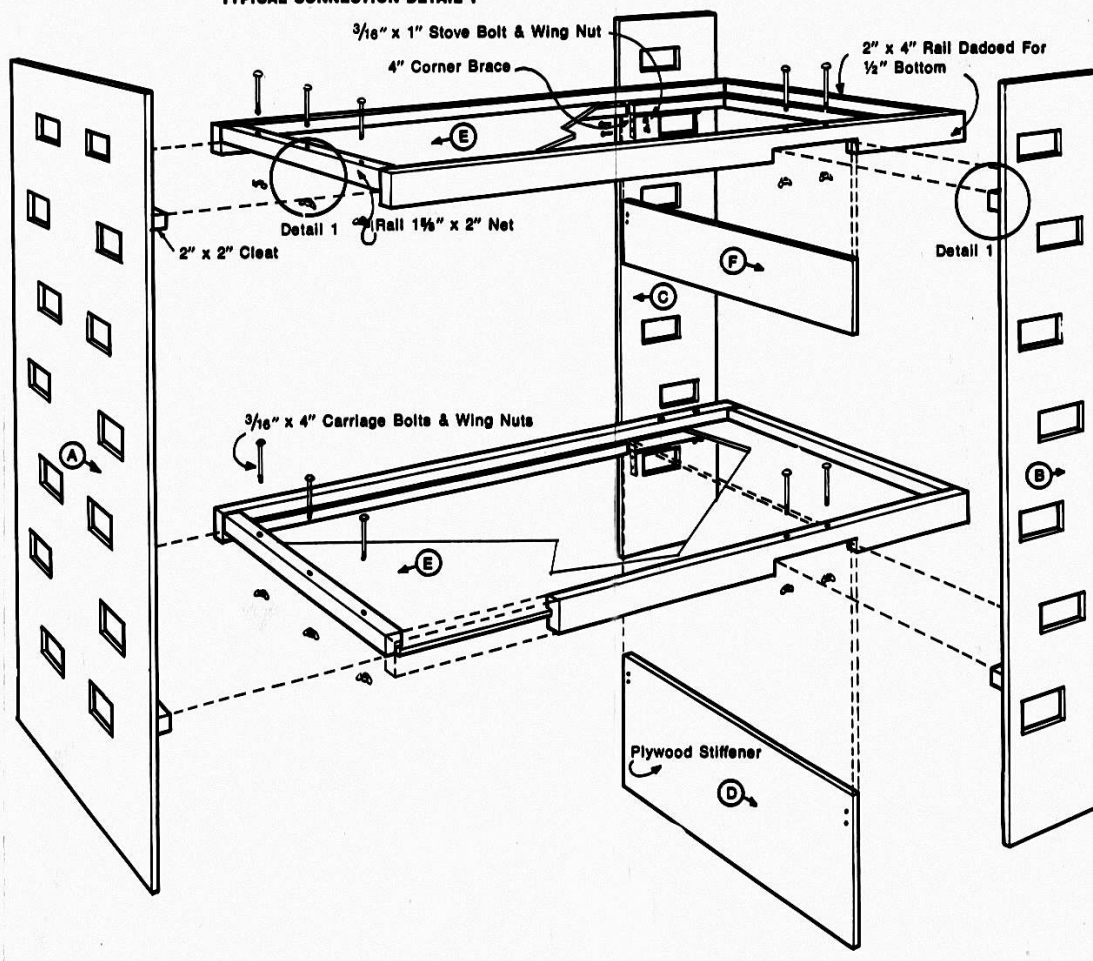

# CUTTING DIAGRAMS

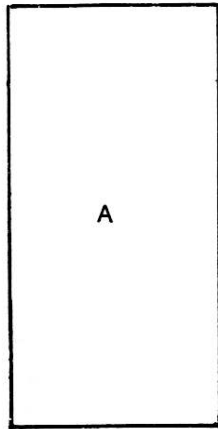

1/2" x 3'-0" x 6'-0"

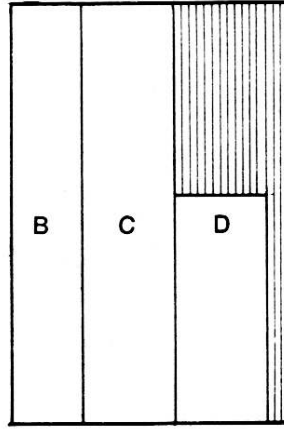

1/2" x 4'-0" x 6'-0"

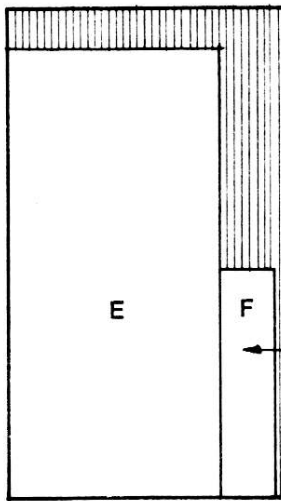

CUT ONE ONLY

1/2" x 4'-0" x 7'-0"

## PARTS SCHEDULE

CODE	NO. REQ'D	SIZE	PART IDENTIFICATION
A	1	36" x 72"	Foot Support
B	1	12" x 72"	Head Support
C	1	16" x 72"	Head Support
D	1	16" x 39 1/4"	Lower Stiffener
E	2	37" x 77"	Bunk Bottom
F	1	9 5/8" x 39 1/4"	Upper Stiffener

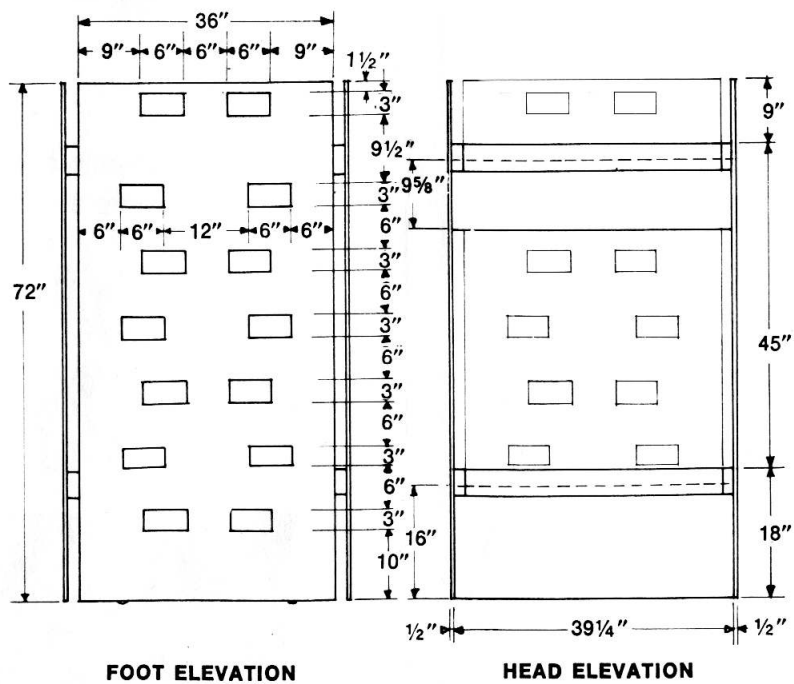
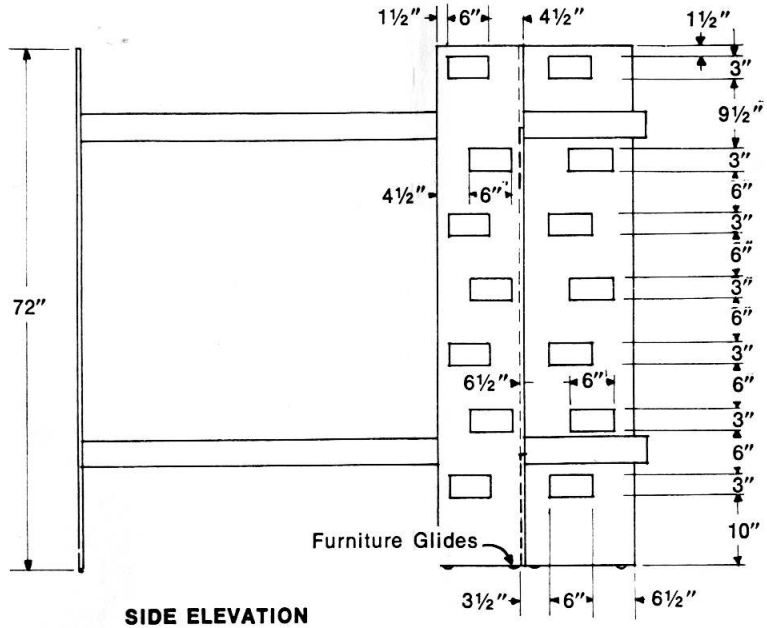
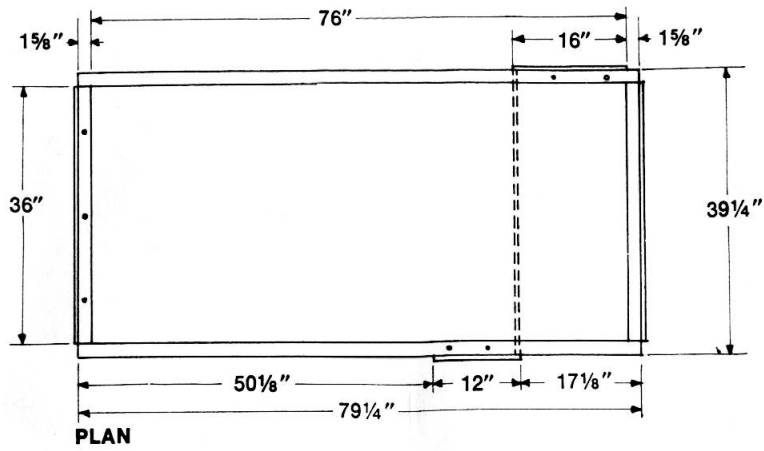

Although every effort has been made to ensure that all data in this Ply\*Plan are accurate, CANPLY shall not be responsible for injury, damage or loss, however caused, arising from the use of information contained herein.