

136

PLYWOOD DESK

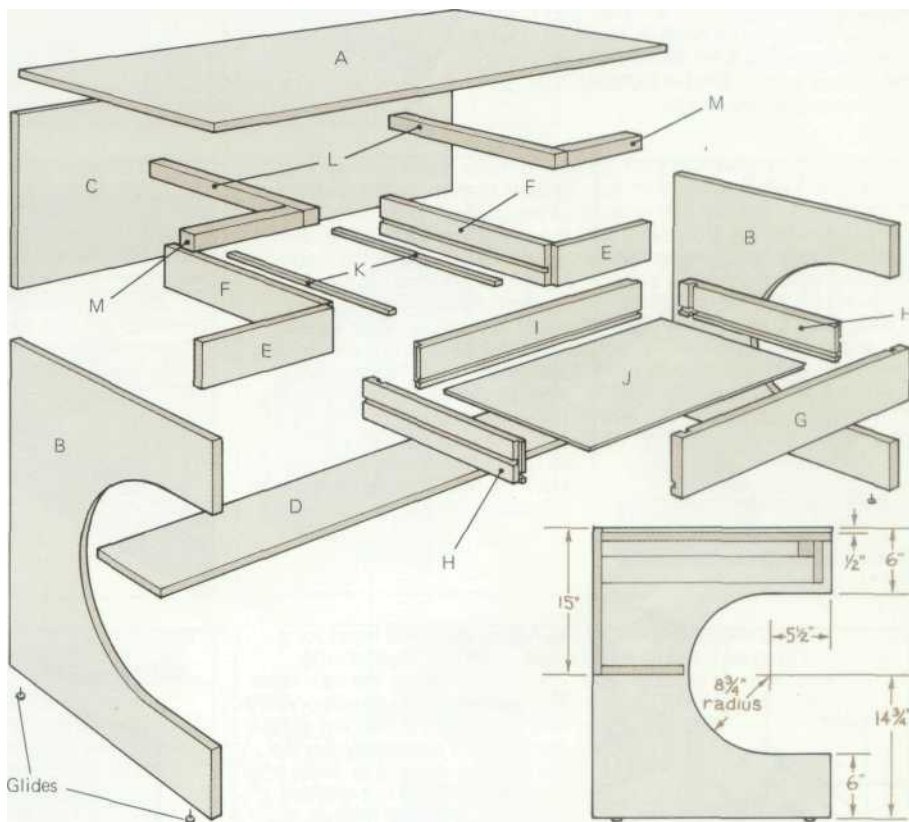

Simple in design and inexpensive, this plywood desk is made from a single 4-x 8-foot panel. Plywood is available with many hardwood veneers; it can also be covered with plastic laminate, which is well suited for a work surface. Since you have many options for the materials and colors of the desk, you could use one wood veneer or one laminate throughout, mix wood veneers, or mix a wood veneer and plastic

When you cut plywood with a power saw, the better side of the wood must be kept face down so that it does not splinter as the teeth of the saw pass through it. If you use a handsaw, whose teeth cut on the downward stroke, cut the wood with the good side facing up.

When the desk is completed, cover the exposed edges of the plywood with strips of the same laminate or veneer that covers the faces of the panels.

Parts list						
Part	Name	Quantity	Thickness	Width	Length	Material
A	Top	1	3/4"	23 3/8"	48"	Plywood
B	Side	2	3/4"	23 15/16"	29 1/2"	Plywood
C	Back	1	3/4"	15"	48"	Plywood
D	Shelf	1	3/4"	8"	48"	Plywood
E	Front	2	3/4"	4"	12"	Plywood
F	Drawer support	2	3/4"	4"	21 3/8"	Plywood
G	Drawer front	1	3/4"	4"	23 3/8"	Plywood
H	Drawer side	2	3/4"	3 1/4"	23"	Plywood
I	Drawer back	1	3/4"	3 1/4"	21 3/4"	Plywood
J	Drawer bottom	1	1/8"	21 1/2"	21 3/4"	Masonite
K	Drawer slide	2	1/2"	3/4"	23 3/8"	Maple (or any hardwood)
L	Drawer glue block	2	1 1/2"	1 1/2"	21 3/8"	Maple (or any hardwood)
M	Front glue block	2	1 1/2"	1 1/2"	10 1/4"	Maple (or any hardwood)

Tools and materials: Radial arm saw with a dado head and a fine-tooth blade Saber saw Electric drill with 2" Screwmate drill bit. Steel tape rule, combination square, pencil. Clamps. Screwdriver, hammer, rubber

roller. Sanding block, No. 100 sandpaper Wood glue, contact cement A candle stub Veneer tape 3/4" wide. Wood (see above) Four nail-in metal or plastic glides Four doz 2" No. 10 flathead wood screws.

You can cut all plywood pieces required for this project from a standard 4- x 8-ft. panel of 3/4-in. plywood Use a steel tape rule to measure off the widths of parts A, B, C, D, E, F, H, and I across the plywood panel Be sure to add the kerf (the thickness of the cut made by your saw blade) to each measurement Make a short test cut in the upper right-hand corner of the panel and measure its width (Or measure, mark, and cut one piece at a time, using the dimensions in the chart on page 49, and always cut just outside the pencil line on the plywood.) Use the framing square to draw cutting lines across the plywood. Measure off the lengths of parts B, E, F, G, H, and I, and use the square to mark off their edges Use a compass, yardstick, or string and nail to draw the circular part of B Use a saber saw for the curves

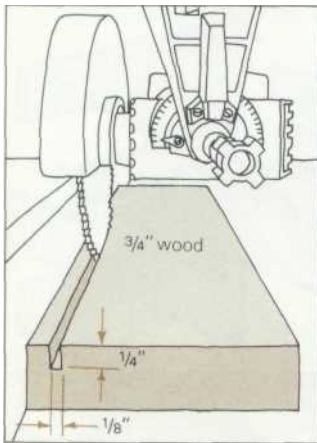
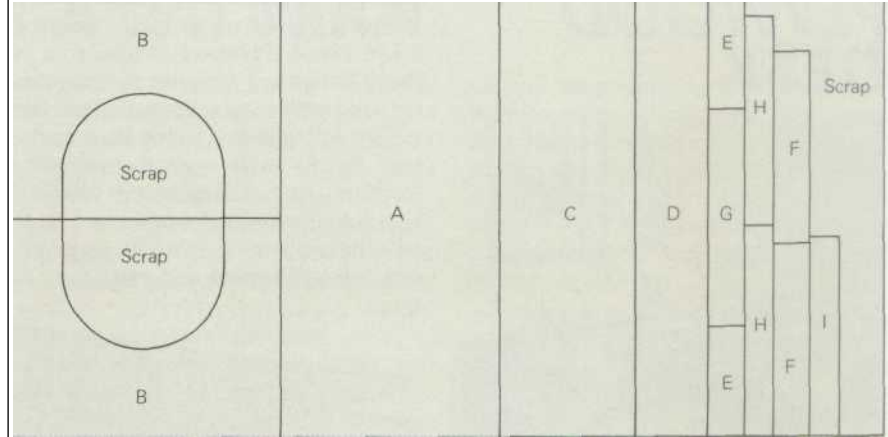

1. To make dado cuts for the drawer bottom on the four sides of the drawer (G, H, and I), fit the radial arm saw with a 1/8-in. dado head Position the dado head 1/2 in. above the saw table Cut through a piece of scrap wood 3/4 thick, then measure the cut, it should be 1/8 in. wide and 1/4 in. deep Make adjustments, if necessary, until part J fits snugly into the cut Then cut dados along the length of the drawer sides (H), back (I), and front (G) 1/4 in. from the bottom edges of each part

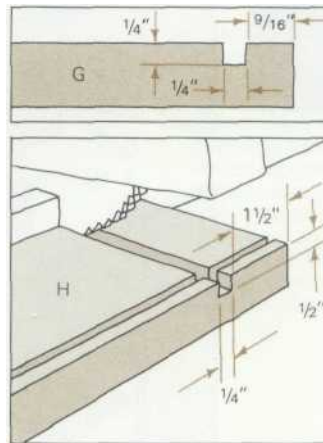

4. Set the dado head to make a 1/4-in.-wide cut and raise it to 1/2 in. above the saw table Cut through a piece of 3/4-in. scrap wood If the tongues you made in Step 3 do not fit snugly into this dado, adjust the saw to make a dado that will fit snugly Then cut two vertical dados on the inner face of the drawer front (G) 9/16 in. from each end Also cut one vertical dado 1/4 in. wide and 1/2 in. deep on the inner face of each drawer side (H) 1 1/2 in. from the back ends

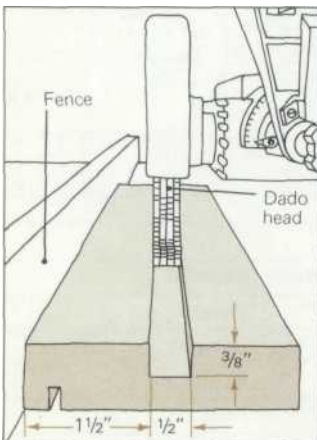

2. Adjust the dado head for a 1/2-in.-wide cut. Position the blade 3/8 in. above the saw table Cut another piece of scrap wood and measure the cut, adjusting the blade, if necessary, so that the cut is exactly 1/2 in. wide and 3/8 in. deep Then cut dados along the length of the two drawer sides (H) on the faces opposite the 1/8-in. dados cut in Step 1, positioned 1 1/2 in. from the lower edges. Make identical cuts on the inner faces of the drawer supports (F)

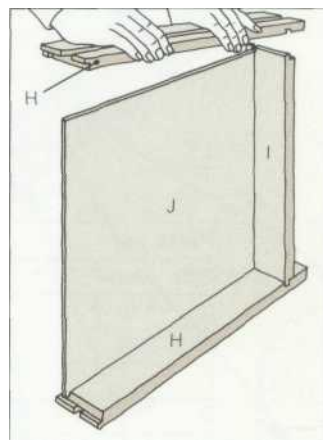

5. To check that the drawer assembly fits snugly, slip together one side and the back and slide in the bottom (J) Then add the other side and the front If they do not fit snugly, make adjustments before you go any further Sand dados that are too tight; discard parts that are too loose and cut replacements When everything fits properly, pull the pieces apart and reassemble them in the same sequence, this time gluing all joints as you go

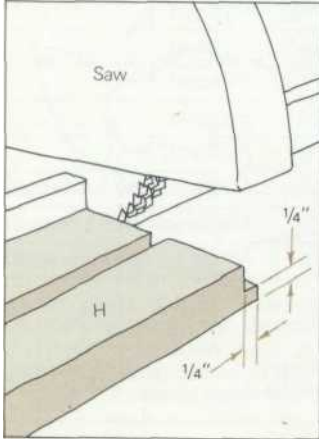

3. Cutting away a section 1/4 in. wide and 1/2 in. deep from the front ends of the drawer sides (H) and both ends of the drawer back (I) will create tongues 1/4 in thick. To do so, lower the dado head to 1/4 in above the table. Make a mark 1/4 in. from each end of I and from the front ends of parts H. Lay each drawer side flat on the table with the 1/8-in. dadoes you have already cut facing down; then cut away the 1/4 in. between your marks and the ends of the parts. Lay the drawer back on the table, its Win. dado facing down, and cut 1/4-in. sections from both ends, making two tongues.

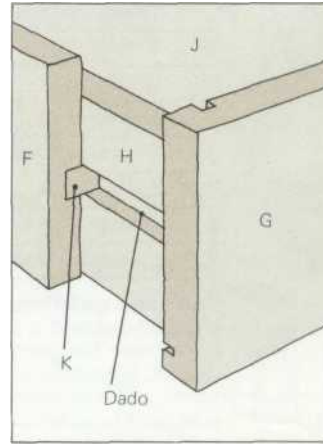

6. Fit the hardwood slides (K) into the dadoes in the drawer supports (F). They should fit snugly. If they are too tight, sand the dadoes. If they are too loose cut new slides. When the slides fit properly, glue them in place. After the glue dries, place the supports beside the drawer to see if the drawer sits well on the slides and can move easily along them; if not, sand down the slides. Rub a candle over the slides and along the dadoes to lubricate them.

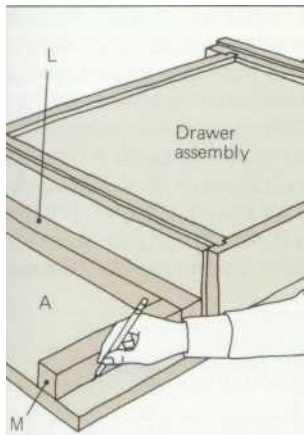

7. Place the desk top (A) upside down. Place the supports and slides into the sides of the drawer, leaving a slight clearance on each side, then position this assembly carefully on the desk top. Place two glue blocks (L) beside the supports, and place the other blocks (M) perpendicular to them. Mark the positions of the four glue blocks carefully on the desk top.

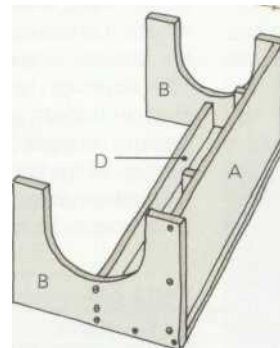

11. Prop the desk top (A) between the sides so that its top surface is vertical and 1/2 in. below the top edges of the back and sides. Drill three holes through each side and into the top, using the Screwmate bit. Attach the top with six screws. Turn the desk upright and drill six more holes through the back of the desk and into the top, and insert screws. Put the shelf (D) in place, its bottom flush with the bottom edge of the back, and attach it to the sides in the same way as the top, using two screws on each end and six along the back.

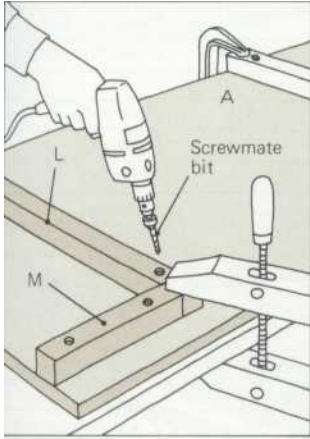

8. Remove the drawer and supports from the desk top. Align the glue blocks on the marks you just drew. Use a 2-in No 10 Screwmate bit to drill countersink, clearance, and pilot holes simultaneously through each block and into the desk top. Drill holes for two screws into each glue block about 2 in. from each end.

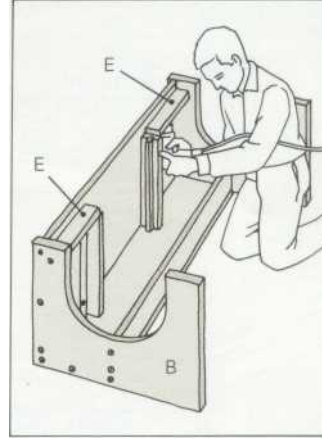

12. Put the fronts (E) in place so that they rest against the glue blocks (M) and the sides (B) of the desk. Use the Screwmate bit to drill a hole through each side into the centers of the edges of the front pieces. Drill one hole through the center of each glue block (M) into each front piece. Place glue on the outside edges of the front pieces and over the faces of the glue blocks. Insert 2-in. screws into pilot holes.

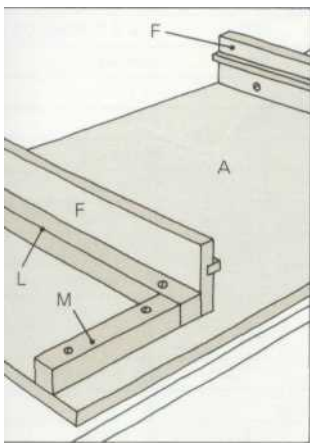

9. Spread glue on the bottom of each block, then screw all four of them to the desk top with 2-in. No. 10 flathead wood screws. Put the drawer supports (F) in place beside the glue blocks. Use the Screwmate bit to drill holes through each drawer support into the glue blocks about 4 in from each end.



13. Turn the desk onto its top, and hammer two glides into the bottom edge of each side (B) about 3 in from the front and back corners.

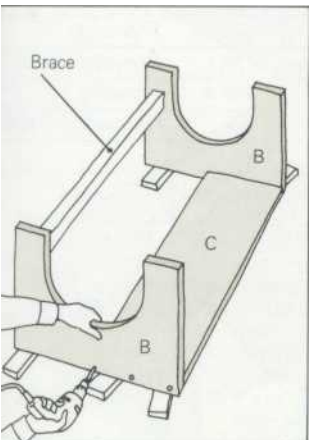

10. Lay the desk sides (B) on their back edges (so the U's face upward) with the back (C) between them. Align the edges and corners, and prop up the sides so they are perpendicular to the back, then nail a temporary brace between the sides. Drill three holes through each side into the back, using the Screwmate bit. Apply glue to the edges of the back and assemble the parts with 2-in screws. Remove brace.

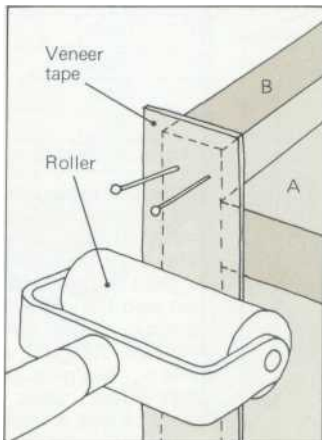

14. Cover the cut edges of the plywood wherever they are exposed with 3/4-in. veneer tape that matches the faces of the plywood. Measure the exposed edges, cut strips of tape to the proper length, cover them with contact cement, and let cement become tacky. Carefully position the tape and press it in place with a rubber roller. If necessary, sand the tape down to the width of the plywood with No. 100 paper. Be careful not to damage the veneer on the faces of the plywood. Stain and finish the veneer.