

170
RECIPE BOX



This recipe box can hold more than recipe cards—buttons, address cards, candy, crayons, almost any little thing around the house can find a home in it.

1. If you are unable to purchase the 1/2" stock needed for the recipe box, custom plane the necessary amount of 3/4" stock or resaw it on a bandsaw.

2. Cut the basic box parts (A, B, C, D, E) to the dimensions found in the materials list with the grain running the way indicated in the drawings. Rip a 70° bevel on the upper edges of the front, back, and top pieces and make 70° angled cuts across the upper ends of the sides.

3. Make a simple jig to hold the top and back pieces at a 70° angle while you make the cutouts for the hinge. The jig consists of a 2 x 4 with a beveled front face (see the jig layout end view) that is fastened to a table saw miter gauge with counterbored carriage bolts and wing nuts. The jig must be long enough to be used on either side of the saw blade. (A 12" length should suffice for most saws.)

4. Cut the notches on the top and back pieces with your saw blade (or dado blades, if you have them) set to a height of 9/16". Hold each piece firmly against the jig and keep its beveled edge flush with the table top while cutting. Make the notch at the center of the top piece wide enough to create 1/64" of clearance on either side where the two pieces fit together.

Fit the top and back pieces together with their faces flush and a 1/16"-thick spacer holding them slightly apart. Center and drill 1/4"-diameter holes through each wing of the top piece 1" deep into the adjacent part of the back piece. This process is best done with a horizontal boring machine while the pieces are held flat on a table top and against a fence.

6. Cut a 1/2" radius on the hinge sections of the top and back. Sand one end of each dowel so that it will rotate easily when fit inside the back.

6. Dry assemble the top and back to make sure the dowels fit and the hinge operates properly. Sand parts as needed.

7. If desired, cut a scallop in the inside edge of the front to make it easier to get to the front cards.

8. Glue the box together without the top. Keep excess glue off the visible parts and clamp until the glue dries.

10. Set the top in place lining up its dowel holes with those of the back. Push the dowels through the holes

in the top until they barely penetrate the back. Apply glue on the last 3/4" of each dowel, then push them the rest of the way in until they are flush with the sides of the top.

11. Give the box a final touch up with sandpaper, then finish as desired. Attach the knob and mount felt pads on the upper edge of the front.

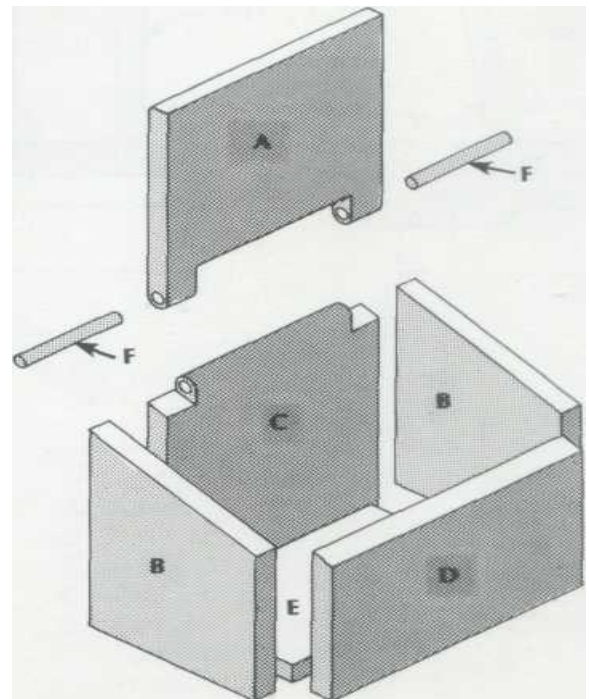

DENOTES GRAIN DIRECTION



NOTE: ALL STOCK 1/2"

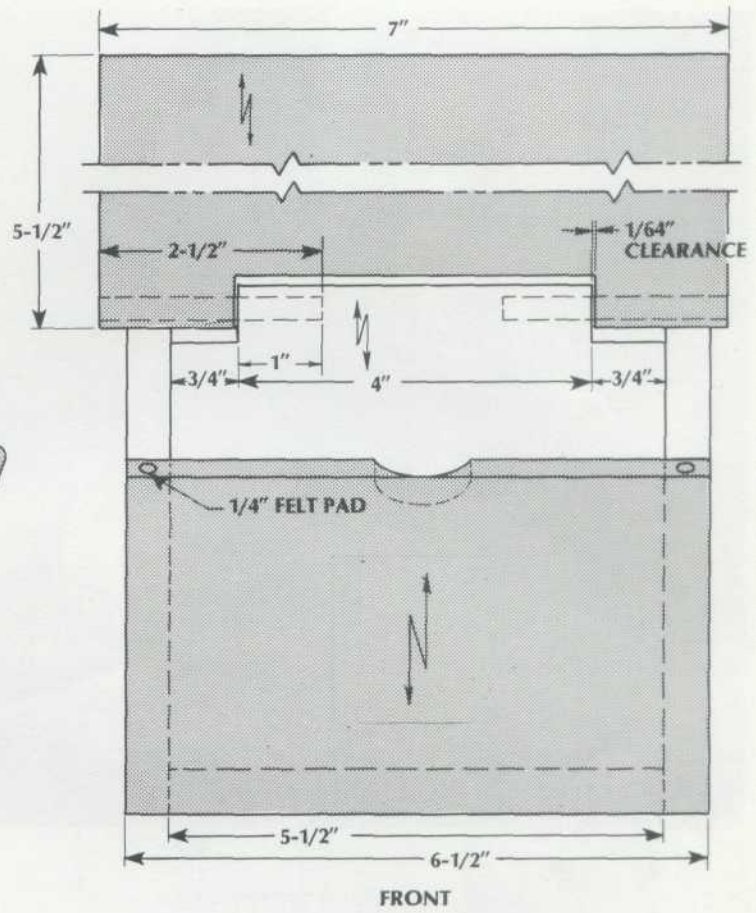
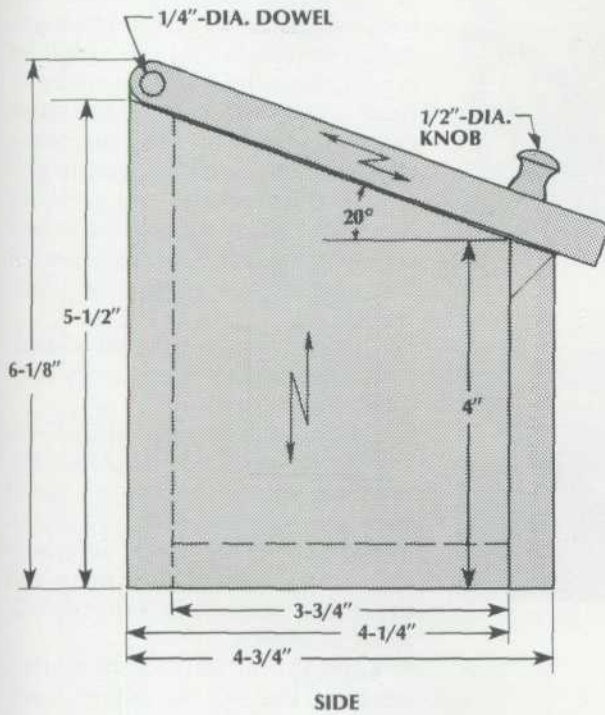

LIST OF MATERIALS

(finished dimensions in inches)

| | |
|---------------------|---------------------|
| A Top | 1/2 × 7 × 5-1/2 |
| B Sides (2) | 1/2 × 4-1/4 × 5-1/2 |
| C Back | 1/2 × 5-1/2 × 6-1/8 |
| D Front | 1/2 × 6-1/2 × 4 |
| E Bottom | 1/2 × 3-3/4 × 5-1/2 |
| F Dowels (2) | 1/4 dia. × 2-1/2 |
| Felt pad (2) | |
| Knob (optional) | |
| Carriage bolts | |
| Wing nuts | |
| Wood glue | |

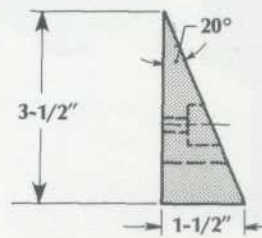
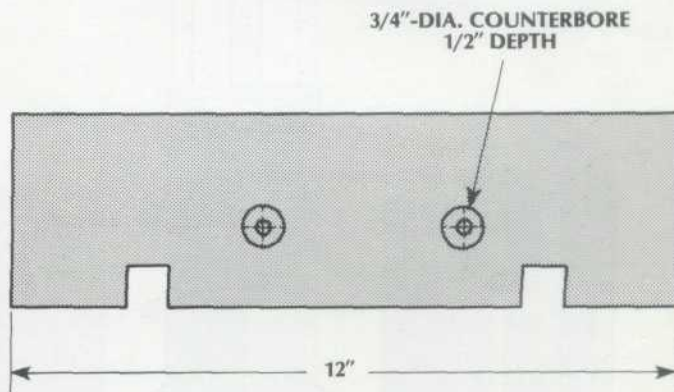

SAWING JIG LAYOUT