

Door & Look-Down Computer Desk

1. Introduction

When excess computer use starts to give you discomfort, one thing you need is a simple, inexpensive desk that will help you address the problem now. This is just such a desk and can be build in one weekend for less than \$200.

It is a variation on the simple form of the Door & Filing Cabinet desk that is low-stress. This design is simple to build so that anyone with simple home repair skills and tools -- yes that means you -- can make a good, low-stress desk quickly. This fourth version can be made in any length form 60 to 80 inches, it has simple-to-make legs so you have lots of leg room, a solid fixed keyboard shelf, and a optional well for the monitor.

The optional look-down feature lets you set your monitor down into the desk. This feature is very popular with people who have neck and upper back discomfort or wear tri-focal glasses.

2. Sketches

1. Door & Look-Down Computer Desk

At the start of this note is a drawing of the fourth version of this desk. It shows the front and the underside of the door with wooden blocks, the keyboard shelf, and optional monitor cut out. A simple set of legs instead of a second filing cabinet so that you can trim the door to any length to fit your room and giving you more room for your legs.

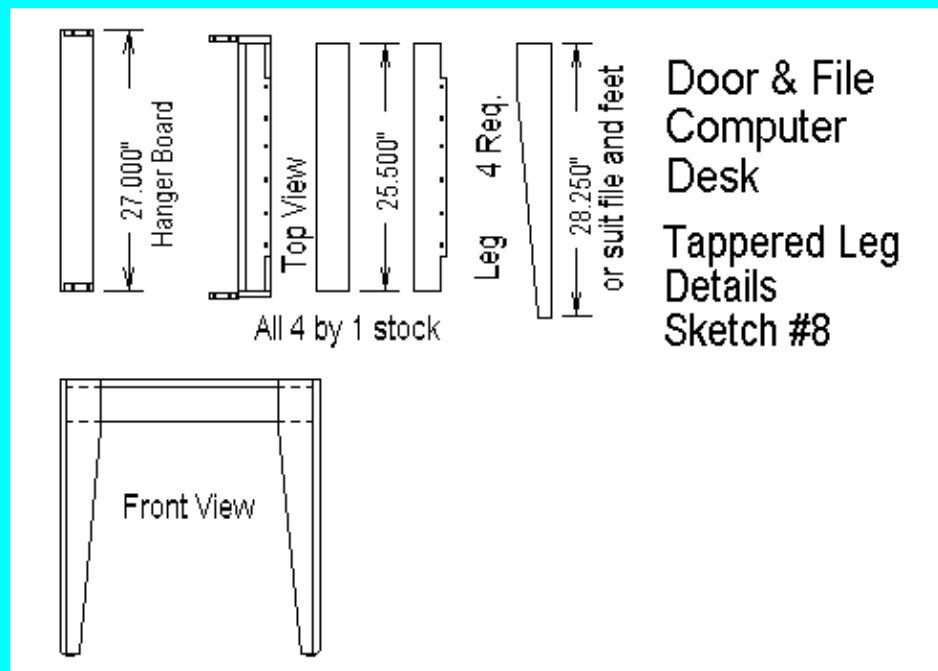

2. Tapered Leg Details, Sketch #8

This sketch show the parts to build the legs. All the parts are easily cut from 1 by 4 stock.

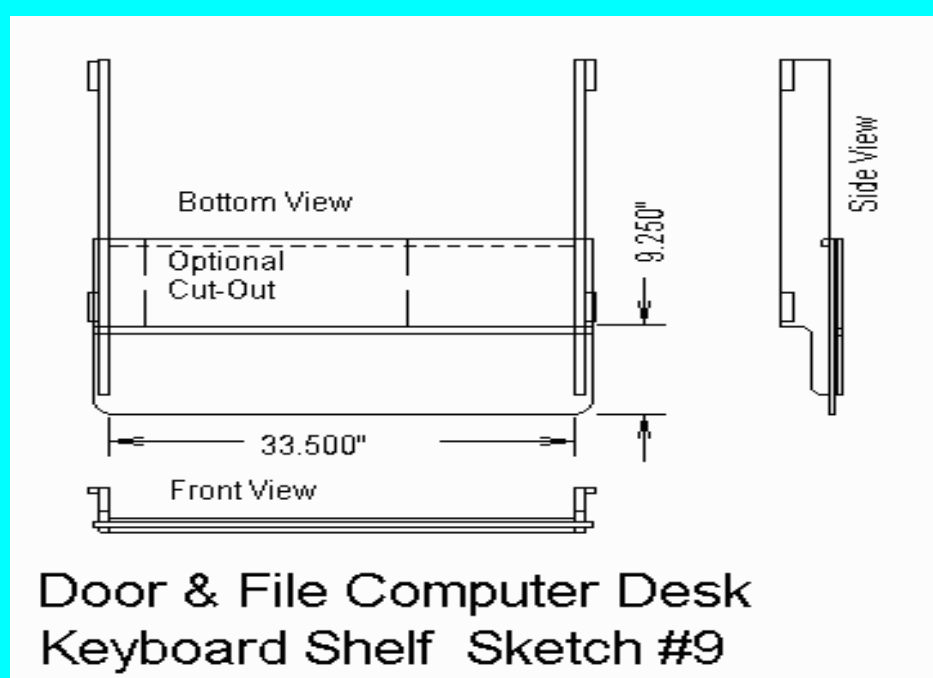

3. Keyboard Shelf, Sketch #9

The keyboard shelf is large enough for an ergonomic keyboard with the mouse pad beside it. It is a simple to build and is hung below the desk top.

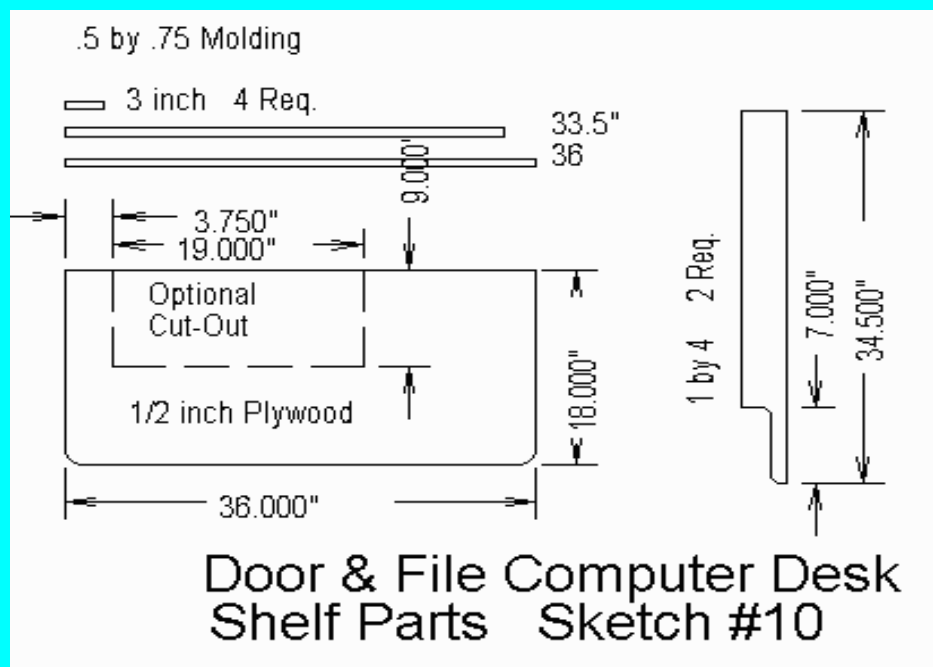

4. Shelf Parts, Sketch #10

This sketch shows details of the construction of the keyboard shelf. It is simply made from 1-by-4's, 5. by .75 inch molding and plywood. The optional cut-out is for the look-down feature.

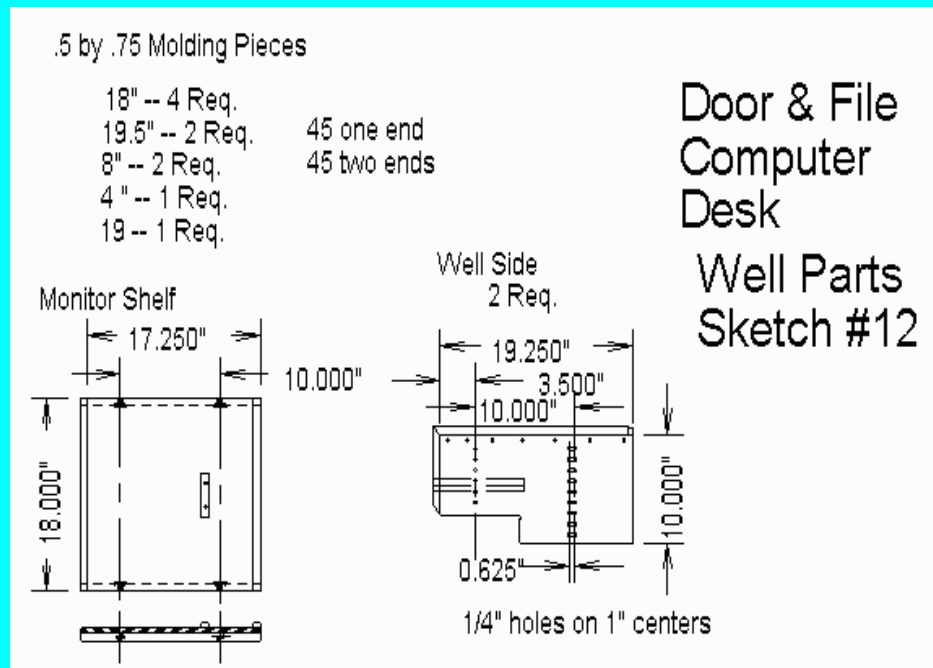

5. Well Parts, Sketch #12

This sketch shows details of the construction of the monitor Well for the look-down feature. The parts are made from 1/2 inch plywood and .5 by .75 inch molding. The Monitor Shelf has "T" nuts to fasten it to the Well Sides. The Well Sides are drilled with three lines of 1/4 inch holes on 1 inch centers. The back two rows of holes are connected into a slot. This lets you bolt the Monitor Shelf in place at a wide variety of heights and angles.

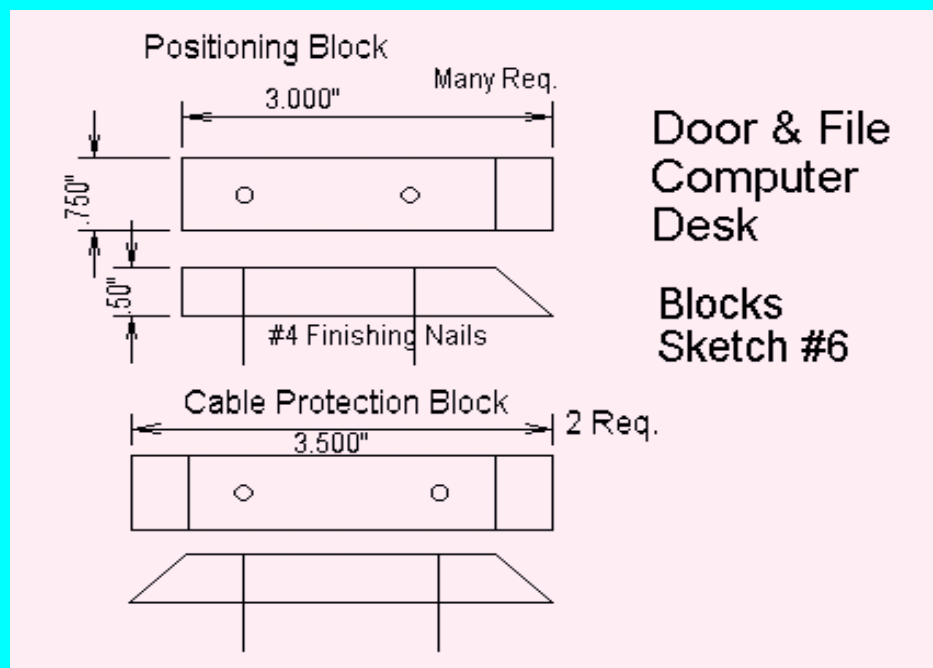

6. Blocks, Sketch #6

The blocks are cut from .5 by .75 inch rectangular molding with a hand miter box. Six Positioning Blocks are needed for this desk.

3. **Materials**

You can build this desk with the following inexpensive materials:

1. **Wood**

- Solid Core Door, 80 by 28 inches, 1 -- \$ 44.00
- .5 by .75 inch wooden Molding, 26 feet, \$.32/foot -- \$ 10.00
- 1 by 4 pine boards, \$.65/foot -- \$ 20.00
- 1/2 inch plywood, 4 by 8 foot sheet, AC -- \$ 21.00

2. **Cabinet**

- Two Drawer Filing Cabinet, 1 -- \$ 50.00

3. **Hardware**

- 4 d finishing nails, 1 pound -- \$ 1.50
- 1-1/4 inch #8 flat head screws, 100 -- \$ 3.50
- 5/8 inch brads, 1 box -- \$ 1.50
- 3 inch angle braces, 2 -- \$ 3.50
- Feet, set of 4 -- \$3.00
- Eye Screws, package -- \$.75
- 3/4 inch #6 pan head screws, 8 -- \$.75
- 1/4 inch "T" nuts, 4 -- \$.75
- 1/4 inch bolt, 1-1/4 inches long, 4 -- \$.50
- 1/4 inch flat washer, 4 -- \$.25
- 1/4 inch fender washers, 4 -- \$.75

4. **Other Materials**

- Wood Glue 8 oz. -- \$ 3.00
- Stain -- \$ 8.00
- Polyurethane Varnish -- \$ 9.00

5. **Omissions and Contingencies**

- Allow %15 for tax, sandpaper etc. -- \$ 18.25

6. **Total -- \$ 200.00**

The secret is to get a good price on the filling cabinet.

4. **Tools Required**

You will need the following tools:

1. **Power Saw**

A circular or jig saw speeds with a plywood blade the work. Hand saws can be used.

2. **Saw and Miter Box**

A small hand saw and miter box are needed. The cost new is about \$20.00.

3. **Drill**

This can be a hand drill or a small power drill. You can use cut off nails for the bits. A #8 screwmate drill bit helps a lot.

4. **Screw Driver**

The angle brackets and drawer guides usually have Phillips head screws.

5. **Hammer**

You need a common claw hammer. A small point nail set also helps.

6. **Square**

You need a simple square.

5. **Construction Notes**

1. **Getting Filling Cabinet**

Two draw filling cabinets are valued and rarely found at garage sales. Decent new ones cost about \$50.00 at a discount store. Cheap cardboard ones do not work well, neither do a real cheap metal ones without wheeled drawer guides.

It is possible to cut off 4 drawer filing cabinets but this is difficult and usually sloppy.

2. Floor Space

Determine how much floor space you have for this desk. It is easiest to leave the door just as you buy it at 80 inches. If you have to cut it down much below the 60 inches shown then you will not have room for a large keyboard and mouse pad together.

3. Buying the Door

The door normally used for this type of desk are "Hollow Core". They are inexpensive and light weight but they only have solid wood around the outside edge. The center cavity of the door is fill of air and cardboard. You can only get nails and screws to grab around the outside edge.

The alternative is a "Solid Core" door. These cost about \$20.00 more and much heavier. The sawn edge will be filled but may have gaps.

If your are implementing the Look-Down feature then you will need a "Solid Core" door. They have enough strength even with the large cut-out section.

You can also get these doors either covered in inexpensive hardwood or masonite. The hardwood is bland but looks nice if stained and varnished.

4. Cutting the Door to Length

If you need a desk shorter than the full length of door, you can is cut it off and fill in the hollow core area with a piece of 1-by stock. The cut must be square. A solid core door will not take a fill board but the edge may have small voids and be difficult to finish nicely.

You can often have this cut made at the lumber yard for a modest price. You must know the exact length you need before you buy the door.

At home this cut is best done with a power saw running against a straight edge. You must use a plywood blade with many teeth. The blade should just come through the door. To reduce splintering try placing masking take on both sides of the door, then marking on it,

and cutting through the tape.

The central area of a hollow core door must be filled with a piece of 1-by lumber cut to fit. Hold it place in with glue and a few nails from the bottom.

5. Lay Out

Place the door on the floor best side down. Be sure to protect it by placing in on a clean rug or magazines. Anything trapped under the door will leave an ugly scratch.

Place the empty filing cabinet in place upside down on the door. Position it equal distance front to back and one inch from the cut end.

Place your monitor one the door leaving adequate space between your leg and the filing cabinet while your are seated directly in front of the monitor. Rubbing your leg against the cabinet is a real nuisance.

Place your keyboard in front of the monitor with the space between the "6" and "7" keys centered on the monitor.

Lay a piece of 1-by-4 across the end of the door to represent the legs.

When you have everything where you want it, mark the center of the monitor. Measure over toward the cabinet 8.5 inches for the edge of the monitor cut-out and over 11.75 inches for the outside of the shelf support. The other edge of the Monitor Cut-Out is 19 inches over from the first and the other shelf support 35 inches over from its first. Also mark the position of the legs.

6. Cut-Out

The monitor cut-out is best done with a circular or jig saw running against a clamped straight edge. You will have to finish the cuts with a hand saw.

7. Cutting the Molding

You use .5 by .75 inch molding to position the filing cabinets, keep the desk top from crushing the cable against the wall, and to frame the drawer. It is commonly available as it is used in sash windows.

The molding is easiest cut with a miter box and small hand saw. These cost about \$10.00 each new. All the cuts are either 90 degree or 45 degree. Be careful to note if the 45

degree cuts are on the .5 inch or the .75 inch side.

8. Positioning Blocks

The positioning blocks are short pieces of molding with one end cut 90 degrees and the other at 45. For simplicity you can simply make all 6 or 8 the same length. The wide side should stand up in the miter box for the 45 cut.

If the Keyboard Shelf is close to the filling cabinet then only 6 blocks are needed. If you are making a long desk then cut 8 and move the monitor cut-out over.

Pre-drill the block for #4 finishing nails. This is easily done by cutting the head off a nail and using it for a drill bit.

9. Legs

The leg pieces can be cut to length with the miter box and hand saw. One piece needs to be notched. The length of the four leg pieces many need to be adjusted to exactly suit your filling cabinet. It is easiest to make the legs long and trim them. Be sure to consider the feet in making your measurement. The leg assembly is held together with nails and glue.

If you are using a solid core door, then you can make the leg assembly a little narrower and have the legs set in a little. Make the legs the same width as the filling cabinet looks best.

10. Keyboard Shelf

If you are cutting the door off to fit your floor space, you may need to size the keyboard shelf to fit. If you have a solid core door, then the Keyboard Shelf supports do not need to reach all the way across the desk.

You can also set the keyboard height to whatever you need by trimming the support boards, adding molding to make them wider, or simply using 1-by-6 lumber.

The Monitor Well cut-out must be the same width as the cut-out in the door.

Assemble the Keyboard Shelf with screws and glue. Pre-drill the four small screw blocks for two screws each.

11. Building the Monitor Well

The Monitor Well has a 1/2 inch plywood shelf and two sides. Molding hides the edge of the plywood where it shows.

Cut a piece of molding to fit the back of the monitor cut-out. Pre-drill it and nail and glue it in place.

Cut out the two side pieces. Drill three lines of holes on one inch centers as shown in Sketch #12. The distance from the front to back line is 10 inches. Cut out the material between the back two lines of holes to make slots. Make sure the Monitor Shelf bolts slide easily in these slots.

Try fit the sides into the door cut-out and cut molding to cover the top and front edges of the plywood. Pre-drill these pieces and nail and glue them to the Well Sides. Shape the lower front corner of the sides to whatever looks good to you.

Install the Well Sides with screws along the top. If you do not use glue then you will be able to take the desk apart later. This is important if you want to reduce the size of the sides to improve your leg room.

12. **Monitor Shelf**

The shelf is shown in Sketch #12. It is simply a piece of 1/2 inch plywood and six pieces of molding. The piece of molding across the back keeps things from sliding off the tipped shelf. The molding across the front simply hides the plywood edge.

The two pieces of side molding are drilled for two "T" nuts each 10 inches apart.

The small block in the center is to position the monitor. You should cut this to suit your specific monitor base. You will attach it with screws only later.

Install the Monitor Shelf with four 1--1/4 inch long 1/4 inch bolts. Use both a flat washer and a large fender washer on each one. The fender washers keep the bolt from cutting into the wood. You will later adjust this shelf to suit your monitor.

13. **Placing the Cabinets**

Place the door back on the floor best side down. Place the empty filing cabinet in place upside down on the door. Position it equal distance front to back and one inch from the filled end.

Place eight positioning blocks around the corners of the filing cabinets. Place a thin piece

of cardboard, like a piece of manila folder, between the block and the cabinet. Attach the blocks with nails and glue.

14. **Placing the Shelf**

Place the shelf in position. Install two screw blocks between the shelf and the Well sides. Glue these to the shelf only. These blocks will cover some of the front holes in the Well Sides.

15. **Attach Legs**

Position the leg assembly. Install it with screws but no glue. If the angle bracket interfere with parts of the Keyboard Shelf then take the shelf off and cut a notch.

16. **Cable Protection Blocks**

The two Cable Protection Blocks are cut from the same molding as the Positioning Blocks but have two beveled ends. Pre-drill and nail them to the back edge of the door. These prevent the door from crushing the computer cables against the wall.

If you like, you can add some eye hooks along the back edge of the door. These allow you to tie the computer cables up out of the way.

17. **Finish the Desk**

Hand sand all sharp edges. Spend some time on the front edges of the exposed keyboard shelf parts so that the edges feel comfortable to rub against. Round the four door corners a little too.

It is easiest to remove the legs and keyboard shelf for finishing.

The door is usually simply hand sanded, stained, and covered with two coats of polyurethane varnish. Several applications of stain may be needed to get the edges of the door to be as dark as the top.

All the parts below the desk top are usually stain or painted a dark color often to match the filing cabinet

18. **Adjusting the Monitor Shelf**

This is a trial-and-error operation. Take the time to try several positions. If your health

care provider has made any suggestions -- follow them --.

Set the desk up and place the keyboard and mouse in place. Guess at the best position for the Monitor Shelf and install all four bolts finger tight. Set the monitor in place.

Sit up straight in your good chair -- you need a good chair --. Do not slouch Your view of the bottom of the monitor should be clear of the back edge of the keyboard. The center of the screen should be perpendicular to your line of sight.

Your neck should feel comfortable and be in a neutral position. Neutral means that the muscles that pull the head forward and those that pull it back should be equally balanced. Take the time to try several positions.

When its right, tighten the shelf bolts. You may want to repeat this adjustment after you have used the desk for a few weeks.

Conclusion

Congratulations, you have complete a good, low-stress computer desk. This desk is an important part of your plan to reduce computer use stress.