

Beds – Viking Age Design

These bed designs are based on a Viking Age design.

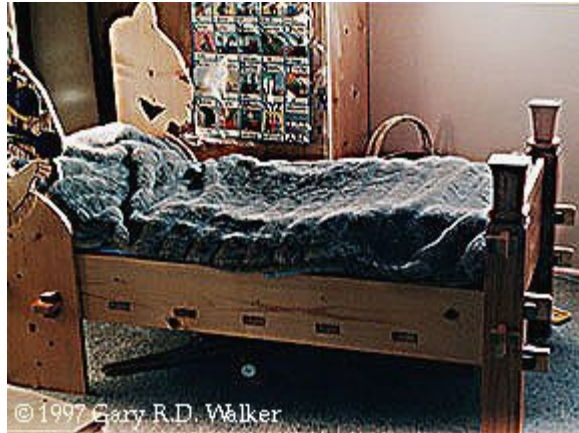

This is the second of my adaptations of the bed design. Note that the headposts are not angled, instead a two layer mortise is used. Also all the slats extend through the side rails and are pegged. This is an adaptation to the use of pine and prevents bowing of the slats. The mortices in the footposts have also been slightly altered. The bed has been sized to take a modern full size mattress. No attempt was made to follow the original measurements, but things were kept in relative proportion. Square pegs were used in this version.



This is the third of my adaptations of the bed design. This bed is fitted to take a crib mattress, and the proportions reduced accordingly. The headposts have a design of squirrel heads in Norse style. Due to the the reduced size most of the slats have been cut flush with the side rails like the originals.

My most recent adaptation of the bed design is another full size bed in oak. The slats on this one are mostly flush with the side rails like the above example. This model has angled round mortises for the angle cut round pegs.

The Bed consists of:

- 1 Headboard (figure 7)
- 2 Headposts (carved) (figure 9)
- 1 Footboard (figure 6)
- 2 Footposts (figures 10 & 11)
- 2 Side rails (figure 8)
- 6 Short slats (figures 1 & 2)
- 2 Medium slats (figures 1 & 4)

1 Long slat (figures 1 & 5)
 Pegs (figure 3)

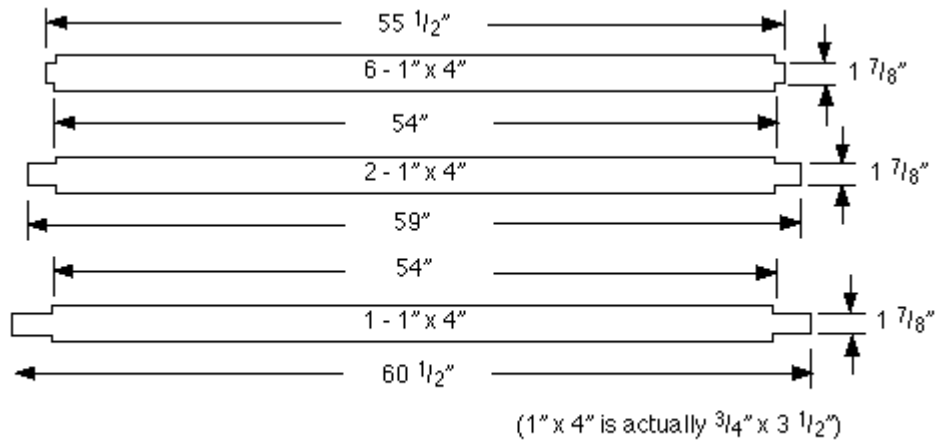

Figure 1: Bed slats

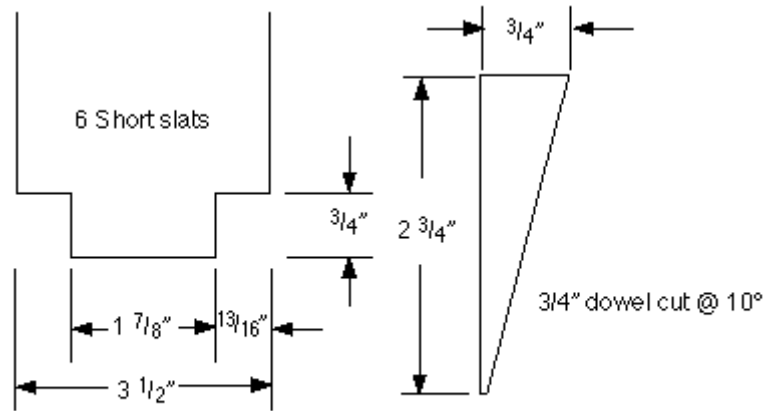

Figure 2

Figure 3

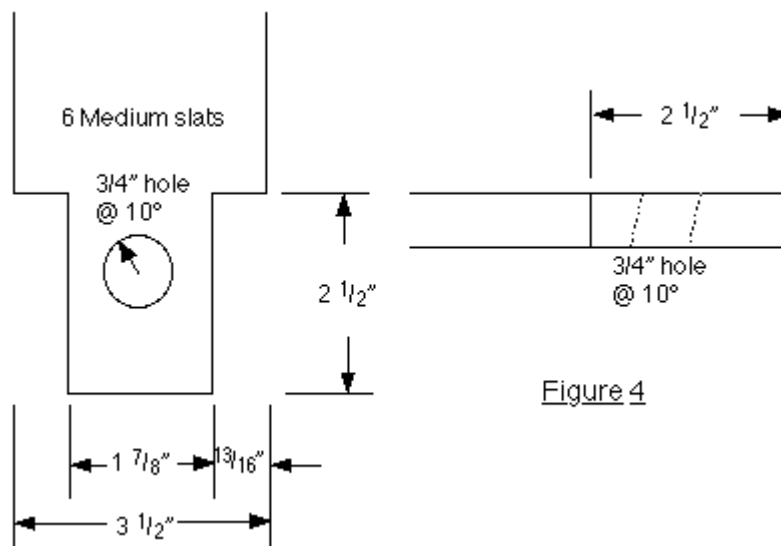

Figure 4

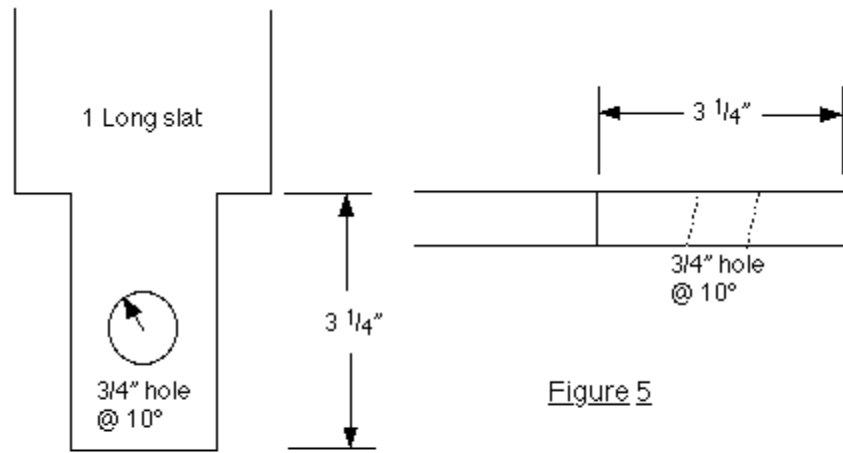

Figure 5

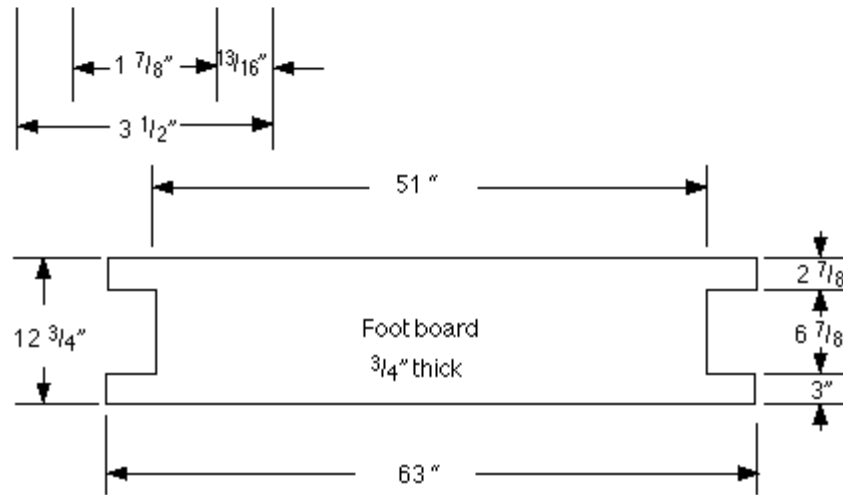

Figure 6

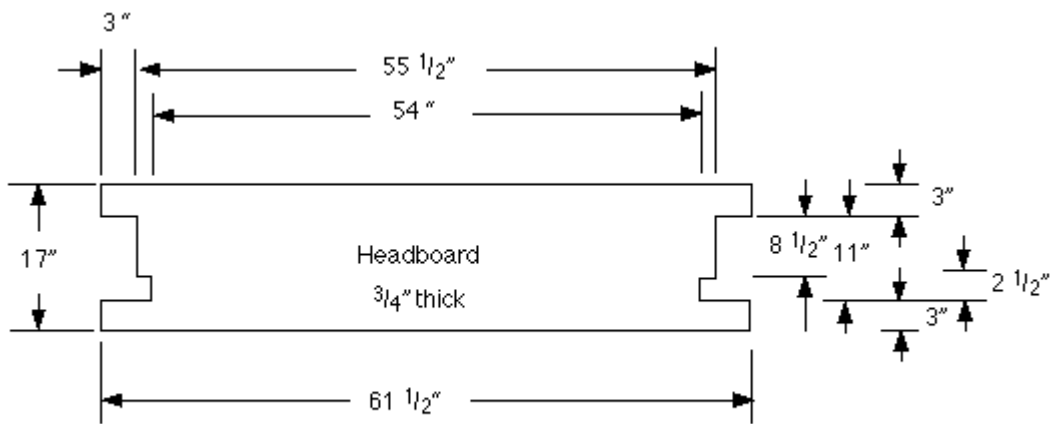

Figure 7

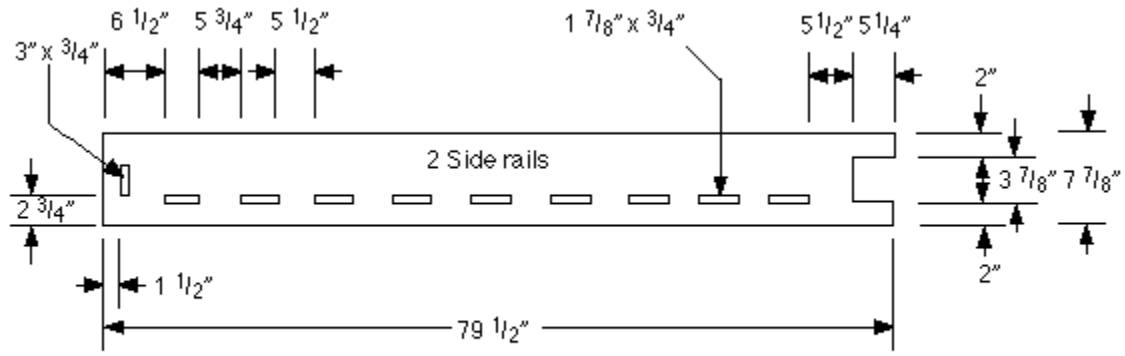

Figure 8

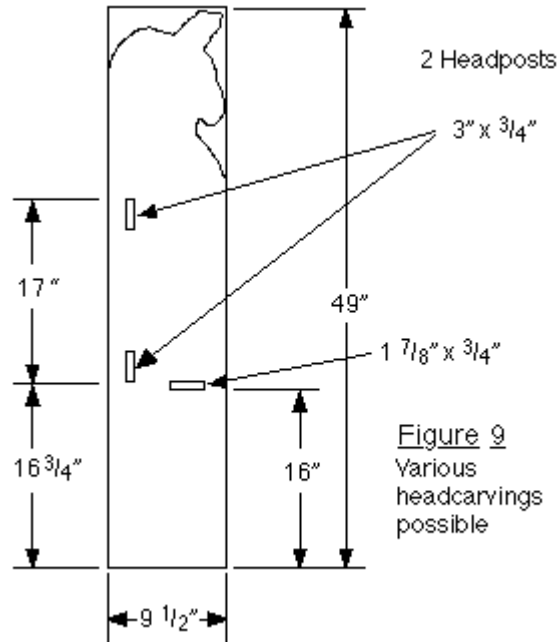
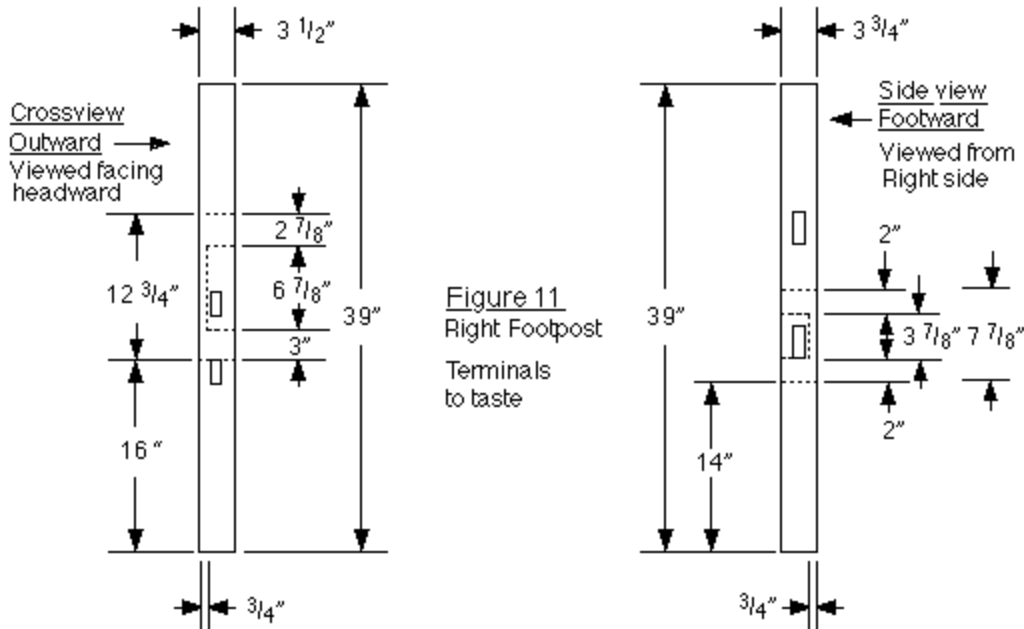
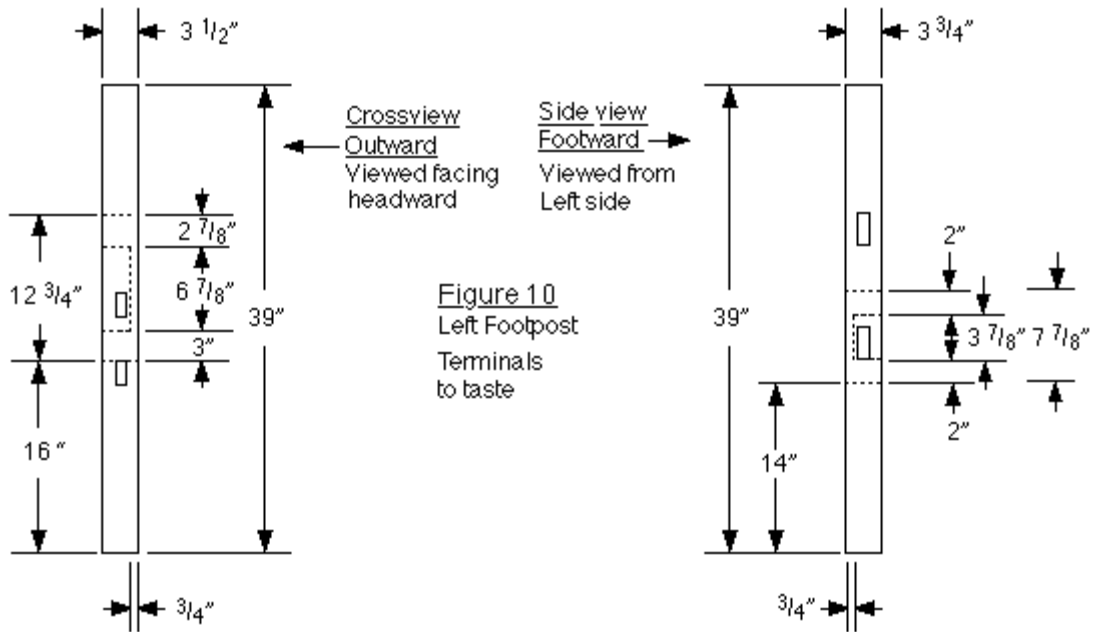

Figure 9
Various headcarvings possible



To assemble:

This is easiest to do with two people.

Take one side rail, fit headboard and long slat at square end of side rail (side rail slots should have the short side to the ground) with headboard vertical; fit other slats in the remaining slots; peg all medium slats in position.

Take second side rail and starting at the headboard, fit the headboard and slats in the slots; peg the medium slats in position loosely.

Take the footboard and the footposts and place the footboard in the long slots in the posts (work back and forth carefully if they stick); do not yet peg.

Take the foot assembly with the next largest set of slots towards the slat assembly; pick

up slat assembly and tilt foot assembly to match angles; work foot assembly carefully onto side rails, this will require rocking the foot assembly and keeping progress equal on both sides, also side rails may be slightly twisted in relation to slots, just adjust the side rail angle to correct; peg medium slats and foot assembly.

At headboard take headposts with carving on outside and heads facing foot of bed; raise bed assembly to level with headpost slots; work on carefully and peg.

Lightly tap in pegs with suitable hammer.