



Wow! I Made It.com

## Desk Organizer

*It's always the small things in life that drive me right over the edge—like hunting for a pencil and paper to write down an address or telephone number. After fumbling through every desk drawer, I used to record important information with a magenta crayon stub on the back of my water bill, but all that has changed since I made this desk organizer. It has three drawers for note pads, pens, and pencils, and a shelf large enough to hold my phone.*



## **Special Tools and Techniques**

- Router and roundover bit (optional)
- Mitering

## **Materials and Supplies**

- 8 linear feet of 1 x 4 pine
- 4 linear feet of 1 x 8 pine
- 6 linear feet of 1 x 10 pine
- 1 piece of 1/4"-thick plywood, 14" x 16"

## **Hardware**

- Approximately 50 #6 x 1/4" flathead wood screws
- Approximately 50 3d finishing nails
- 1 small box of wire brads
- 3 decorative drawer pulls

## **Cutting List**

Code	Description	Qty.	Material	Dimensions
A	Top/Bottom	2	1 x 10 pine	26-1/4" long
B	Inner Divider	2	1 x 10 pine	3-5/8" long
C	Side	2	1 x 8 pine	9-1/4" long
D	Back	1	1 x 8 pine	27-3/4" long
E	Drawer Front/Back	6	1 x 4 pine	8" long
F	Drawer Side	6	1 x 4 pine	7-1/2" long
G	Drawer Bottom	3	1/4" plywood	6-3/4" x 7-3/4"

## **Notes on Materials**

Before you shop for the necessary materials for this project, check your workshop for scrap pieces and compare what you might find with the pieces in the "Cutting List." Most of the wood you need may be lying around on your workshop floor!

## **Making the Frame**

1. Cut two 26-1/4"-long top/bottom pieces (A) from 1 x 10 pine.

2. Cut two 3-5/8"-long inner dividers (B) from 1 x 10 pine.
3. Place the top/bottom pieces (A) on a level surface, parallel to each other, on edge, and 3-5/8" apart. Fit the two inner dividers (B) between the two top/bottom pieces (A), spacing them 8-1/4" from each other and from the ends, as shown in *Figure 1*. Glue the inner dividers (B) in place and drive three evenly spaced 1-1/4" screws through the top/bottom pieces (A) and into the edges of the inner dividers (B) at each joint.

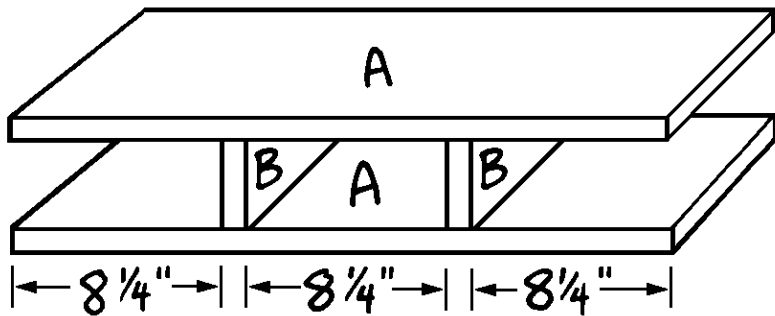

*Figure 1*

4. From 1 x 8 pine, cut two 9-1/4"-long sides (C).
5. Position the sides (C) on the assembly as shown in *Figure 2*. Note that the sides (C) are flush at the front, back, and bottom of the assembly, but extend above the top face. Glue the sides (C) onto the ends of both of the top/bottom pieces (A) and secure them in place with three 1-1/4" screws at each joint.
6. Cut one 27-3/4"-long back (D) from 1 x 8 pine.
7. Attach the back (D) to the assembly, as shown in *Figure 2*. Note that the back (D) is flush with the assembly at the bottom and at the sides, but extends above the top/bottom piece (A). Glue the back (D) to the edges of the top/bottom pieces (A) and to the ends of both sides (C). Drive three 1-1/4" screws through the back (D) at each joint.

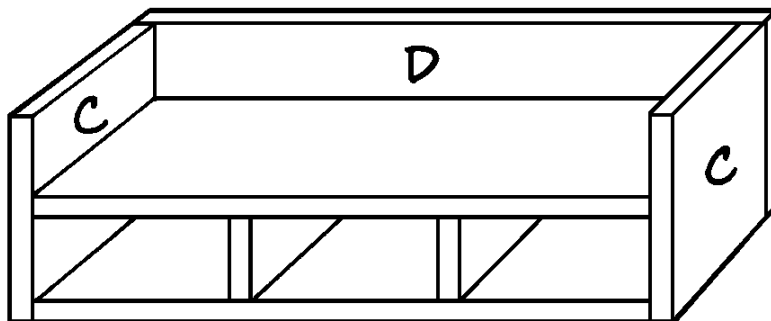

*Figure 2*

8. If you own a router and roundover bit, use them to round the upper edges of the sides (C) and back (D). If you don't own a router, simply sand the edges with very rough sandpaper and then finish with increasingly fine grades of sandpaper.

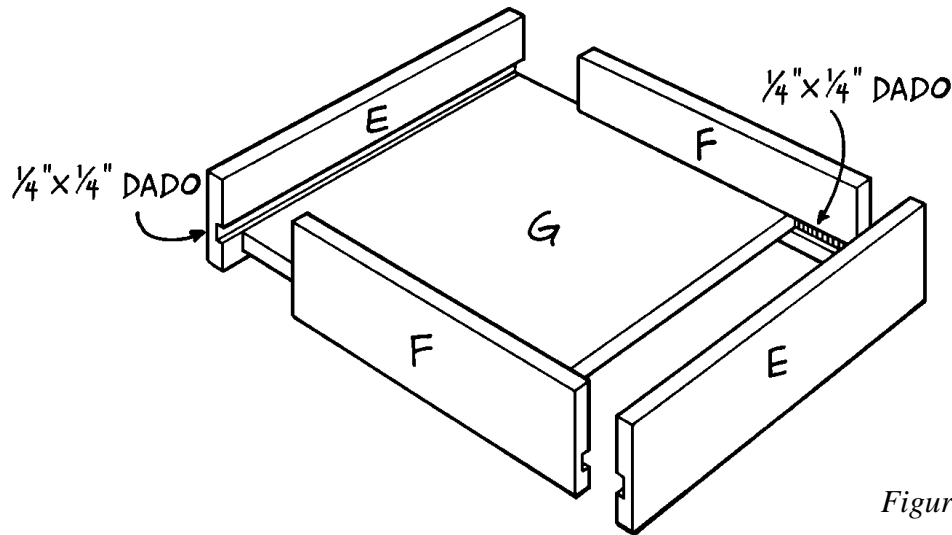

Figure 3

### Making the Drawers

1. The three identical drawers for this organizer are constructed as shown in *Figure 3*. From 1 x 4 pine, cut six 8"-long drawer front/back pieces (E) and six 7-1/2"-long drawer sides (F).
2. To accommodate the plywood drawer bottoms (G), cut a 1/4' x 1/4' dado on the inside of every drawer piece (E and F), 3/4 from its lower edge.
3. Cut three 6-3/4" x 7-3/4" drawer bottoms (G) from 1/4"-thick plywood.
4. Assembly one drawer as shown in *Figure 3*. Note that the drawer front/back pieces (E) overlap the ends of the drawer sides (F). Use glue and 3d finishing nails at each end of the overlapping boards.
5. Repeat Step 4 two more times to assemble the remaining two drawers.

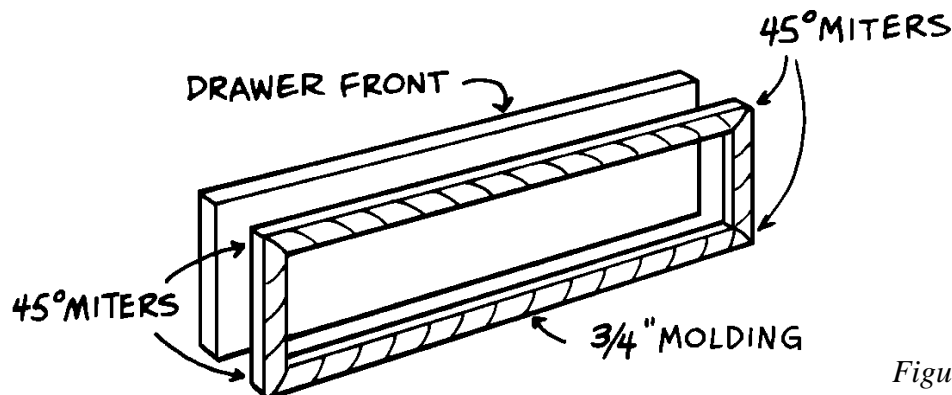

Figure 4

## ***Adding the Drawer Trim***

1. Each of the drawer fronts (E) is trimmed with  $\frac{3}{4}$ -wide decorative molding. To trim the first drawer front, cut and fit pieces of molding, mitering the ends so that they fit perfectly flush with the outer edges of the drawer front (E), as shown in *Figure 4*.
2. Glue the molding in place and use a tack hammer to drive tiny wire brads through the molding and into the drawer front (E). Recess the nails with a nail set.
3. Repeat Steps 1 and 2 twice more to trim the fronts of the remaining drawers with molding.

## ***Finishing***

1. Fill any holes or crevices with wood filler.
2. Sand all surfaces of the complete drawers and frame thoroughly.
3. Paint or stain the completed desk organizer the colors of your choice. I chose pale green and mauve to match the colors in the room where my organizer makes its home.
4. Follow the manufacturer's instructions to install a drawer pull in the center of each drawer front.
5. Insert the drawers into the frame and begin organizing!

---

**Build many other exciting indoor and outdoor projects from**

**!**

