

129

KITCHEN BASE CABINET



There are two sorts of kitchen cabinets: base cabinets, which sit on the floor, and wall cabinets. Base cabinets provide both storage space and work surfaces. They often house sinks, such large appliances as dishwashers, and sometimes smaller

conveniences, such as slide-out shelves or cutting boards.

Construction: The basic cabinet is made of a plywood case (sides, floor, and back) and a counter top covered with plastic laminate. Hardwood trim defines

Parts list						
Part	Name	Quantity	Thickness	Width	Length	Material
A	Right (wall) side	1	3/4"	22 1/2"	31"	Birch plywood
B	Left (outer) side	1	3/4"	23 1/4"	35 1/4"	Cherry plywood
C	Divider	1	3/4"	22 1/4"	31"	Birch plywood
D	Cabinet floor	1	3/4"	22 1/2"	46 1/2"	Birch plywood
E	Shelf	1	3/4"	8"	22 1/2"	Birch plywood
F	Drawer side	6	1/2"	4 1/2"	22"	Birch plywood
G	Drawer side	4	1/2"	8"	22"	Birch plywood
H	Drawer front and back	4	1/2"	8"	21"*	Birch plywood
I	Drawer front and back	6	1/2"	4 1/2"	21"*	Birch plywood
J	Drawer bottom	2	1/4"	20 7/8"*	21"*	Birch plywood
K	Drawer bottom	3	1/4"	20 7/8"*	21"*	Birch plywood
L	Back	1	1/4"	31 3/4"	46 1/4"	Birch plywood
M	Door panel	1	1/4"	19 3/8"	21 1/8"	Cherry plywood
N	Drawer face	2	1 3/16"	9 3/8"	23"	4/4 cherry
O	Drawer face	3	1 3/16"	5 1/8"	23"	4/4 cherry
P	Kickplate	1	1 3/16"	3 1/2"	48"*	4/4 cherry
Q	Trim	9	1 3/16"	1 1/4"	†	4/4 cherry
R	Door stile	2	1 3/16"	2"	25 1/8"	4/4 cherry
S	Door rail	2	1 3/16"	2"	20 1/2"	4/4 cherry
T	Door panel clip	4	3/8"	1 3/16"	1/8"	4/4 cherry
U	Plug	24	3/8" dia	—	1/4"	4/4 cherry
V	Bracing strip	2	3/4"	1 1/2"	45 1/2"	1 x 2 pine
W	Bracing strip	2	3/4"	1 1/2"	19 1/2"	1 x 2 pine
X	Batting strip	1	1/2"	1/2"	72"*	1 x 2 pine
Y	Batting strip	1	1/2"	1/2"	24 1/2"*	1 x 2 pine
Z	Platform beam	2	1 1/2"	3 1/2"	46 1/4"	2 x 4 fir
AA	Platform beam	2	1 1/2"	3 1/2"	16"	2 x 4 fir
BB	Counter top	1	3/4"	25"*	73"*	Particle board
CC	Backsplash (optional)	1	3/4"	18"*	73"*	Particle board

*Measurement is approximate; cut to fit during construction.
†One piece 30 1/4" long for divider, one 22 1/8" long for shelf; and two 22 3/8" long, two 32 1/4" long, and three 45 1/2" long for cabinet face. Check measurements before cutting.

Tools and materials: Radial arm or table saw with dado head. Saber saw, backsaw. Router with straight veneer trimmer, bevel veneer cutter, arbor, and pilot, 3/8" rabbeting bit, and 45° chamfer bit. Electric drill with set of twist bits, No. 10 plug cutter, and Nos. 8 and 10 combination pilot, clearance, and Counterbore bits. Wide chisel, 3/16" chisel, fine laminate file Hammer screwdriver. Several 5' pipe or bar clamps, several 6" C-clamps, vise. Framing square, combination square, level, steel tape rule, compass, utility knife, pencil. Rubber-surfaced pressure roller or rolling pin. Belt sander with No. 120 sanding belt Nos 80, 100, 150, and 220 sandpaper. Masking tape, carpenter's glue, construction adhesive, contact cement Lacquer thinner

or equivalent solvent, tung oil, soft cloths One 4' x 8' panel each of 1/4", 1/2", and 3/4" birch-veneer lumber-core plywood and of 3/4" high-density particle board. One 2' x 4' panel each of 1/4" and 3/4" cherry-veneer lumber-core plywood, 48' of 4/4 cherry, 20' of 1 x 2 clear pine, and 11' of 2 x 4 fir Cedar shingles. Enough 1/16" plastic laminate to cover surface and edges of counter top Two flush-mounted pivot hinges, five pairs of 20" metal drawer slides, one magnetic door catch, six small round drawer/door pulls. 2d, 3d, 4d, 8d, and 12d common nails, 4d and 6d finishing nails, 7/8" No 6 roundhead wood screws and the following flathead wood screws: 5/8" No 4, 1/2" No 6 1", 1 1/2", and 2" No 8, and 1 1/4" No 10

Kitchen base cabinet

the openings for the door and drawers and reinforces the case. The case is fastened to a platform that has been leveled with tapered shingles used as shims.

Do-it-yourselfers who build kitchen cabinets often order custom-made counter tops. It is a good idea to do so if you need a large or L-shaped top. Otherwise, you can make your own as shown and save a good deal of money.

Variations: The base cabinet described in this project has five drawers and a wood-paneled door that opens to reveal a shallow fixed shelf. You can easily rearrange, increase, or eliminate the elements to suit your needs. You can also redesign the cabinet to house a sink.

The directions that follow are for a cabinet 3 feet high and 2 feet deep that will fit beneath the kitchen wall cabinet in the next project. The counter top is designed to cover not only the cabinet but a dishwasher or other appliance as well. You can build the base cabinet exactly as it is shown here if you wish, but you will have to adapt at least the length of the counter top to fit your own kitchen.

A base cabinet has two types of sides. One side (the right, as described in the directions that follow) reaches only to the cabinet floor, which rests on top of a platform. It should be placed against a wall or butt against another cabinet on a common platform. The other side (the left) reaches all the way to the kitchen floor, masking the platform. It should be placed against a large appliance or be left exposed. If it is exposed, use cherry-veneer plywood and fill the screw holes with cherry plugs as used on the face of the cabinet. If the left side of the cabinet will not be seen, use less-expensive birch plywood and leave out the plugs. If both sides of your cabinet will be visible, use the measurements, techniques, and materials given for the left (outer) side for both sides of your cabinet. If both sides butt against walls or other cabinets, use only the measurements, techniques, and materials shown for the right (wall) side.

You may want to install a backsplash, which will prevent liquids from running off the counter top and down the wall. Although a short backsplash is equal to the task, the 18-inch-high backsplash recommended is easier to keep clean and provides a level support for a wall cabinet. If you plan to install a wall cabinet above your base cabinet, a high backsplash will make the job easier.

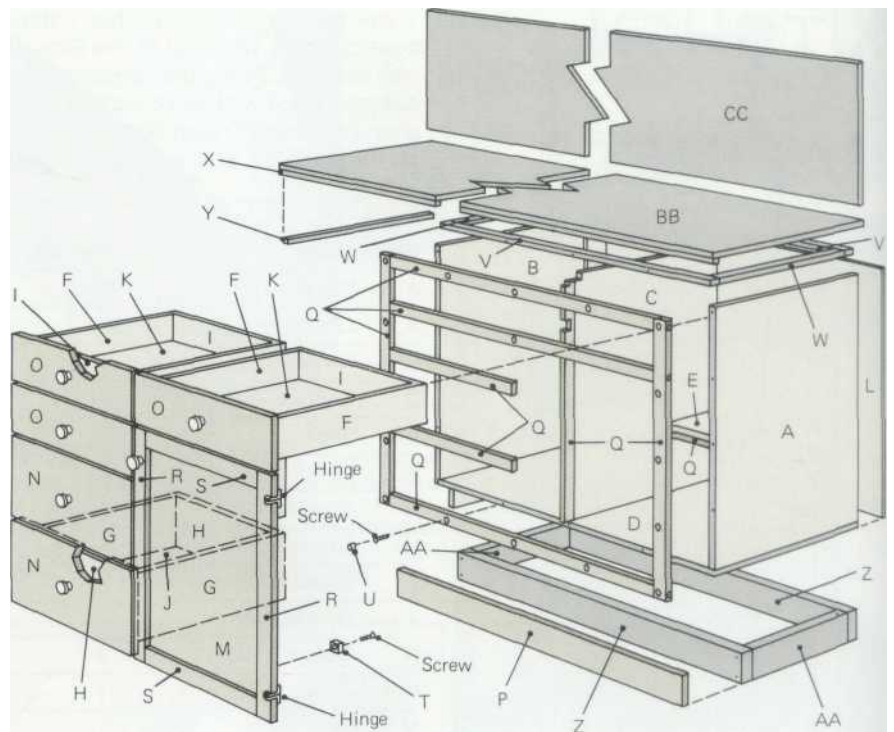

Patterns for dados, rabbets, and notches

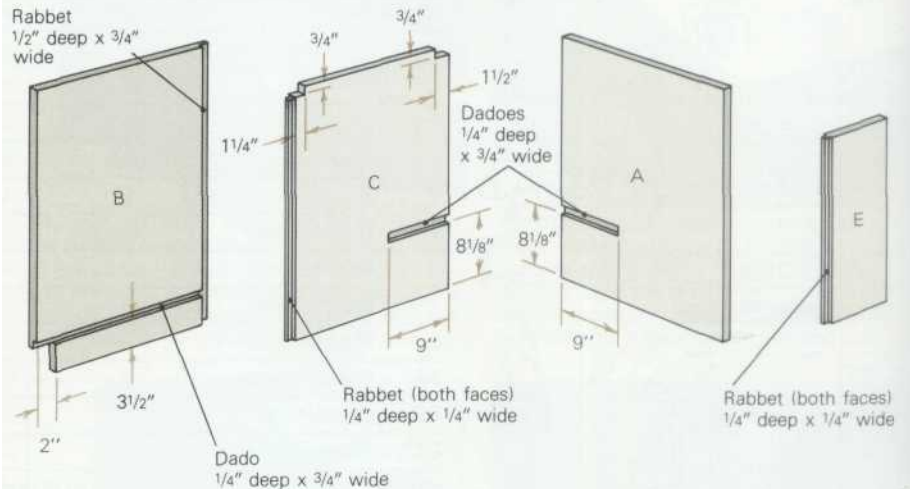

Variations

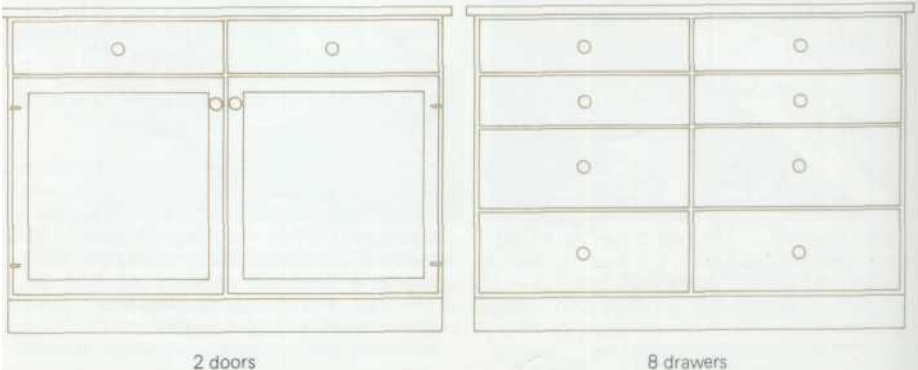

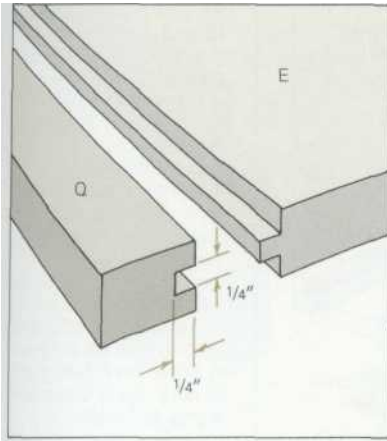

1. Cut parts A-E to sizes in chart
Then cut dados, rabbets, and notches shown in patterns Cut trim (Q) for divider (C) and shelf (E) and cut a 1/4- x 1/4-in. dado down center of back edge of each trim piece. Apply glue to dados, push trim onto tongues created by rabbets in divider and shelf. Clamp until dry. Belt-sand trim flush with divider and shelf.

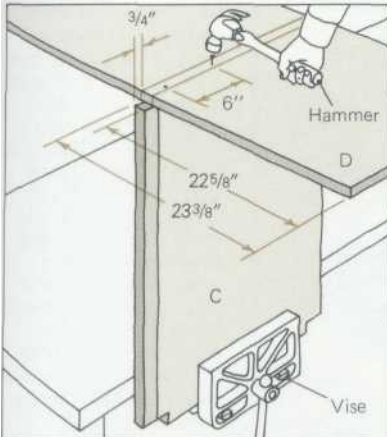

2. Draw lines across top of cabinet floor (D) 22 5/8 and 23 3/8 in. from left edge. Continue lines on bottom of floor Clamp divider (C) upside down in vise and glue floor to its bottom edge so that divider meets floor between lines and divider trim extends 3/4 in beyond front of floor. Using lines on bottom of floor as guide, drive 4d common nails through floor into bottom of divider every 6 in. Keep connection squared while doing so.

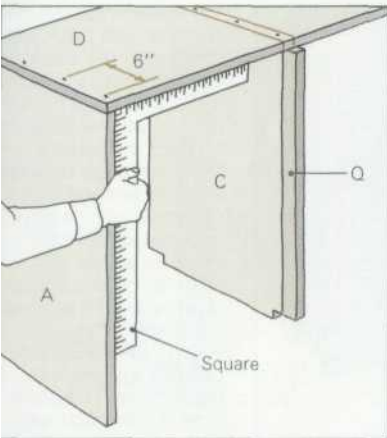

3. Apply glue to bottom edge of right cabinet side (A) and set cabinet floor (D) upside down on top of it so that all outer edges of the two pieces are flush. Drive 4d common nails through cabinet floor into bottom edge of side every 6 in., stopping to check for squareness after driving in each nail. It is of utmost importance that the cabinet be square, as the smooth operation of the drawers and door will depend upon it.

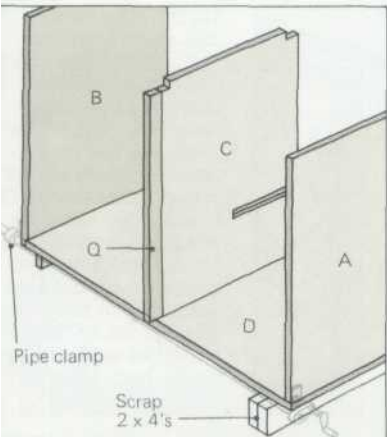

4. Turn assembly right side up Apply glue to long horizontal dado in left cabinet side (B) and insert left edge of cabinet floor into it so that front edges of floor and side are flush. Clamp unit and prop up opposite side of cabinet floor with two scrap 2 x 4's set on edge so that cabinet will sit level until the glue dries.

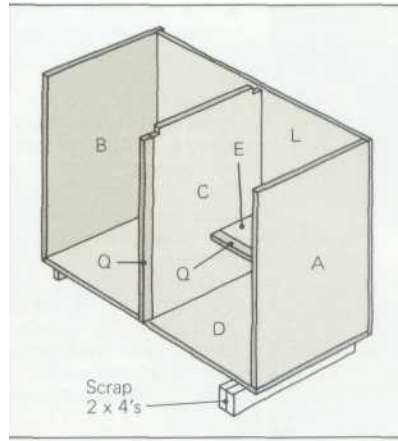

5. Slide shelf (E), with its trim facing the front, into dados in divider (C) and right side (A) Cut back (L) to size and glue it in place so that it sits in rabbet in left side and is flush with bottom of cabinet floor (D) and outer edge of right side Tongue of left side will extend a bit beyond back Secure back with 4d common nails.

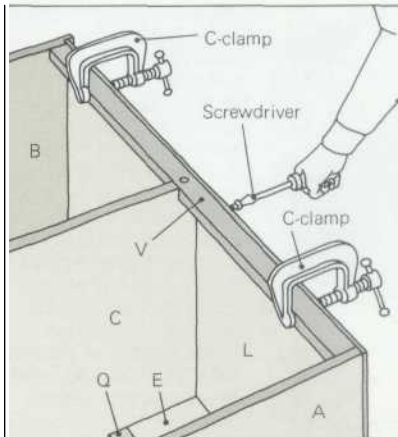

6. Check measurement and cut long bracing strips (V) to size. Clamp one strip along inside of back (L), fitting it into notch at top of divider (C) so that its ends touch inside of cabinet sides (A and B) Use No. 8 combination bit to drill five evenly spaced pilot holes through back into bracing strip Also drill down through bracing strip into top of divider. Drive in 1 1/2-in. No 8 screws and remove clamps

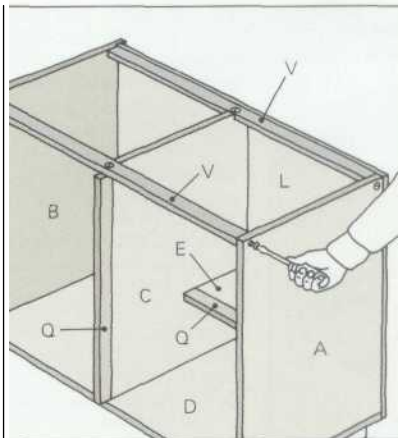

7. Fit other long bracing strip (V) into notch at front of divider so that its ends are flush with tops and fronts of cabinet sides. (Trim on divider will protrude 3/4 in. at front) Use No 8 bit to drill through front bracing strip into divider and drive in a 1 1/2-in No 8 screw. Drill one hole through each side into each end of each long bracing strip and drive 2-in No 8 screws into the holes

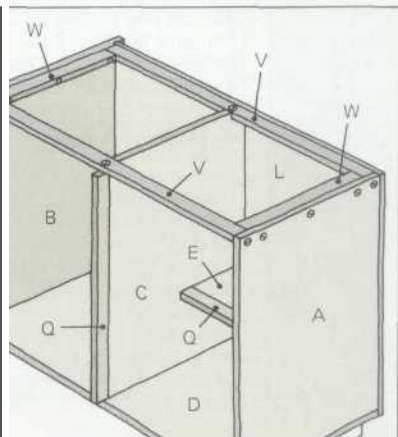

8. Check measurement and cut short bracing strips (W). Clamp one strip against inside of right cabinet side (A) with its ends butting long bracing strips (V). Use No. 8 combination bit to drill three holes through cabinet side into short bracing strip. Clamp other strip to left side. This time, drill pilot holes through strip into side Attach strips with 2-in No 8 screws. Sand inside of cabinet with Nos. 80, 100, 150, and 220 paper

Kitchen base cabinet

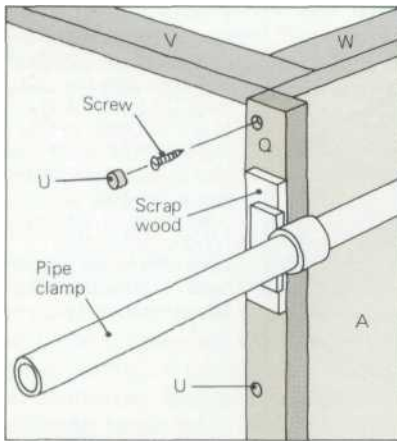

9. Cut trim (Q) for front edges of cabinet sides, and clamp trim flush with inner edges and tops of sides. Use No. 10 bit to drill pilot holes every 8 in. through trim into front edges of sides. Counterbore holes $\frac{3}{8}$ in. deep. Glue and screw trim in place. Remove clamps when glue is dry. Use No. 10 plug cutter to cut plugs (U) from cherry. Glue plugs into screw holes, and chisel and sand their tops flush with trim.

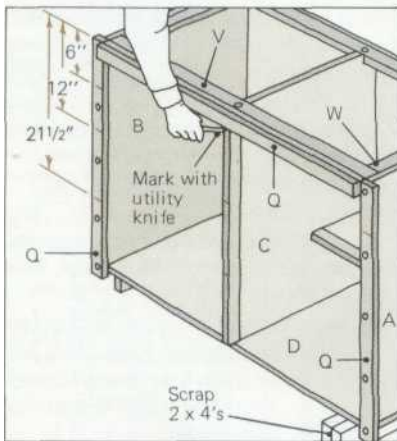

10. Mark trim on cabinet sides 6 in. from top. Mark trim on divider and left side 12 in. and 21 1/2 in. from top. Cut a piece of trim and position it across cabinet front flush with tops of trim on sides. Use a knife to mark divider where trim crosses it. Cut and position a second piece of trim with top edge at 6-in mark and a third piece with top edge flush with top of cabinet floor. Mark divider where these pieces cross it.

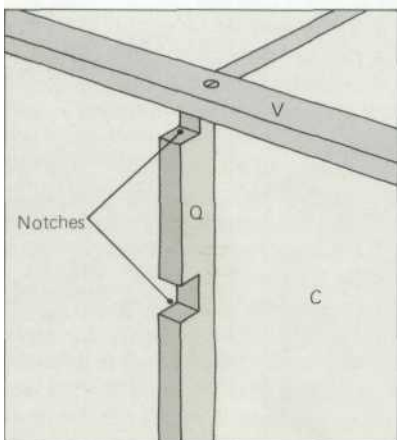

11. Use saber saw to cut $\frac{13}{16}$ -in.-deep notches in divider trim where horizontal trim will hit it, using knife marks as guides. With No. 10 bit drill a deep hole through each piece of trim into divider. Glue and screw trim to divider. Drill pilot holes and glue and screw top trim to bracing and bottom trim to cabinet floor. Plug all holes. Use No. 8 bit to drill through trim on sides into ends of horizontal trim. Drive in 2-in. screws

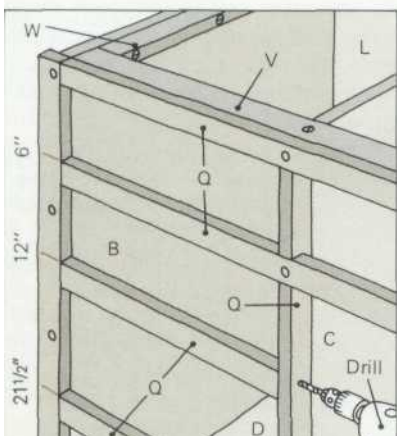

12. Cut two pieces of trim and position them between trim on divider and left cabinet side so that top of one piece is at 12-in. mark and top of other piece is at 21 1/2-in. mark made in Step 10. Use No. 10 bit to drill holes through trim on divider and on left cabinet side into ends of short horizontal trim. Drive in No. 10 screws. Use router with chamfer bit to bevel any edges of trim that will face the door or a drawer.

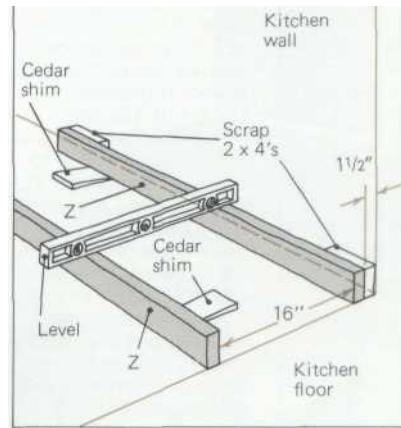

13. Cut platform beams (Z and AA) to size. Position one long beam parallel to wall and 1 1/2 in. from it. Put two short 2 x 4 scraps into gap to maintain spacing and serve as nailing surfaces. Position other long beam parallel to first and 16 in. away. Level each beam, if necessary, by pushing a cedar shingle under it as far as needed. Level beams with each other in same way, being sure to keep each beam level along its length.

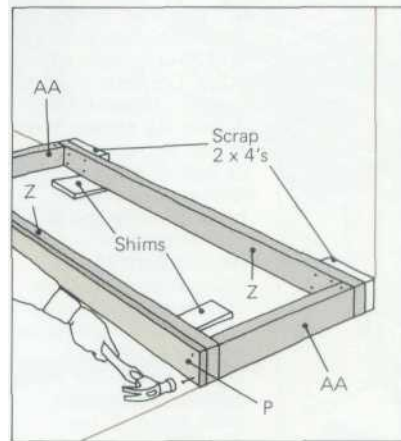

14. Position the short beams (AA) between ends of long ones. Level short beams, then level all beams with each other. Use 12d nails to toenail the 2 x 4 scraps to wall, face-nail inner long beam to scraps, toenail short beams to inner long beam, and face-nail outer long beam to short beams. Also toenail each piece to kitchen floor. Cut kickplate (P), and nail it flush with top of outside beam with 6d finishing nails every 10 in.

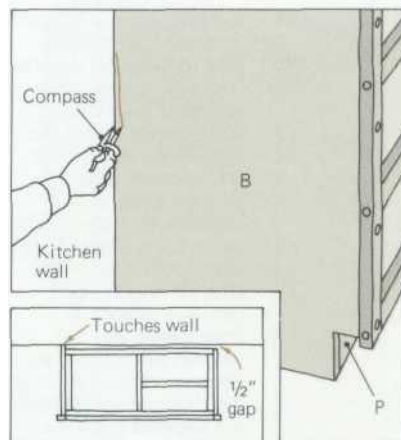

15. Position cabinet on platform with back edge of left side (B) touching wall and cabinet back (L) 1/2 in. from wall. Front of cabinet should be 2 3/4 in. from kickplate. If there are gaps between left side and wall, set a compass with its point and pencil as wide apart as widest gap. Draw point of compass down wall so that pencil will mark contours of wall on left side. Plane or sand away wood behind marks to make side fit flush with wall.

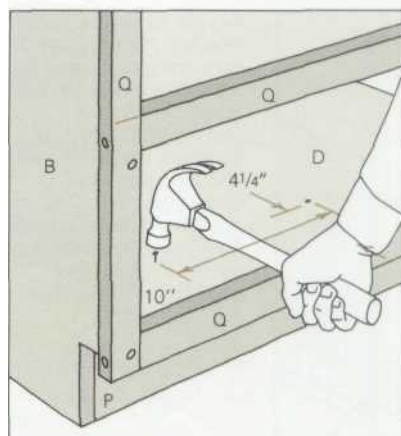

16. Drive 8d nails through cabinet floor into platform every 10 in. Using dimensions in chart on page 115 for parts F-K, make three small and two large drawers. To do so, cut drawer faces (N and O) to size, then follow the directions for making drawers in platform bed, but skip Steps 16-18 and use 20-in. slides instead of the larger ones required for the bed. Sand and set aside drawers. **584**

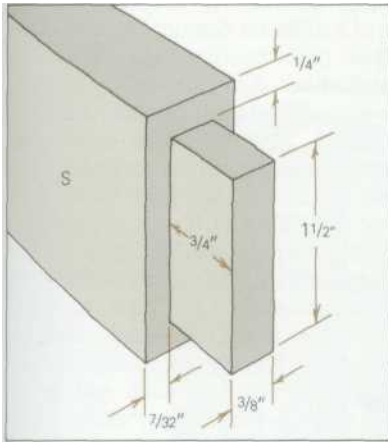

17. Cut door stiles (R) and rails (S) to size. Mark off both ends of both rails for tenons. Each tenon should be 3/4 in. long, 3/8 in. thick, and 1 1/2 in. wide, and have four shoulders. The long shoulders should be 7/32 in. wide and the short shoulders should be 1/4 in. wide as shown. Use table or radial arm saw with dado head to cut the tenons.

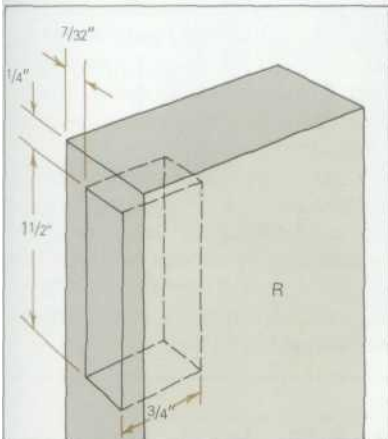

18. Draw cutting lines for mortises on door stiles (R) 1/4 and 1 3/4 in. from each end of each stile and 7/32 in. from each side edge. Test-fit door-rail tenons inside the lines. Cut blind mortises 3/4 in. deep. Glue together, clamp, and square off door frame. When glue is dry, unclamp frame and make rabbets 3/8 in. wide and 1/4 in. deep along inside perimeter of door frame to accept panel. Chisel corners of rabbets square.

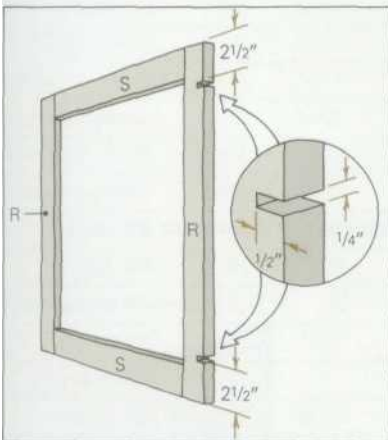

19. Sand door frame with Nos. 80, 100, 150, and 220 paper. Cut two slots on outside face of one door stile, each 2 1/2 in. wide and 1/2 in. deep. Position one slot 2 1/2 in. from top of stile and other slot 2 1/2 in. from bottom. Set hinges into these slots and use pencil to mark positions of hinge screw holes. Drill pilot holes, and screw hinges to stile.

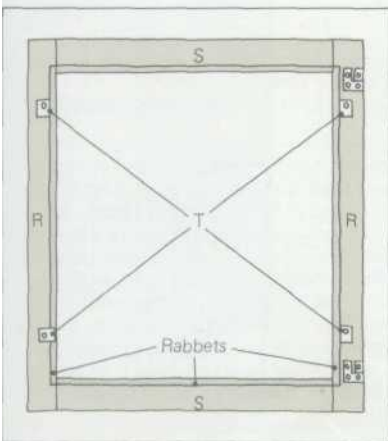

20. Cut door panel clips (T) and drill a 1/8-in. hole 3/16 in. from one end of each. Sand clips and position them on inside of door frame so that when screwed on they can be turned one way to cover rabbets and the other to leave rabbets unobstructed. Mark clip holes on frame, drill 5/64-in. pilot holes, and attach clips to frame with No 6 roundhead screws, but leave rabbets loose enough that clips can be turned.

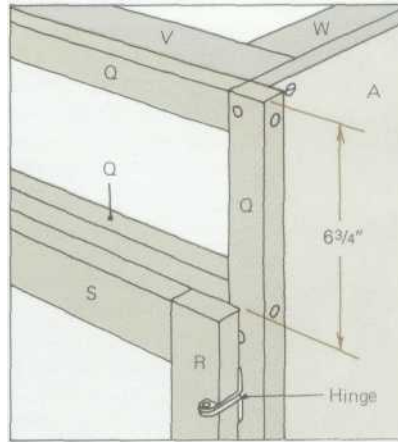

21. Cut door panel (M) to size and test its fit in frame. Trim it to fit if necessary, then sand it. Remove panel and hold frame against cabinet face with rabbets facing in and hinges at right. Top edge of frame should be 6 3/4 in. below top edge of cabinet. Level door frame, then mark cabinet with location of screw holes in hinges. Remove door frame and drill holes for hinge screws. Secure panel in frame, but do not install door yet.

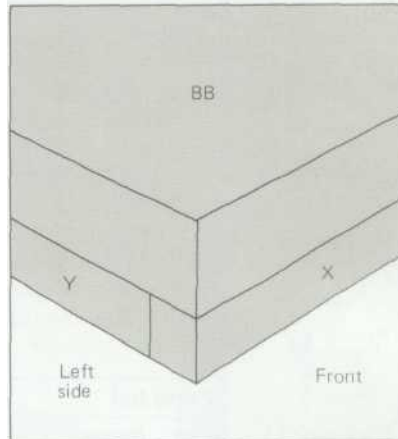

22. Cut counter top (BB) and batting strips (X and Y) to size. Attach batting strips to underside of counter top, flush with its front and side edges, with glue and 3d common nails. Cut plastic laminate for top surface and exposed edges of counter top, allowing for 1/4-in. overhang on all sides. Apply laminate to side edge, front edge, and then top surface of counter top. Trim each piece and bevel edges.

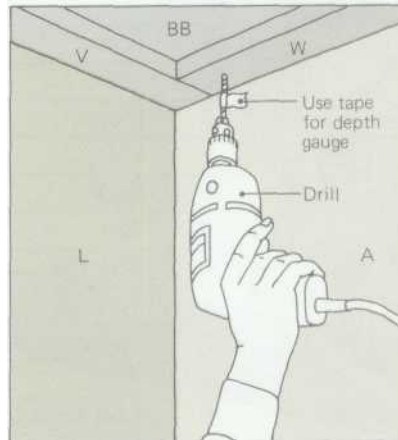

23. Position counter top on cabinet with its long batting strip overhanging cabinet front and its right side flush against wall. Use No 8 bit to drill up through bracing (V and W) into counter top in each corner (Do not drill deeper than 1 1/8 in. or you may pierce top.) Drive in 1 1/4-in. screws. Sand exterior of cabinet, then rub down wood with tung oil. Attach drawer/door pulls; install door, door catch, and drawers.

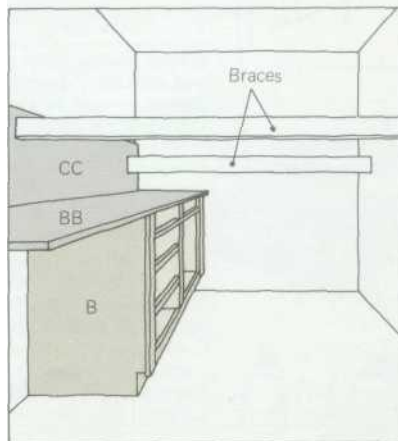

24. If you are installing a backsplash (CC), cut it to size and apply plastic laminate to edges that will show, then to front. Test-fit backsplash on wall. If there are gaps, trim as in Step 15. Glue backsplash to wall with construction adhesive. If possible, brace it with lumber wedged against opposite wall until adhesive dries. Drill pilot holes and drive 2-in. screws through bottom of the counter top into bottom of the backsplash.