

NOTICE

The purchaser agrees when purchasing this product ("Plan") that the purchaser has accepted the right to build or construct the object or project set out in the Plan (the Project) for his/her/his own personal use and not for any commercial use. The purchaser's reproduction of the Plan in whole or in part by any means whatsoever is strictly prohibited. Blueprints for the Handymouse™ are the property of Handymouse™ and no license or permission is granted for the reuse or reproduction of the Plan, in whole or in part, for any purpose other than to construct the Project or for any other purpose. The purchaser agrees to indemnify and hold Handymouse™ harmless from and against all claims, damages, losses or expenses, including reasonable attorneys' fees, resulting from the use of the Plan for any purpose other than to construct the Project or for any other purpose.

NOTE: Read all directions before beginning

- Carpenter's glue should be used to reinforce all joints
- Set all nails and countersink screws - use wood filler as necessary
- Dimensions shown in brackets denote millimeters
- Wipe off excess glue with a wet cloth before it has time to set

Directions:

Procedure 1) - See Figure 1
Begin your project by laying out all materials as illustrated in Figure 1 (Material Layout). Using a pencil, measuring tape and square, lay out all the parts and pieces as shown. All pieces required (along with all the appropriate equipment, tools and dimensions) and shapes illustrated in Figure 2 (Cutting Diagram). Be sure to include the part number designation for each piece as well. The dados in pieces B may be made using a dado blade or using multiple cross cuts, on your table saw. If you don't have a jig saw or band saw, the curved areas can be cut on a hand saw. The curved areas should be cut straight with a table saw, and sanded to final shape.

The angles on pieces D & H are important, as any change in these will affect the fit of other pieces as well as the angle of the seat back. The large 24" radius on that forms the curve of the seat and back. The angle on pieces G & K are important, as a parallel of 24" sitting lead to it. Ensure the focal point of the cutting diagram as precisely as possible using the dimensions as illustrated in the Cutting Diagram.

Due to the complexity and number of various pieces, and as this is an outdoor item, we recommend finishing with stain or oil prior to assembling the project.

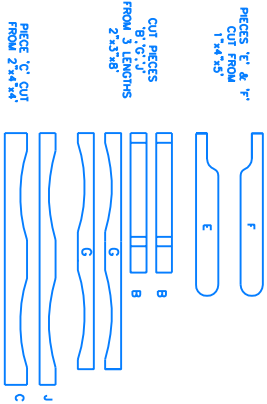

MATERIALS LAYOUT
FIGURE 1

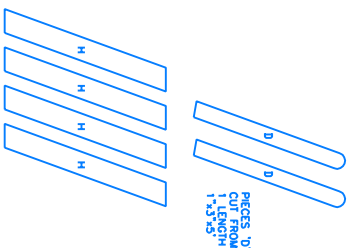

CUTTING DIAGRAM
FIGURE 2

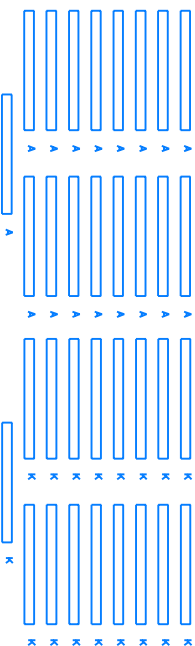
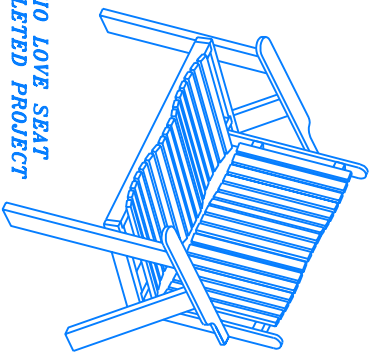
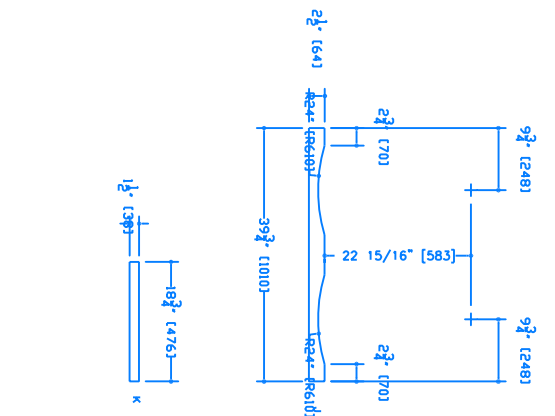
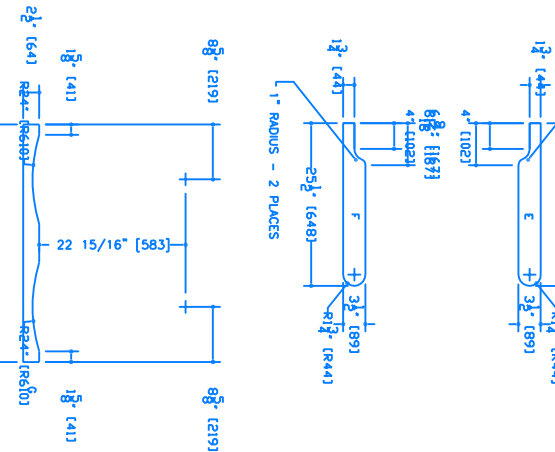
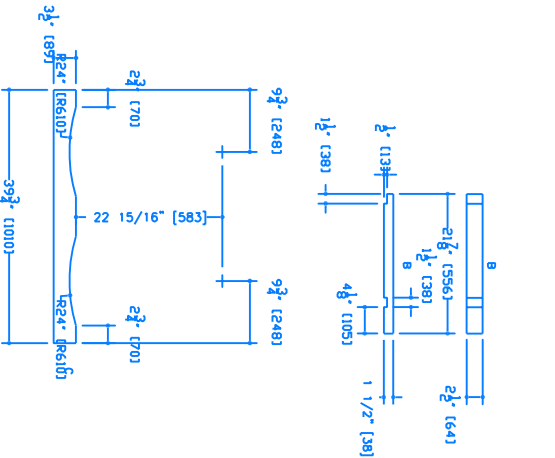

FIGURE 3



PATIO LOVE SEAT COMPLETED PROJECT



MATERIAL LIST

- Three 2"x3"x8" (Cedar or Redwood)
- Three 2"x4"x8" (Cedar or Redwood)
- One 1"x3"x5" (Cedar or Redwood)
- One 1"x4"x5" (Cedar or Redwood)
- Eight 1"x2"x8" (Cedar or Redwood)

MATERIAL LIST

- Approx. 1/2 lb. 1-1/2" Flathead Screws
- Approx. 1/4 lb. 2-1/2" Flathead Screws
- Carpenter's Glue
- Sander
- Oil or Stain

TOOLS

- Table Saw and Jigsaw
- Pencil, Tape, and Square
- Power Drill and Protractor
- 5/64" 3/32" 7/64" drill bits
- Hammer and Screwdrivers
- Paint Brush and Putty Knife
- Power Sander (optional)