

# 149

## TRIANGULAR TABLE

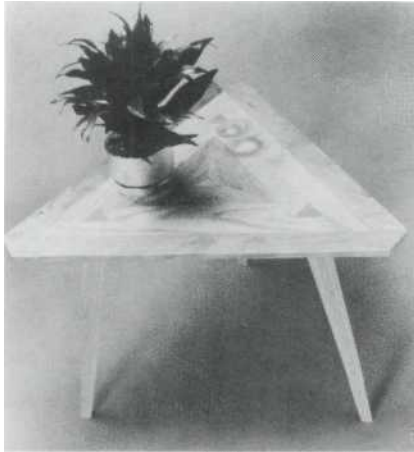

Here's the solution to uneven tables that constantly wobble: a three-legged triangular table. While the idea is a simple one, figuring out the angles provided a challenge. The result is a sturdy table with tapered legs that fit into mortises formed by bevels and compound miters. To build it, use the following step-by-step procedure:

1. Choose wood for this project that is both strong and stable. Ash and cherry were used in this example; the harder ash is ideal for the legs and leg mortises, with the cherry serving as a contrast in the areas of less strain.
2. Because the tapered legs (E) go entirely through the tabletop, the mortises into which they fit must be a particular angle and shape. The easiest way to accomplish this is to construct these angled mortises with beveled and angled parts to make up the tabletop. Begin construction by cutting out on a bandsaw the three isosceles triangles that form the inside of the tabletop (A).
3. Disc sand the triangles so they are identical, then mark the bottom of each one with an X. Cut 1/4"-wide x 1/2"-deep spline grooves on the two inside edges of each triangle, making sure that the X is kept away from the rip fence.

4. Glue and clamp the triangles together. After the glue has dried, use a disc sander to touch up the outside edges of this inner triangle.

5. The top middle pieces (B, C) also form the leg mortises. This means that each part must have one beveled edge, one mitered end, and one compound mitered end. First, cut three pieces of stock that measure 1-1/2" x 1-3/4" x 14".

6. Tilt the saw table 5° and bevel one edge of each board. Mark an X on the wide edge of each board to indicate the bottom side. Now return the table to 0°, set the miter gauge at 60°, and miter one end of each board.

7. Place the three boards (B) around the inner triangle and mark

for length. With the miter gauge still set at 60°, tilt the table 14° and cut the opposite end of each board. The undersides should now be longer and wider than the tops.

8. Cut matching spline grooves in each of the boards, identical to those made in step 3. Glue and clamp the boards to the inner triangle.

9. To complete the leg mortises, cut three pieces of stock (C) that measure 1-1/2" x 1-5/8" x 20". Tilt the saw table 5° and bevel one edge of each piece. This bevel matches those made in step 6 on the shorter middle boards (B); the result is that these boards will be wider on the top than on the bottom.

10. Mark the lengths of the three boards from the assembled central section. With the table set at 5° and the miter gauge set at 60°, miter one end of each piece.

11. The final operation on these boards is to bevel the undersides. Tilt the table 30° and, with the 5° beveled side facing up, cut each board so it tapers from 1-1/2" thick on the beveled edge to 3/4" thick on the outside edge.

12. Glue and clamp the boards to the central assembly. When the glue has dried, disc sand the cor-

ners on the underside of the table to match the bevel.

13. Drill a 3/8"-diameter hole 3-1/2" deep through the long middle boards as shown, joint, and glue dowels in place to reinforce the joints.

14. The edge pieces (D) complete the top. Cut the pieces to size, then set the table at 0°. With the miter gauge set at 60°, miter one end of each piece.

15. Tilt the table 15° and bevel the bottom side of each piece, tapering the bottom from 3/4" down to a 1/2" edge.

16. Glue and clamp the edge pieces to the main assembly. With the bandsaw, cut off the corners and disc sand to the final dimension.

17. To make the legs (E), start with three 4"-wide pieces of 1-3/4"-thick stock. Tilt the table to 30° and add just a tapering jig to cut a 2-1/2" taper on a 20"-long piece of stock. Mark an X on the top of each leg, then make one pass on each leg. Use a push stick for this to keep the wood secure.

18. Flip the stock over end for end; the X should now be on the underside of the legs. Move the rip fence about 1/2" closer to the blade; the triangle formed by the saw kerf and the blade should be 3/4" on each side.

19. Cut the remaining tapers, then test-fit the legs in the mortises. Mark the legs where they come through the bottom of the tabletop, then remove them. With the miter gauge set at 14°, disc sand the legs to equal length.

20. Apply glue to the legs and the mortises, then tap the legs in place. Cut off the top remainder of the legs with a handsaw.

21. Belt sand the top to make the tabletop surface flush. Finish as desired.

1/4" WIDE x 1/2" DEEP SPLINE GROOVE

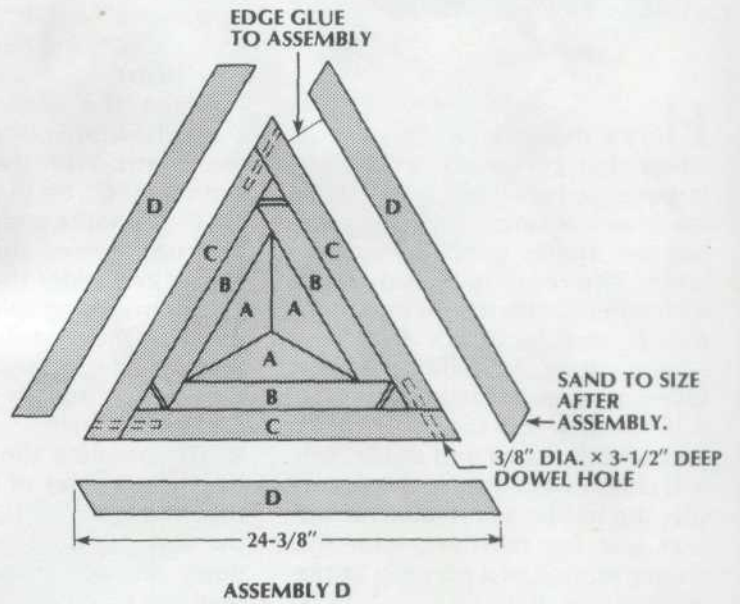
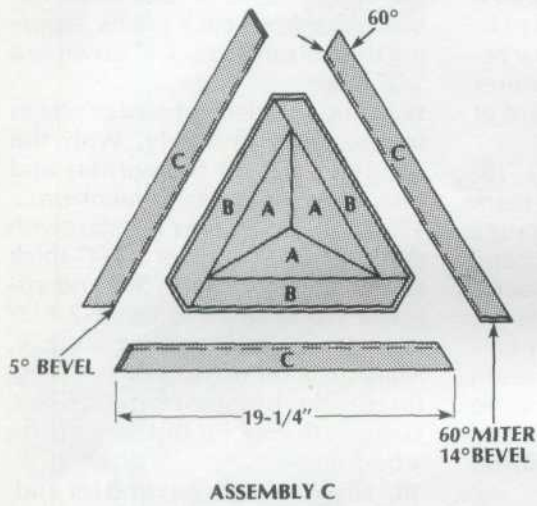
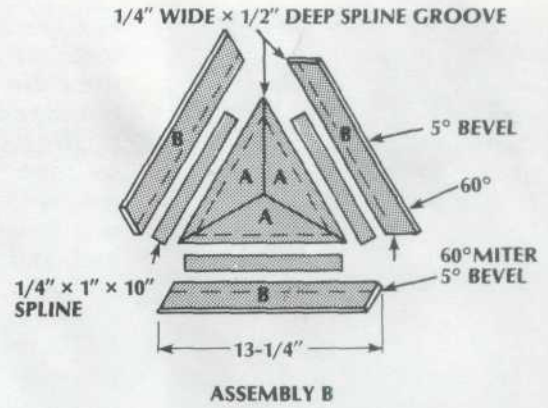
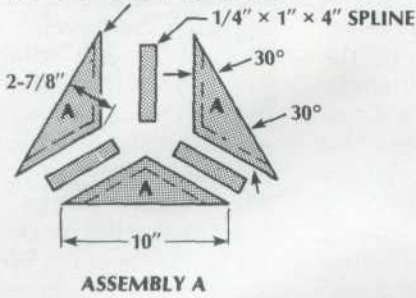

FINAL ASSEMBLY DETAIL

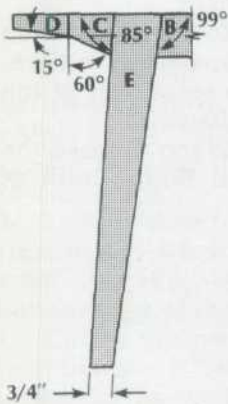
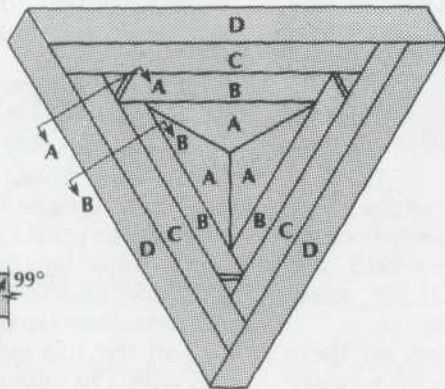

SECTION A-A

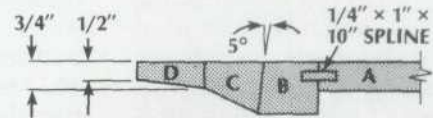

SECTION B-B

### LIST OF MATERIALS

(finished dimensions in inches)

A	Top, inside pieces (3)	3/4 x 2-7/8 x 10
B	Top, middle pieces (3)	1-1/2 x 1-3/4 x 13-1/4
C	Top, middle pieces (3)	1-1/2 x 1-5/8 x 19-1/4
D	Top, edge pieces (3)	3/4 x 2 x 24-3/8
E	Legs (3)	1-3/4 x 2 x 16
	Dowels (3)	3/8 dia. x 3-1/2
	Spline material	1/4 x 1 x 42 tempered hardboard
	Wood glue	



Glue and clamp triangles together.

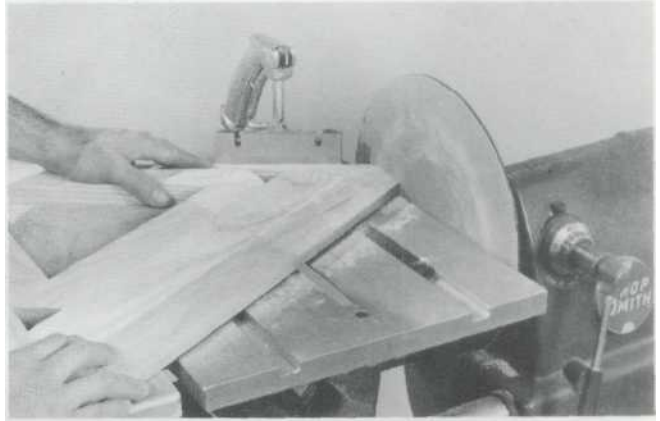

With bandsaw, cut off corners and disc sand to final dimension.

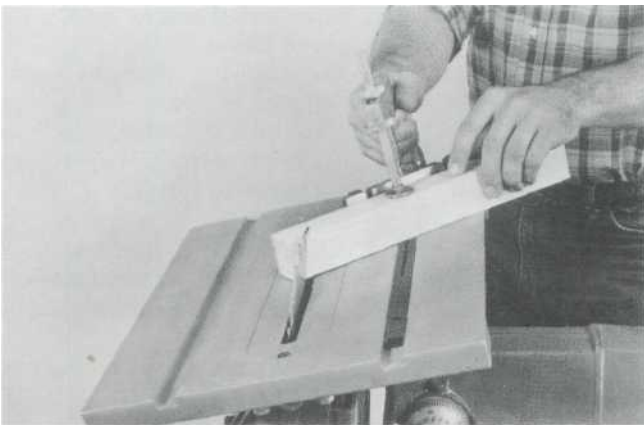

With miter gauge set at  $60^\circ$ , tilt table  $14^\circ$  and cut other end of each part. (Saw guard removed for clarity only.)

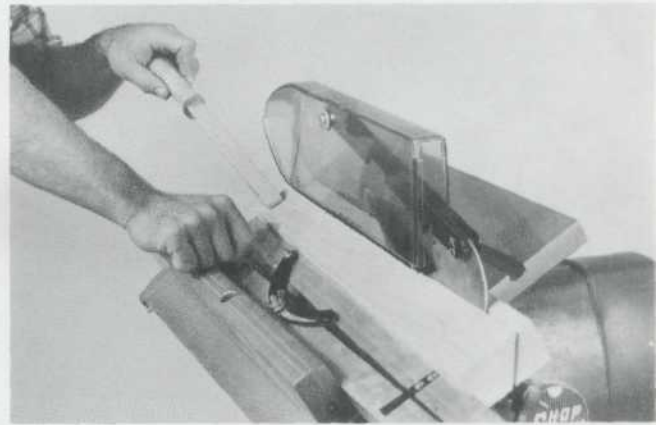

Make one pass on each leg.

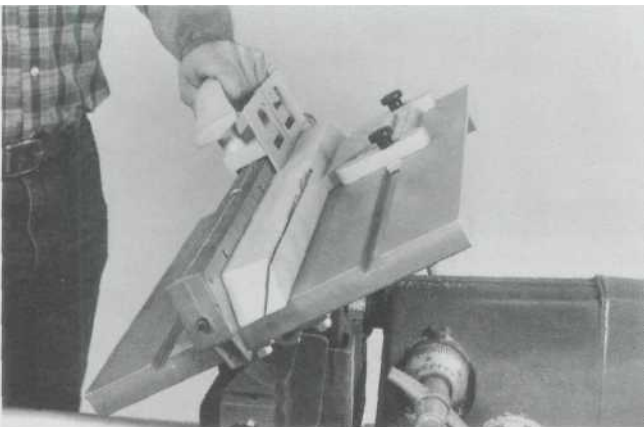

Cut stock so it tapers from  $1\text{-}1/2$ " thick on beveled edge to  $3/4$ " thick on outside edge. (Saw guard removed for clarity only.)

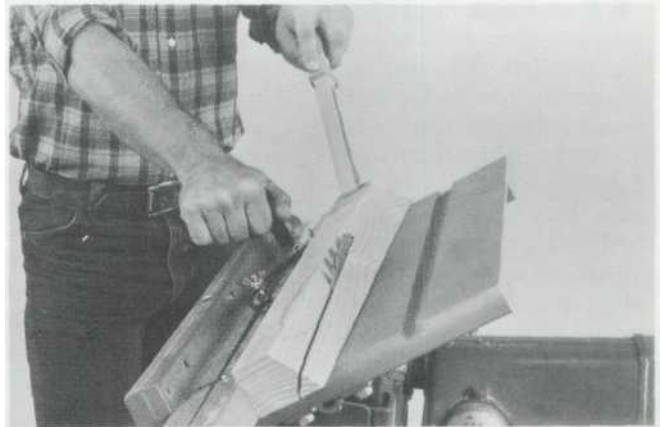

Triangle formed by saw kerf and blade should be  $3/4$ " on each side. (Saw guard removed for clarity only.)