



Wow! I Made It.com

Pine Bed Headboard and Footboard

This great-looking pine bed is similar to one that we found in a furniture store. The big difference is the price. We made the headboard and footboard of ordinary pine and then attached them to a standard metal bed frame. We are proud of the result and even more proud of the money we saved.



Materials

The materials specified are for a queen-size headboard and the footboard. If your bed is larger or smaller, the materials must be adjusted accordingly. See the Cutting List note specifying sizes adjusted for twin-and King-size beds.

- 75 linear feet of 1 x 4 pine
- 20 linear feet of 2 x 4 pine
- 2 linear feet of 2 x 6 pine

Hardware

- 110 1-1/4" 3d finishing nails
- 100 1-1/2" 4d finishing nails
- 16 2-1/2" 8d finishing nails
- 16 2" screws

Special Tools and Techniques

- Pipe clamps
- Dadoes

Cutting List

Code	Description	Qty.	Materials	Dimensions
A	Headboard Top/Bottom	2	2 x 4 pine	56" long
B	Headboard Slat	16	1 x 4 pine	10" long
C	Headboard Post Vertical	8	1 x 4 pine	41-1/2" long
D	Headboard Post Cap	2	2 x 6 pine	5-1/2" long
E	Footboard Top/Bottom	2	2 x 4 pine	56" long
F	Footboard Slat	16	1 x 4 pine	8-1/2" long
G	Footboard Post Vertical	8	1 x 4 pine	25-1/2" long
H	Footboard Post Cap	2	2 x 6 pine	5-1/2" long

**** Cutting List Notes**

For a twin-size bed, the headboard top/bottoms (A) and the footboard top/bottoms (E) should be 35 inches long, and you will need 10 headboard slats (B) and 10 footboard slats (F). Instead of the materials listed, you will need only 65 linear feet of 1 x 4 pine and 14 linear feet of 2 x 4 pine.

For a king-size bed, the headboard top/bottoms (A) and the footboard top/bottoms (E) should be 73-1/2 inches long, and you will need 21 headboard slats (B) and 21 footboard slats (F). Therefore, you will need 84 linear feet of 1 x 4 pine and 26 linear feet of 2 x 4 pine.

Making the Headboard

1. Cut two headboard top/bottoms (A) from 2 x 4 pine, each measuring 56 inches long.
2. Cut a 3/4-inch-wide dado, 1/2-inch deep down the length of one edge of each of the headboard top/bottoms (A), as shown in *Figure 1*.

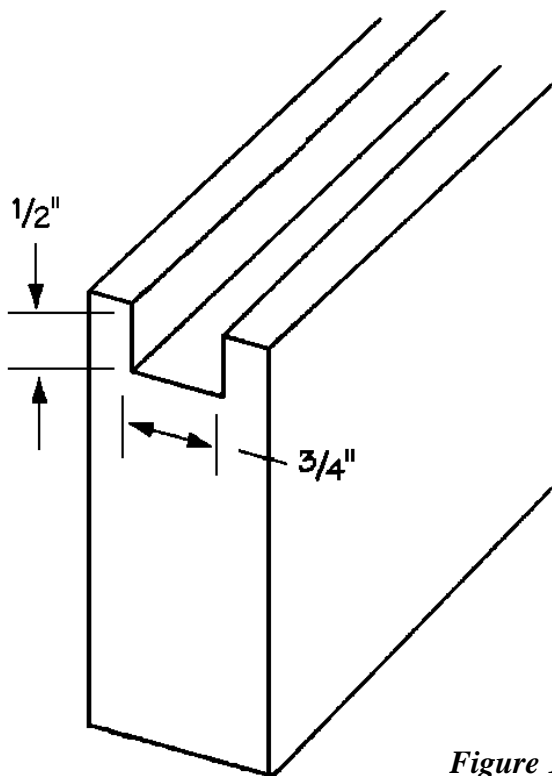

Figure 1

3. Cut sixteen headboard slats (B) from 1 x 4 pine, each measuring 10 inches long.
4. Working on a level surface, place the two headboard top/bottoms (A) parallel to each other, with the dados to the inside, as shown in *Figure 2*. Fit the ends of the sixteen headboard slats (B) into the dados in the headboard top/bottoms (A). When the headboard slats are properly fitted, the distance between the two headboard top/bottoms should measure 9 inches. When the positions are perfect, the overall measurement of the headboard assembly should be 16 inches high and 56 inches long. Secure the slats by nailing through the dadoed edge of the headboard top/bottoms (A) into the ends of the headboard slats (B) using two 1-1/4-inch-long nails on each joint.

Adding the Headboard Posters

1. Cut eight headboard poster verticals (C) from 1 x 4 pine, each measuring 41-1/2 inches long.

- In order to center the completed headboard posters, the first headboard poster vertical (C) must be offset when it is attached to the headboard assembly. Refer to *Figure 3* to mark the placement of the headboard assembly on the first headboard poster vertical (C).

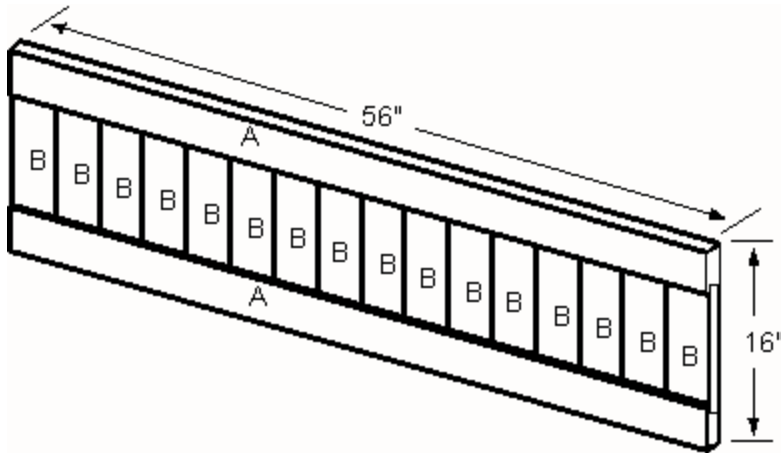

Figure 2

- Repeat Step 2 to mark a mirror image placement on a second headboard poster vertical (C).
- Position the headboard assembly between the marked verticals (C), exactly on the placement marks. Wipe glue on the meeting surfaces, and use clamps to hold the assembly together. Screw through the verticals (C) into the ends of the headboard top/bottom (A) using two 2-inch-long screws on each joint.

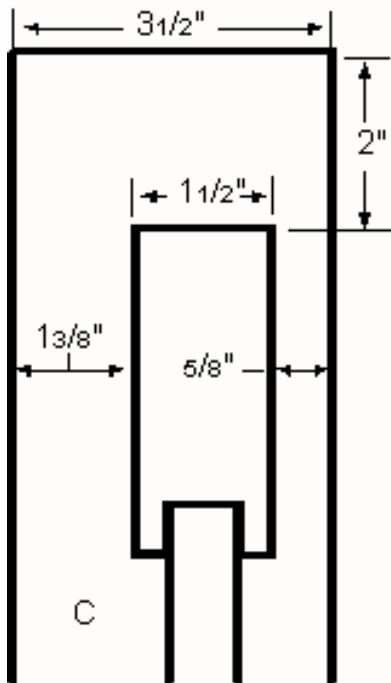

Figure 3

- Add three more verticals (C) to each of the attached verticals (C), overlapping each piece in rotation, as shown in *Figure 5*. Secure each of the verticals (C) with glue and 1-1/2" long nails spaced every 4 inches along the length. Make certain that you follow the rotation exactly to form the first poster, and then rotate the opposing poster in a mirror image; otherwise, your posters will not match.
- Cut two headboard poster caps (D) from 2 x 6 pine, each measuring 5-1/2" long.
- Center one headboard poster cap (D) over one assembled poster. Wipe glue on the meeting surfaces, and nail through the headboard poster cap (D) into each of the verticals (C) using four 2-1/2"-long nails.
- Repeat Step 7 to attach the remaining headboard poster cap (D) to the remaining poster.

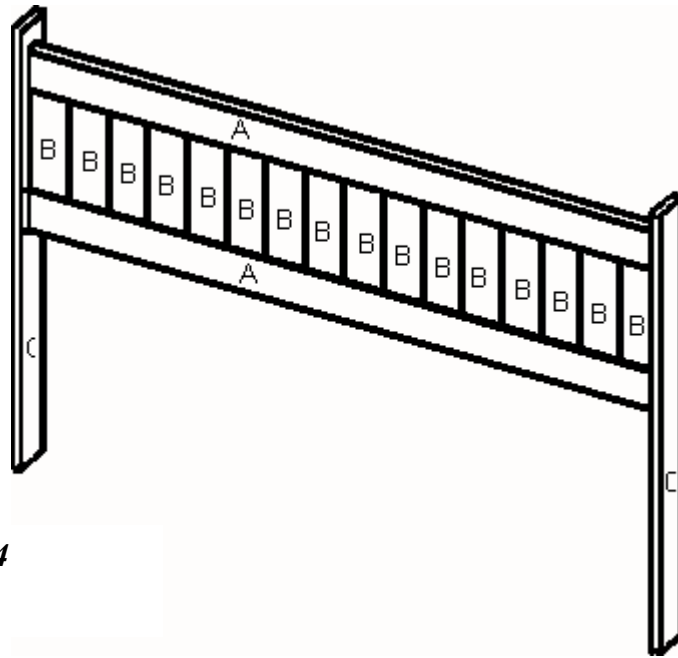

Figure 4

Making the Footboard

1. Cut two footboard top/bottoms (E) from 2 x 4 pine, each measuring 56 inches long.
2. Cut a 3/4-inch-wide dado, 1/2-inch-deep down the length of one edge of each of the footboard top/bottoms (E), as shown in *Figure 1*.
3. Cut sixteen footboard slats (F) from 1 x 4 pine, each measuring 8-1/2 inches long.
4. Working on a level surface, place the two footboard top/bottoms (E) parallel to each other, with the dados to the inside, in the same manner as shown in *Figure 2*. Fit the ends of the sixteen footboard slats (F) into the dados in the footboard top/bottoms (E). When the footboard slats are properly fitted, the distance between the two footboard top/bottoms should measure 7-1/2 inches. When the positions are perfect, the overall measurement of the footboard assembly should be 14-1/2 inches high and 56 inches long. Secure the slats by nailing through the dadoed edge of the footboard top/bottoms (E) into the ends of the footboard slats (F) using two 1-1/4-inch-long nails on each joint.

Adding the Footboard Posters

1. Cut eight footboard poster verticals (G) from 1 x 4 pine, each measuring 25-1/2" long.
2. In order to center the completed footboard posters, the first footboard poster vertical (G) must be offset when it is attached to the footboard assembly. Refer to *Figure 3* to mark the placement of the footboard assembly on the first footboard poster vertical (G).

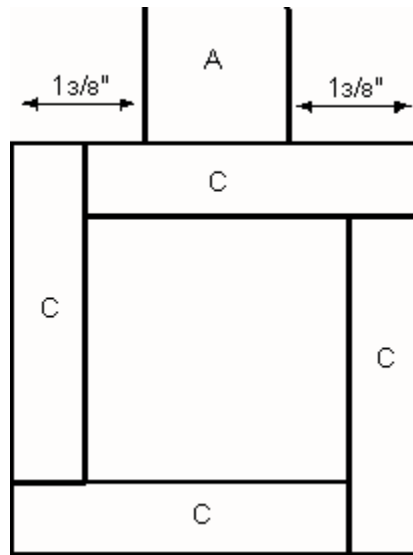

Figure 5

3. Repeat Step 2 to mark a mirror image placement on a second footboard poster vertical (G).
4. Position the footboard assembly between the marked verticals (G), exactly on the placement marks. Wipe glue on the meeting surfaces, and use clamps to hold the assembly together. Screw through the verticals (G) into the ends of the footboard top/bottom (E) using two 2-inch-long screws on each joint.
5. Add three more verticals (G) to each of the attached verticals (G), overlapping each piece in rotation, as shown in *Figure 5*. As you did for the headboard, make certain that you follow the rotation exactly to form the first post, and then reverse the rotation for the other post.
6. Cut two footboard post caps (H) from 2 x 6 pine, each measuring 5-1/2" long.
7. Center one footboard post cap (H) over one assembled post. Nail through the post cap (H) into each of the verticals (G), using four 2-1/2" 8d-finishing nails.
8. Repeat Step 7 to attach the remaining footboard post cap (H) over the remaining post.

Finishing

1. Fill the screw holes, crevices, and cracks with wood filler.
2. Sand all surfaces of the completed headboard and footboard.
3. Stain or paint the headboard and footboard the color of your choice. We chose to retain the natural color of the pine and simply seal it with glossy polyurethane.
4. We already had a metal frame with brackets for both a headboard and footboard, so we simply positioned the headboard and footboard and screwed through the metal brackets into the

posts on both the headboard and footboard. If your frame has only one bracket, you can turn the frame around and attach that bracket to the footboard. Then you can either attach the headboard to the wall or simply place the headboard against the wall and push the bed against it to hold it in place.

**Need a night stand for your bed? How about a fern pedestal?
Many more projects are available from .**

