

Garage Workbench Plans



Every home woodworker knows the importance of making efficient use of the available space in his or her shop. This workbench is designed to provide the maximum functionality using the minimum amount of space possible. It provides a work surface of about six feet by two feet and is about 35" in height. Just the right size to provide ample work space for most projects.

The features that make this workbench ideal for the home shop are the built in clamping system, the built in router table, the nine drawers, the center cabinet space, and the mobility. The four inch casters enable you to easily roll it into position when needed and roll it aside when it is not in use.

The top surface is made of two layers of 3/4" MDF. This provides an extremely flat work surface and since it is also a router table, a flat work surface is a must. The T-track inlaid in the top and around the edges makes the entire work surface a versatile clamping system that easily clamps very small or very large work pieces.

Table of Contents - 1

Dimensions Drawings

Materials List - 1	x
Materials List - 2	x
End and Center Panels	1
Base Dimensions & Layout	2
Back Dimensions & Layout	3
Top Dimensions & Layout	4
Sub Top Dimensions & Layout	5
Top Trim and T-Track	6
Drawer Slides, Stiffener, Misc. Small Parts	7
Drawer Fronts, Front Trim, and Doors	8
Drawer Boxes Dimensions	9
Router Bit Trays	10
Middle Shelf	11

Table of Contents - 2

Assembly Instructions

Drawer Slides - Left Section - Left Panel	12
Drawer Slides - Left Section - Right Panel	13
Drawer Slides - Center Section - Left Panel	14
Drawer Slides - Center Section -Right Panel	15
Drawer Slides - Right Section - Left Panel	16
Drawer Slides - Right Section - Right Panel	17
Base to Panels	18
Stiffener - Casters	19
Attach the Back	20
Router Box Bottom & Shelf	21
Router Box Front	22
Assemble the Face Frame	23
Attach the Face Frame	24
Attach the Leveling Blocks to the Panels	25
Attach the Front & Rear Leveling Blocks	26
Attach the Sub Top	27
Attach the Inner Trim	28
Attach the Middle Trim	29
Attach the Top	30
Attach the Track to the Top	31
Attach the Track to the Front & Ends	32
Attach the Lower Trim	33
Assemble the Drawer Boxes & Fronts	34
Assemble the Router Trays	35
Attach Cabinet Doors	36
Attach Middle Door trim	37
Clamping System Parts	38
Assemble the EZ Mount Stop	39
Clamping System Usage Instructions	40
Clamping System Illustrations	41
Snapshots	42

Materials List - 1

Qty	Size	Material	Item name
2	29 1/4" by 19"	3/4" Oak Plywood	End Panels
2	28 1/4" by 18 1/4"	3/4" Plywood	Middle Panels
1	66 1/2" by 19"	3/4" Plywood	Base
1	66 1/2" by 28 1/4"	3/4" Plywood	Back
1	72" by 24"	3/4" MDF Board	Top
1	68" by 19 3/4"	3/4" MDF Board	Sub Top
2	69 1/2" by 1 1/2"	3/4" Wood or Plywood	1st Front & Back Sub Top Trim
2	21 1/4" " by 1 1/2"	3/4" Wood or Plywood	1st End Sub Top Trim
2	71" by 1 1/2"	3/4" Wood or Plywood	2nd Front & Back Sub Top Trim
2	22 3/4" by 1 1/2"	3/4" Wood or Plywood	2nd End Sub Top Trim
2	36"	1/2" by 3/4" T-Track	Front T-Track
5	24"	1/2" by 3/4" T-Track	End & Top T-Track
1	72" by 3/4" by 1/2"	1/2" Thick MDF or Wood	Front Lower T-Track Trim
2	24" by 3/4" by 1/2"	1/2" Thick MDF or Wood	End Lower T-Track Trim
17	18 1/4" by 1 1/2"	3/4" Wood	Drawer Supports
5	6" by 1 1/2"	3/4" Wood	Small Drawer Supports
10	18 1/4" by 2 1/2"	3/4" Wood	Drawer Side Guides
2	6" by 2 1/2"	3/4" Wood	Small Drawer Side Guides
4	18 1/4" by 3"	3/4" Wood	Lower Drawer Side Guides
6	18 1/4" by 2"	3/4" Wood	Lower Drawer Supports
2	14 1/2" by 2"	3/4" Wood	Lower Back Supports
1	27 1/2" by 2"	3/4" Wood	Center Lower Back Support
4	17 1/2" by 1 1/2"	3/4" Wood	17 1/2" Leveling Block
3	16 3/4" by 1 1/2"	3/4" Wood	16 3/4" Leveling Block
2	30" by 1 1/2"	3/4" Wood	30" Leveling Block
1	10 1/4" by 1 1/2"	3/4" Wood	10 1/4" Leveling Block
1	66 1/2"	2 by 4 (3 1/2" by 1 1/2")	Stiffener
6	16" by 1 1/2"	3/4" thick wood or plywood	Drawer Trim
2	29 1/4" by 1 1/2"	3/4" thick wood or plywood	Vertical End Trim
1	30" by 1 1/2"	3/4" thick wood or plywood	Middel Trim

Materials List - 2

Qty	Size	Material	Item name
2	23 1/4" by 1 1/2"	3/4" thick wood or plywood	Vertical Divider Trim
2	65" by 3"	3/4" thick wood or plywood	Upper & Lower Trim
1	3 1/2" by 30 1/2"	3/4" thick wood or plywood	Center Drawer Front
2	3 1/2" by 16 1/2"	3/4" thick wood or plywood	Top Drawer Front
2	4 1/2" by 16 1/2"	3/4" thick wood or plywood	4 1/2" Drawer Front
2	5 1/4" by 16 1/2"	3/4" thick wood or plywood	5 1/4" Drawer Front
2	7" by 16 1/2"	3/4" thick wood or plywood	7" Drawer Front
2	19" by 14 3/4"	3/4" thick wood or plywood	Cabinet Doors
1		3/4" thick wood or plywood	Door Lip
1	17 1/2" by 11 1/2"	3/4" thick wood or plywood	Router Box Front
6	19" by 2 7/8"	3/4" thick wood or plywood	Top Drawer Sides
4	19" by 3 7/8"	3/4" thick wood or plywood	3 7/8" Drawer Sides
4	19" by 4 7/8"	3/4" thick wood or plywood	4 7/8" Drawer Sides
4	19" by 6 5/8"	3/4" thick wood or plywood	6 5/8" Drawer Sides
2	28 3/8" by 2 7/8"	3/4" thick wood or plywood	Center Drawer Ends
4	14 3/8" by 2 7/8"	3/4" thick wood or plywood	Top Drawer Ends
4	14 3/8" by 3 7/8"	3/4" thick wood or plywood	3 7/8" Drawer Ends
4	14 3/8" by 4 7/8"	3/4" thick wood or plywood	4 7/8" Drawer Ends
4	14 3/8" by 6 5/8"	3/4" thick wood or plywood	6 5/8" Drawer Ends
1	29 1/8" by 18 1/4"	1/4" Hardboard	Center Drawer Bottom
6	15 1/8" by 18 1/4"	1/4" Hardboard	Drawer Bottom
2	6" by 2 7/8"	3/4" thick wood or plywood	Top Router Tray Sides
2	6" by 3 7/8"	3/4" thick wood or plywood	2nd Router Bit Trays
2	14 7/8" by 6"	1/2" thick material	Router Bit Trays
2	14 7/8" by 6"	1/4" thick material	Router Bit Bottoms
1	18 1/4" by 30"	3/4" plywood	Middle Shelf

End and Center Panels

Page 1

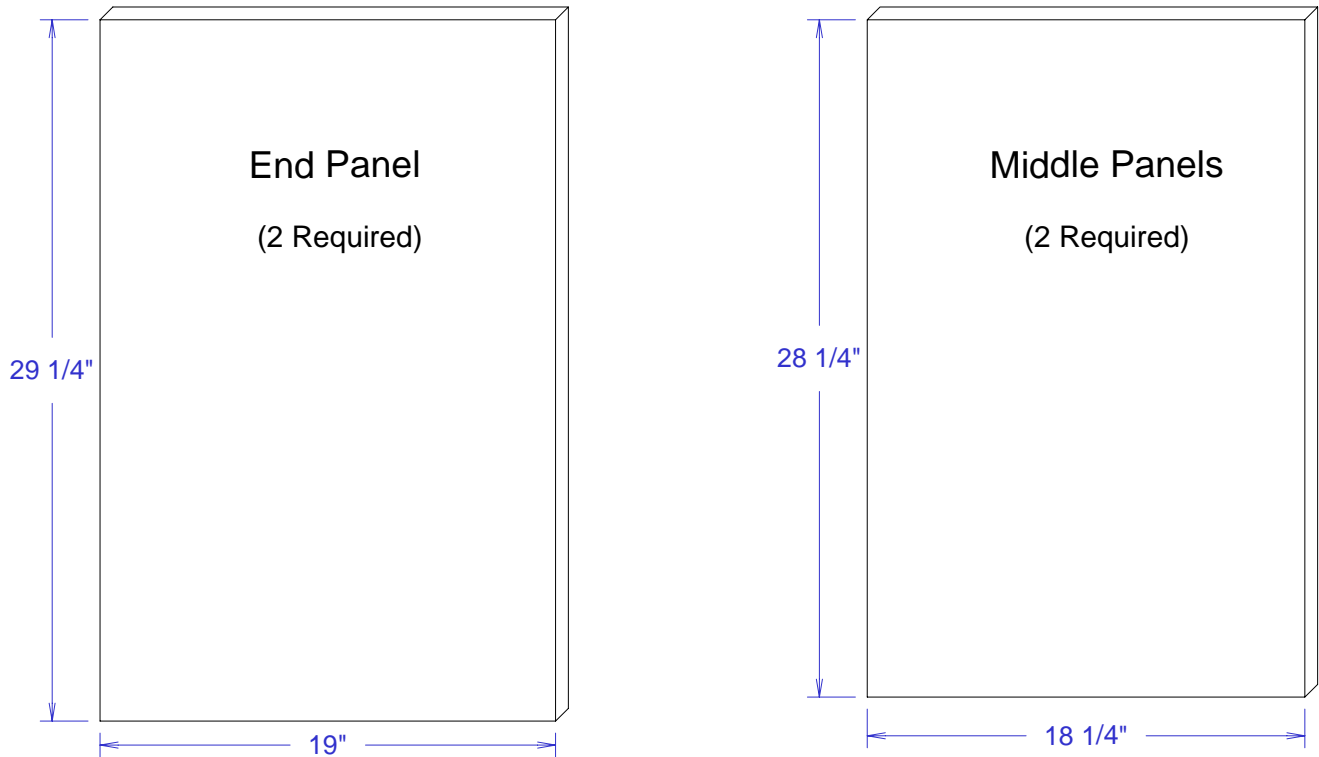

The two end panels are 1" taller than the center panels. This is because the center panels sit on the top surface of the base and the end panels extend 1/4" below the bottom surface of the base..

The end panels are also 3/4" wider than the center panels. This is so they will be flush with the ends of the back section.

Base Dimensions & Layout

Page 2

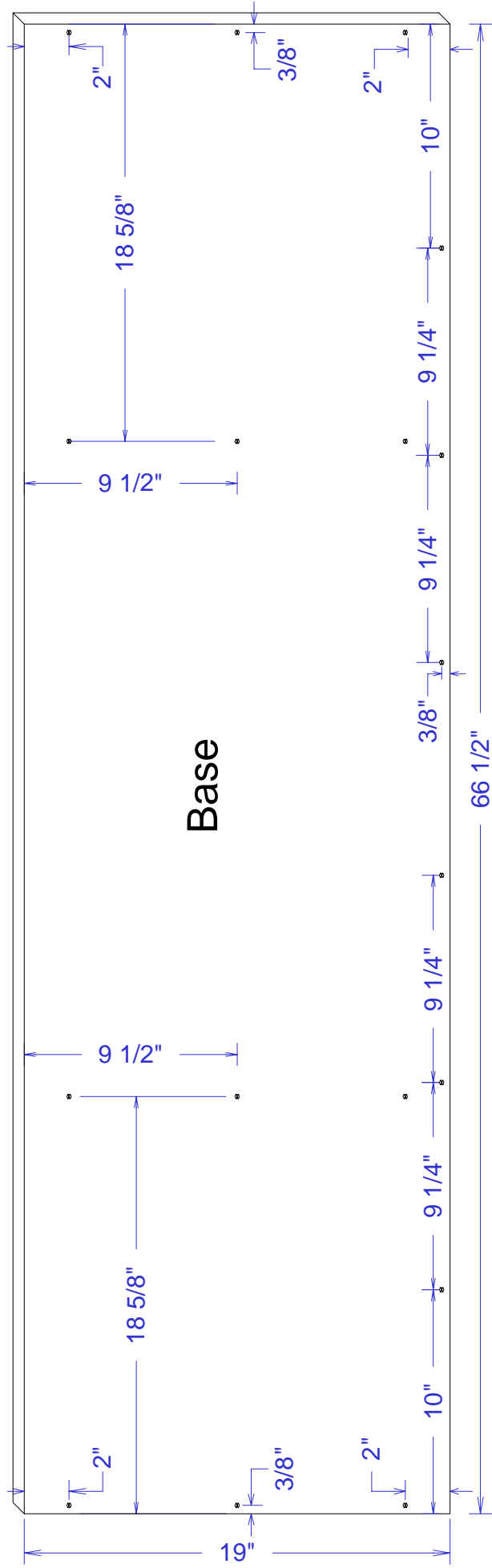

Cut the base from 3/4" material, then drill and countersink holes for #8 screws as shown in the drawing above. All the screws around the edge are 3/8" from the edge.

Back Dimensions & Layout

Page 3

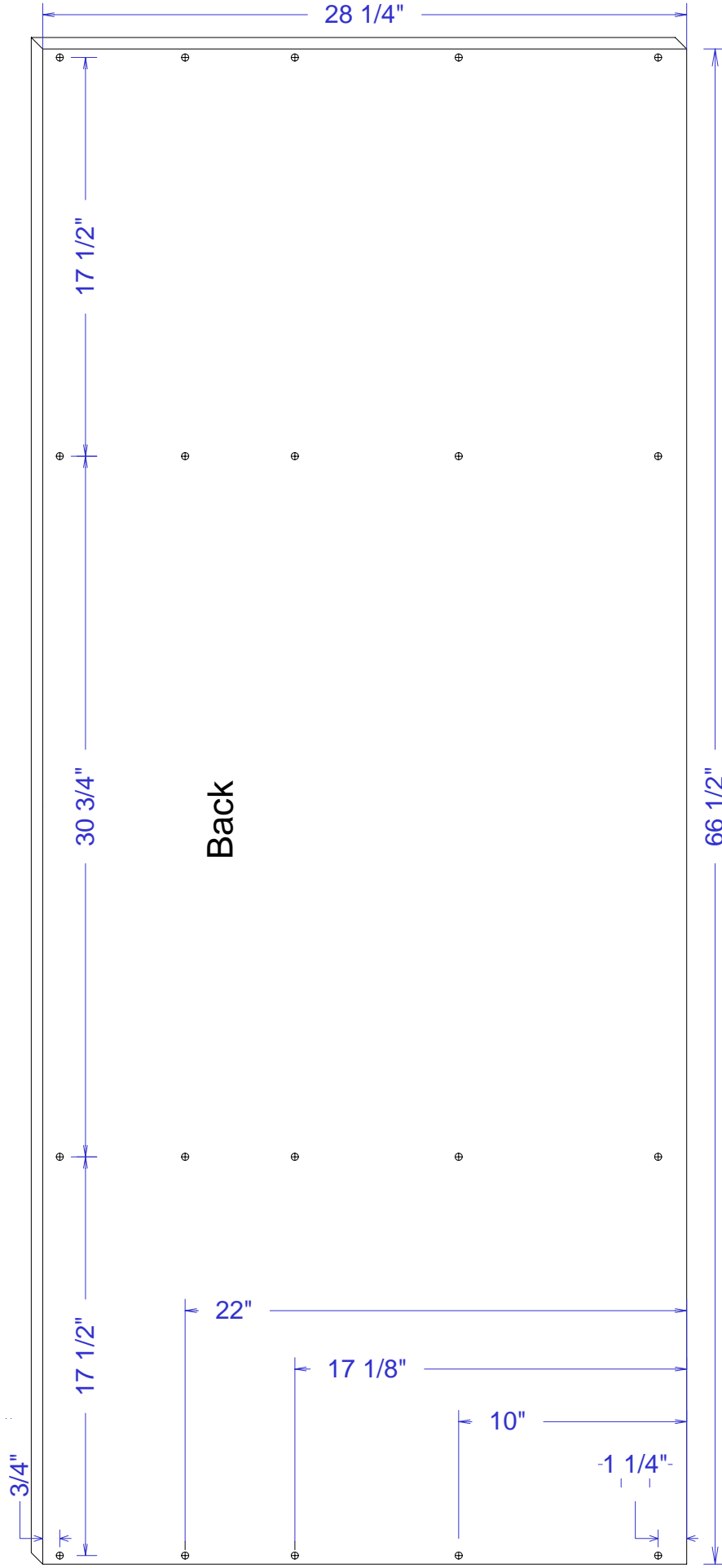

Cut the back from $3/4$ " material, then drill and countersink holes for #8 screws as shown in the drawing above.

Router Plate Cutout

This drawing is based on a 9 1/4" by 11 3/4" router plate. If you are using a different size plate, **you will need to adjust the size of the opening accordingly**. The router plate opening is a two step process. You must cut an inner opening that leaves room for a 3/4" wide lip around all four edges. This lip is what the router plate rests upon.

First, cut the inner opening completely through the top. If you're using a 9 1/4" by 11 3/4" router plate, this inner opening should be 7 3/4" by 10 1/4". The next step is to use your router to create the lip around the sides of the opening. See the detailed instructions on the following page for this step.

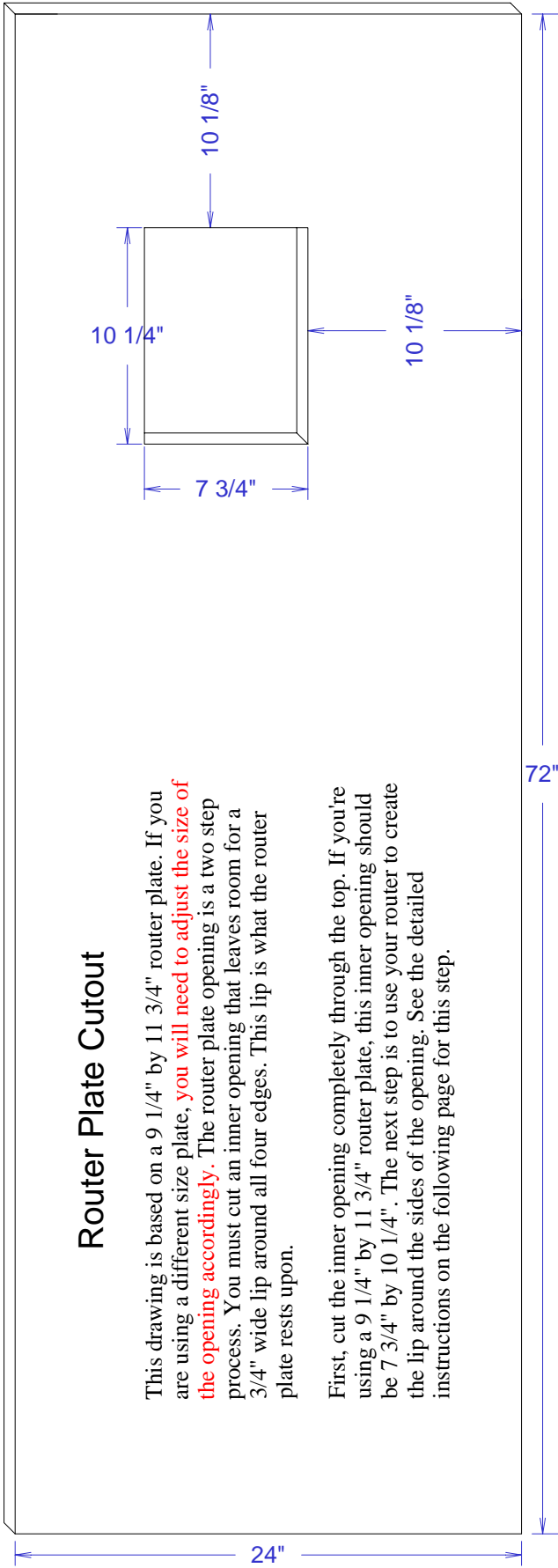

T-Track & Miter Slot Cutout Dimensions

T-Track Slot

T-Track sizes vary from brand to brand. The most common sizes are 3/4" wide by 1/2" deep or 3/4" wide by 3/8" deep. Cut the slots so the track you're using is flush with the top surface.

The T-Track and miter gauge slot dimensions are based on the center of the slots. However, the exact location of these items is strictly a matter of personal choice.

If you will be using a readymade router fence, you may need to change the spacing of the fence track slots to match your fence.

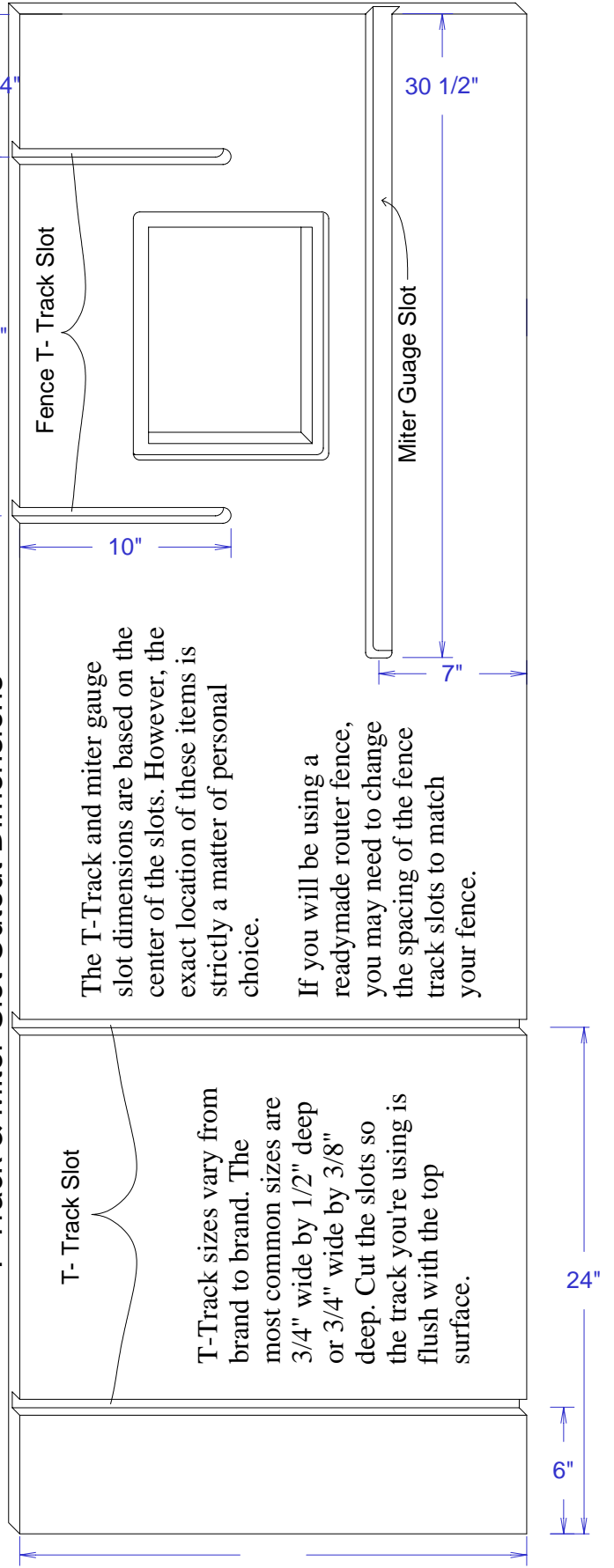

Sub Top Dimensions and Layout

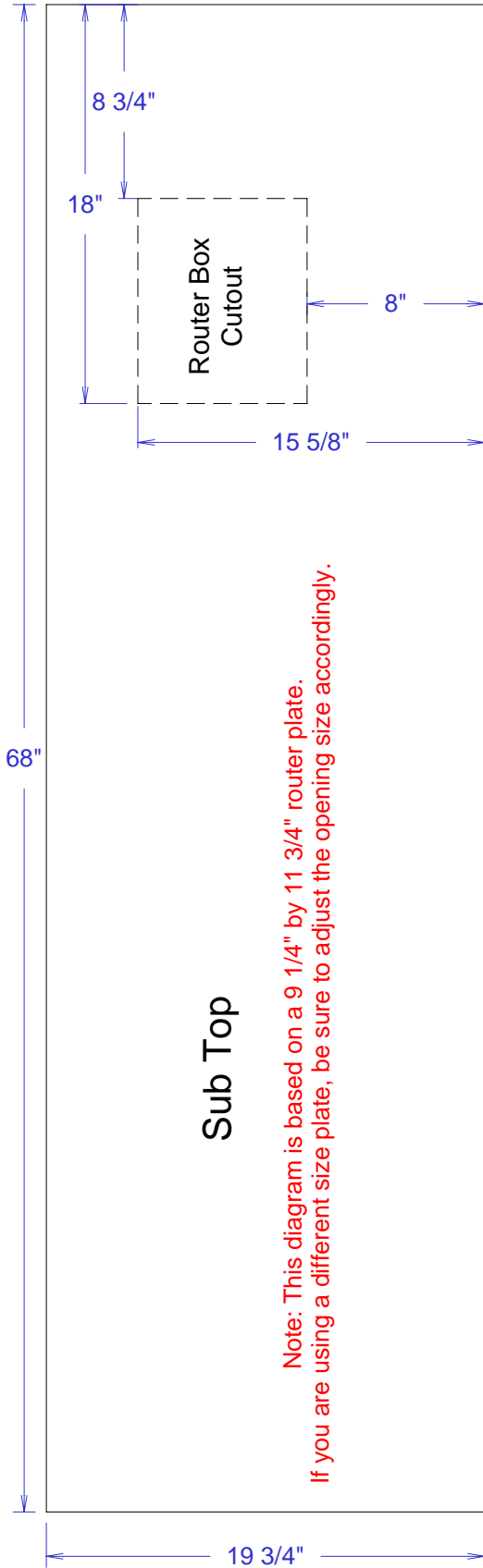

Note: This diagram is based on a 9 1/4" by 11 3/4" router plate.
If you are using a different size plate, be sure to adjust the opening size accordingly.

Drill and counter screwholes for #8 flathead screws in the locations shown below.

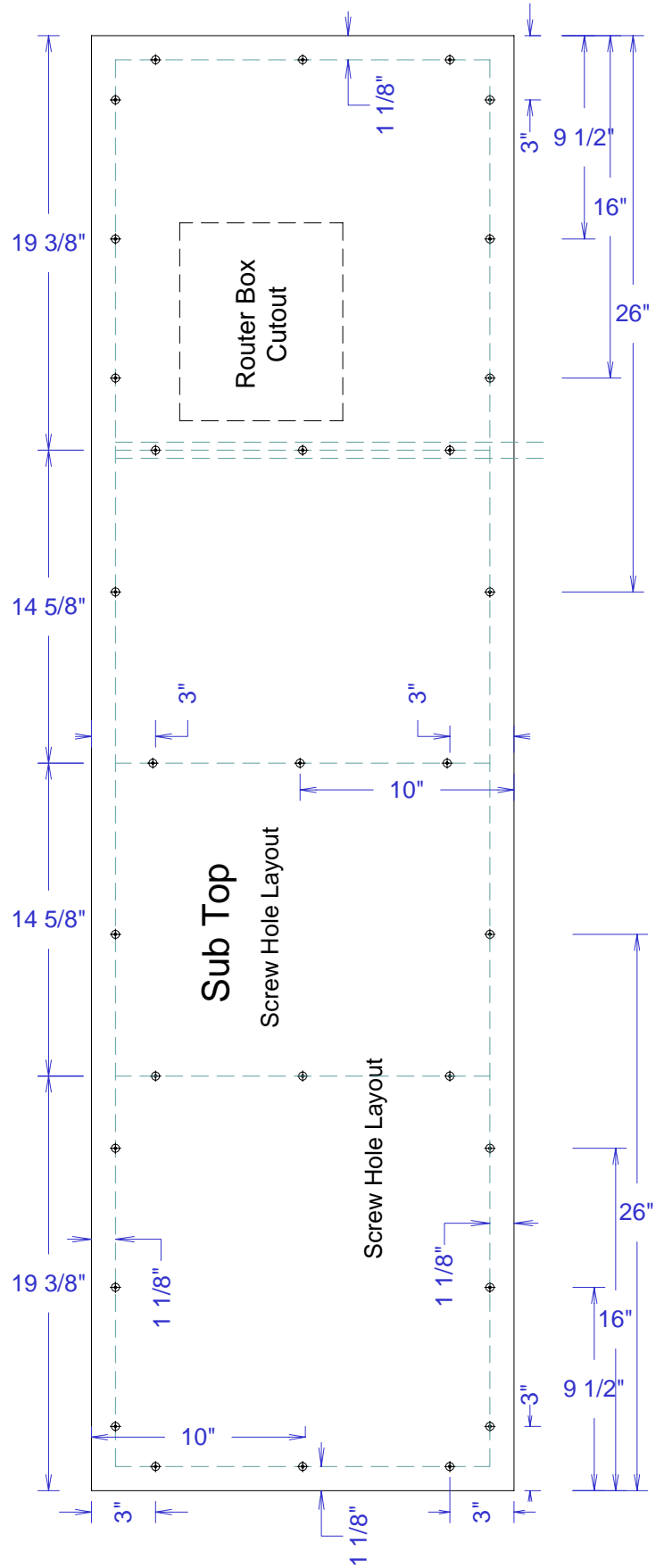

Top Trim & T-Track

Page 6

The Sub Top trim is made of 3/4" thick by 1 1/2" high material. This because the T-Track is 1/2" by 3/4" .

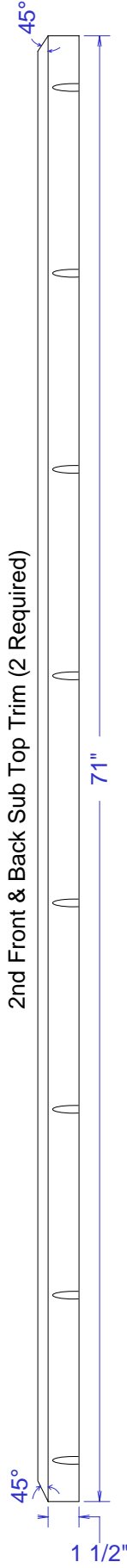
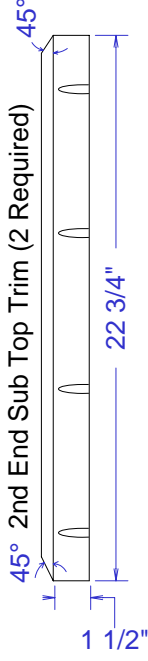
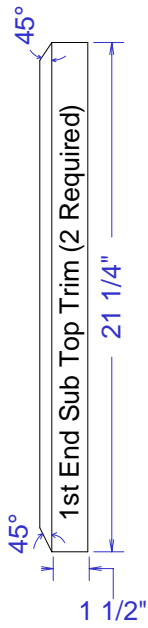
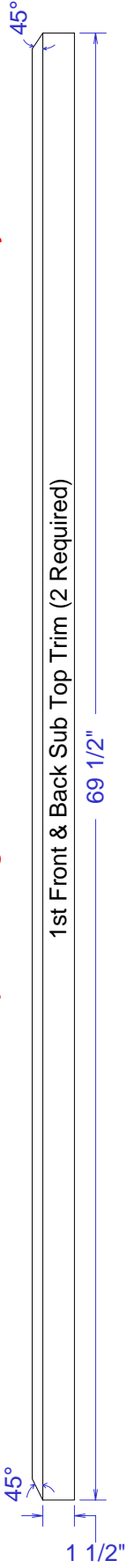

If you have a pocket hole jig, I recommend drilling pocket holes in the 2nd Sub Top Trim pieces as shown. These pocket holes will be used to secure the Top to the Sub Top. The exact location of the pocket holes is not critical. The important thing is that they do not line up with the screw holes in your T-Track. If you do not have a pocket hole jig, the Top can be secured with finishing nails or glue.

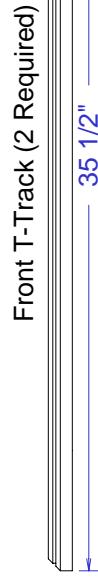

The T-Track trim is made of 1/2" thick by 3/4" high material. This because the T-Track is 1/2" by 3/4" .

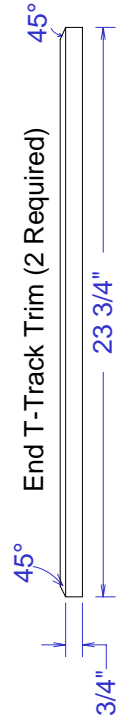
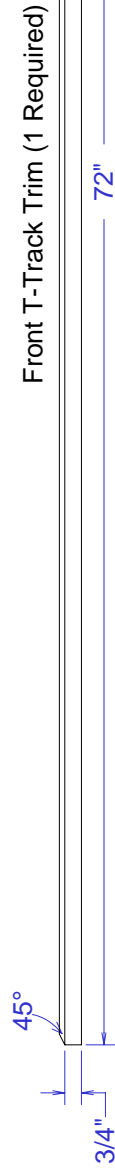

Drawer Slides / Stiffener / Misc Small Parts

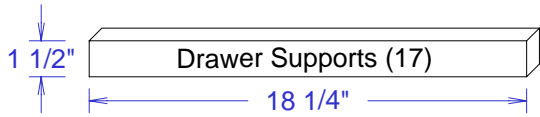

Small Drawer Supports (5)

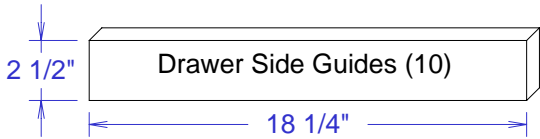
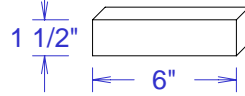

Small Drawer Side Guides (2)

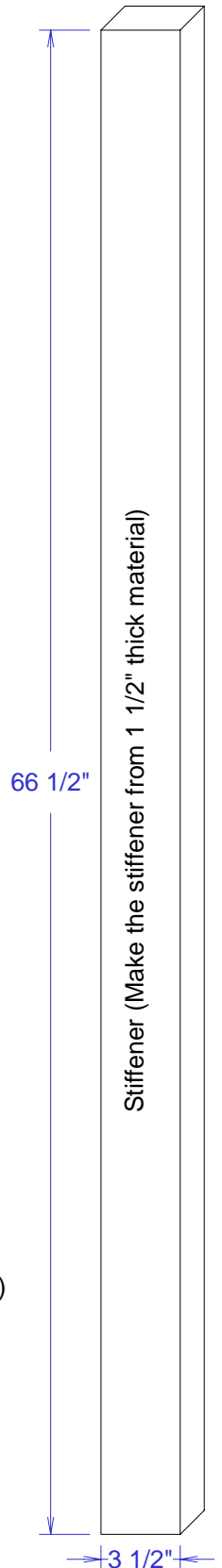
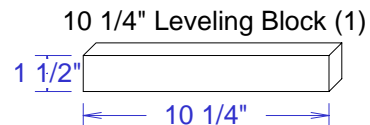
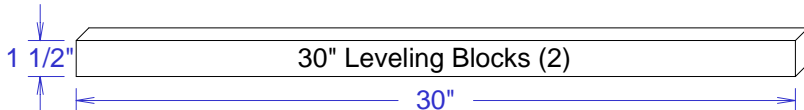
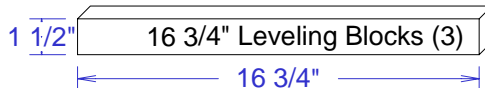
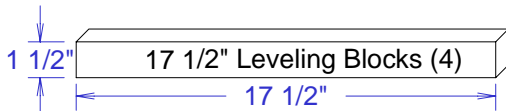
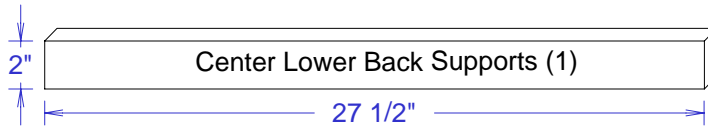
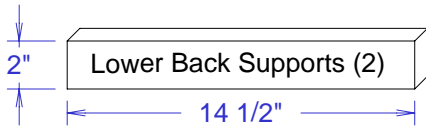
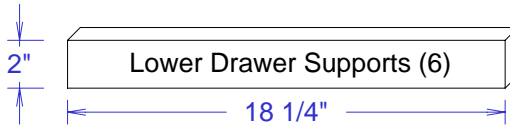
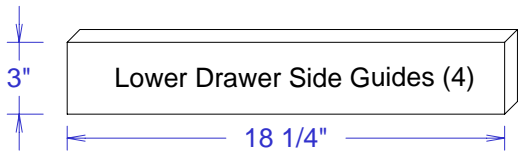
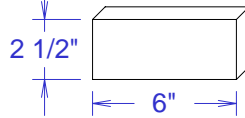

Drawer Fronts, Front Trim, and Doors

Page 8

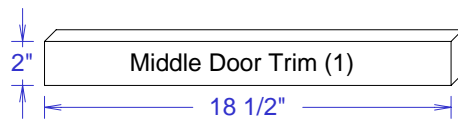
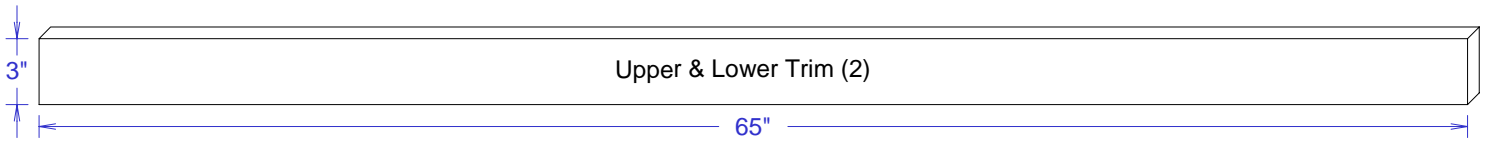
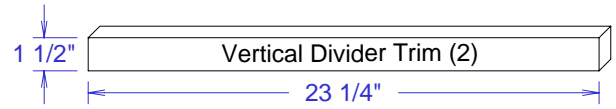
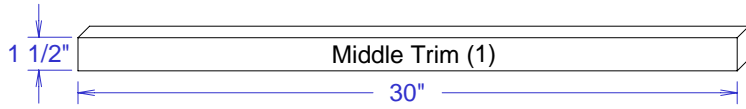
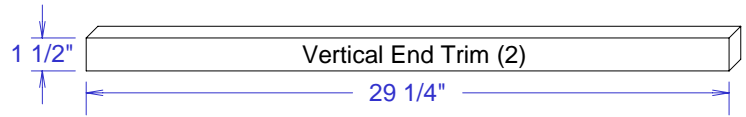
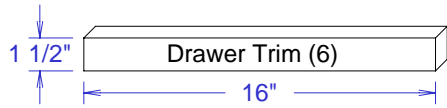

Drawer Fronts Dimensions

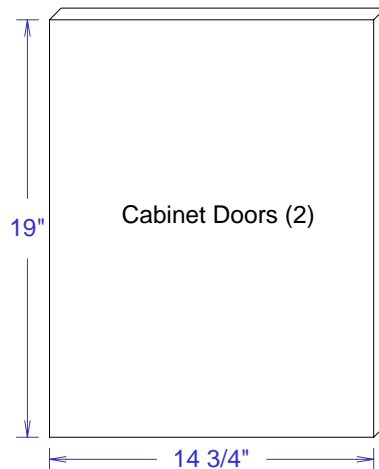
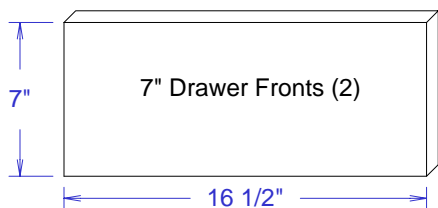
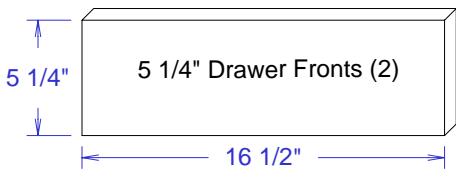
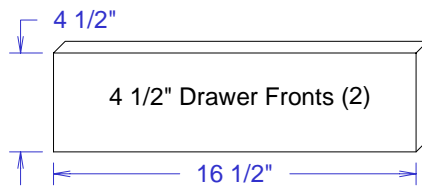
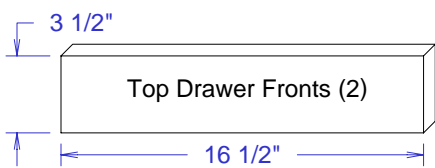
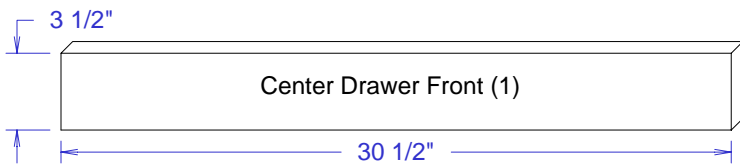

Router Box Dimensions

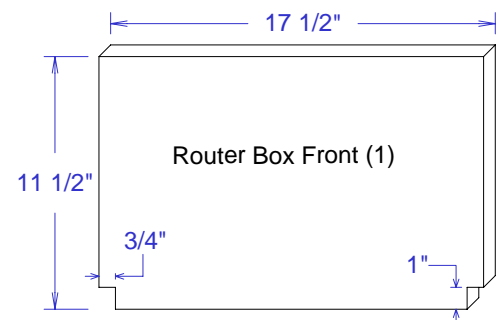
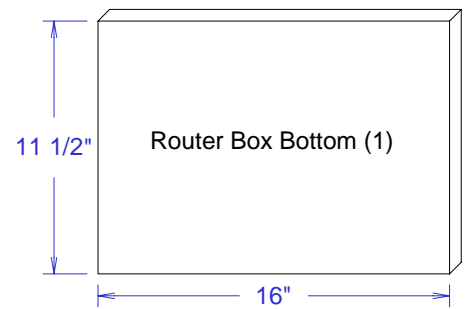

Drawer Boxes Dimensions

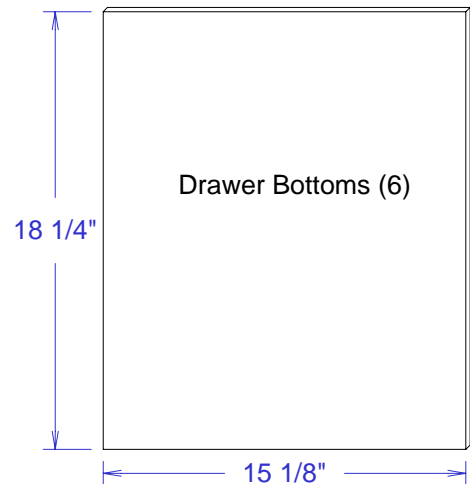
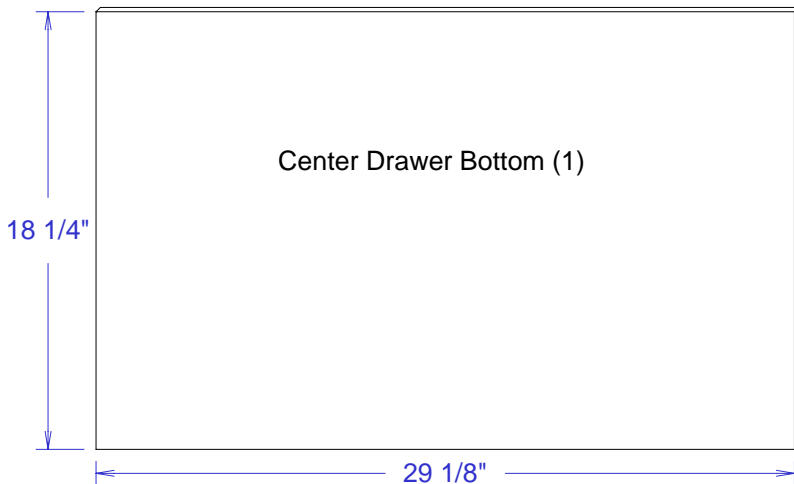
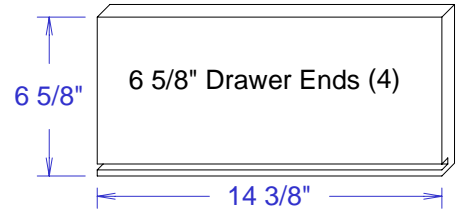
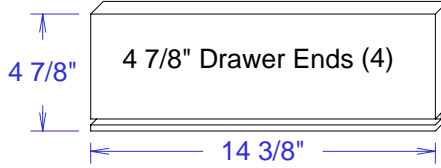
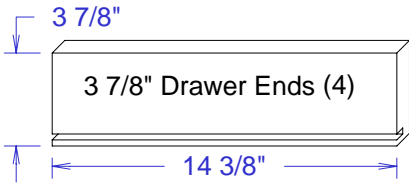
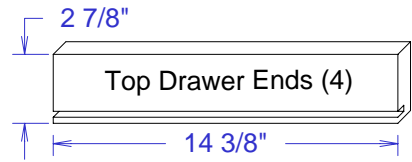
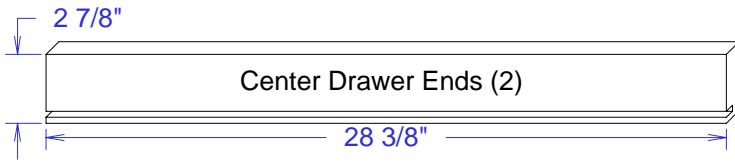
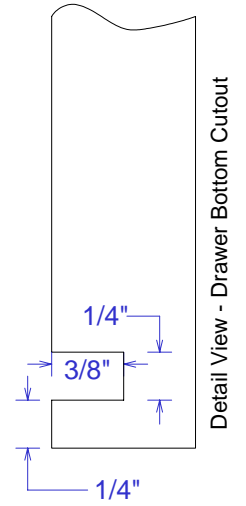
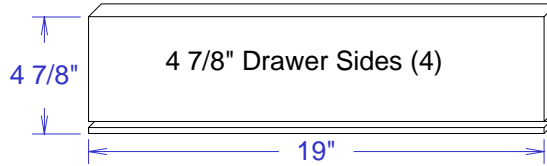
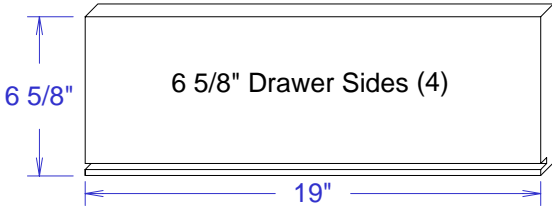
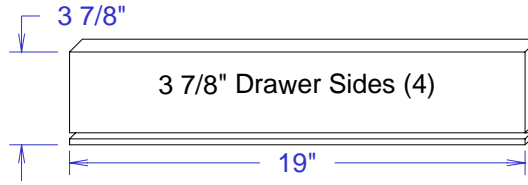
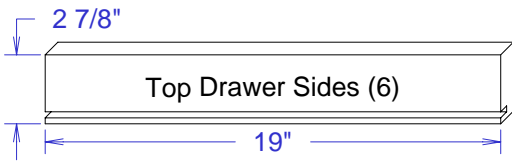

Router Bit Trays

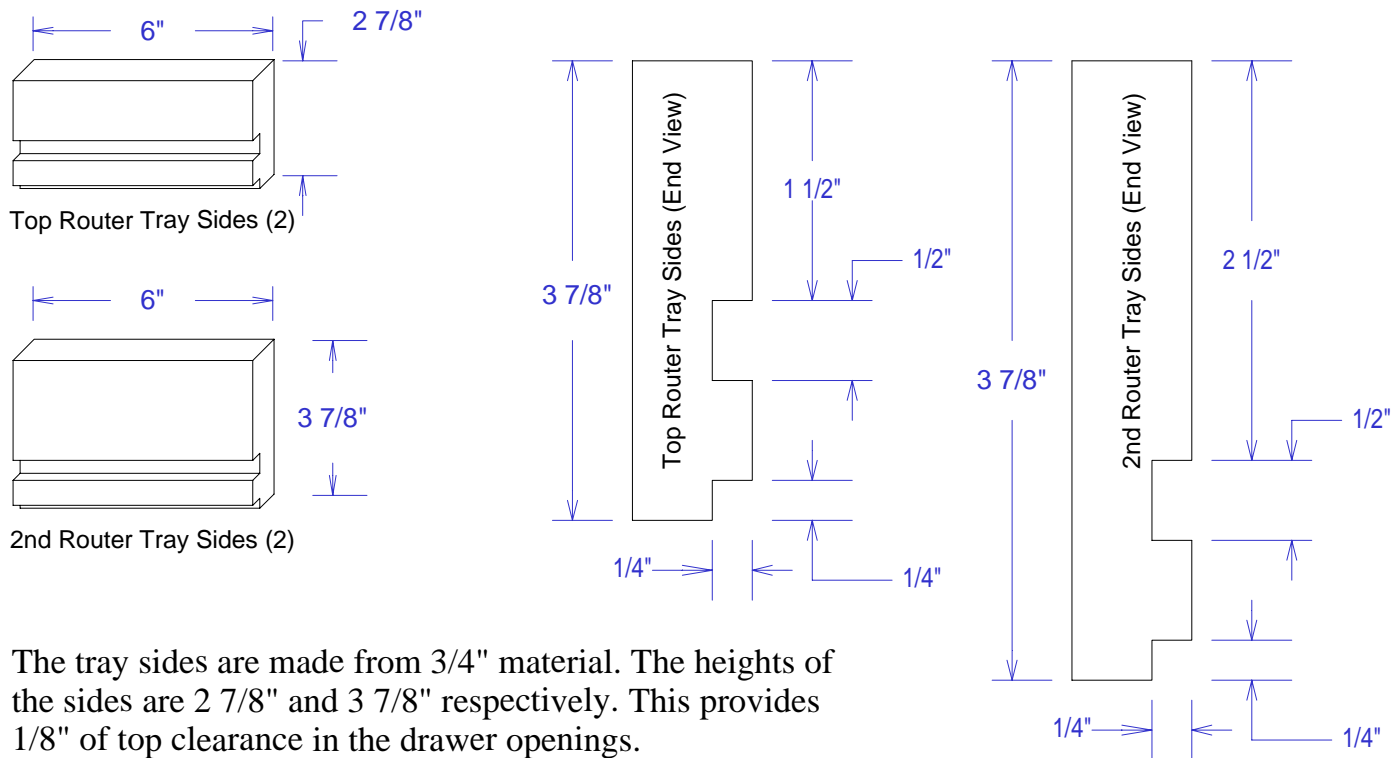

The tray sides are made from 3/4" material. The heights of the sides are 2 7/8" and 3 7/8" respectively. This provides 1/8" of top clearance in the drawer openings.

Cut 1/2" wide by 1/4" deep slots for the router trays in the sides as shown. Then cut a 1/4" rabbet on the bottom of each side as shown. The 1/4" rabbets are for the bottoms. The bottoms are necessary so the router bits cannot protude past the bottom of the drawer opening.

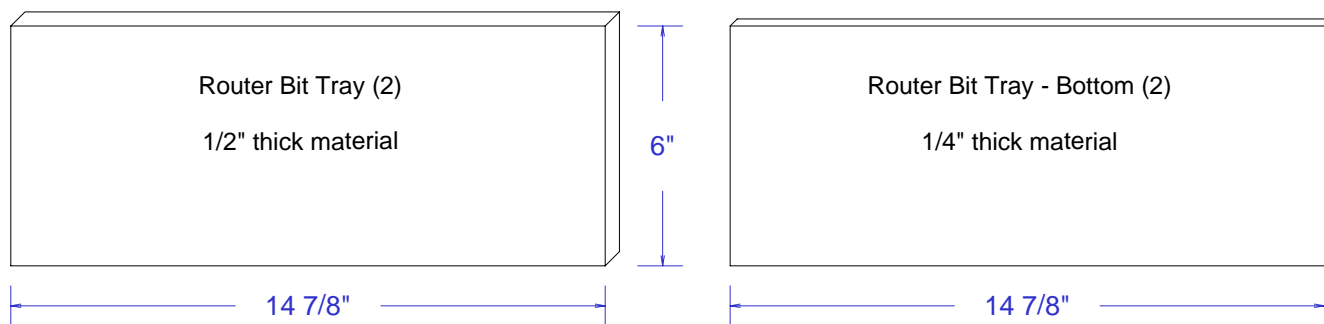

Cut two 6" by 14 7/8" router bits trays from 1/2" thick material and two bottoms from 1/4" thick material as shown above.

Drill several 1/4" and 1/2" holes for your router bits in the 1/2" thick sections. The exact location of the holes is strictly a matter of preference. I put the holes about 1 1/2" apart in the prototype.

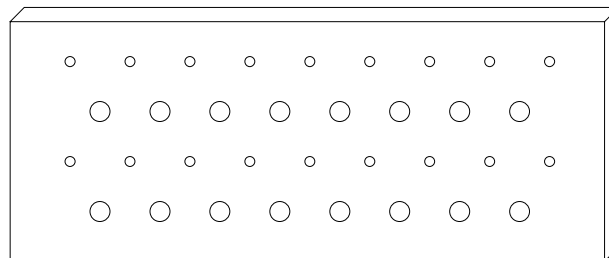

Middle Shelves Dimensions

Page 11

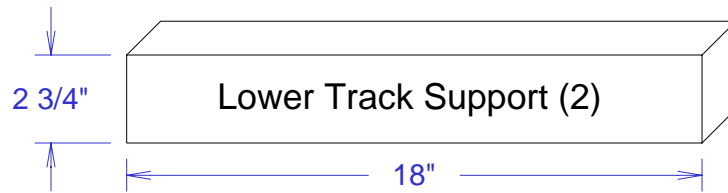
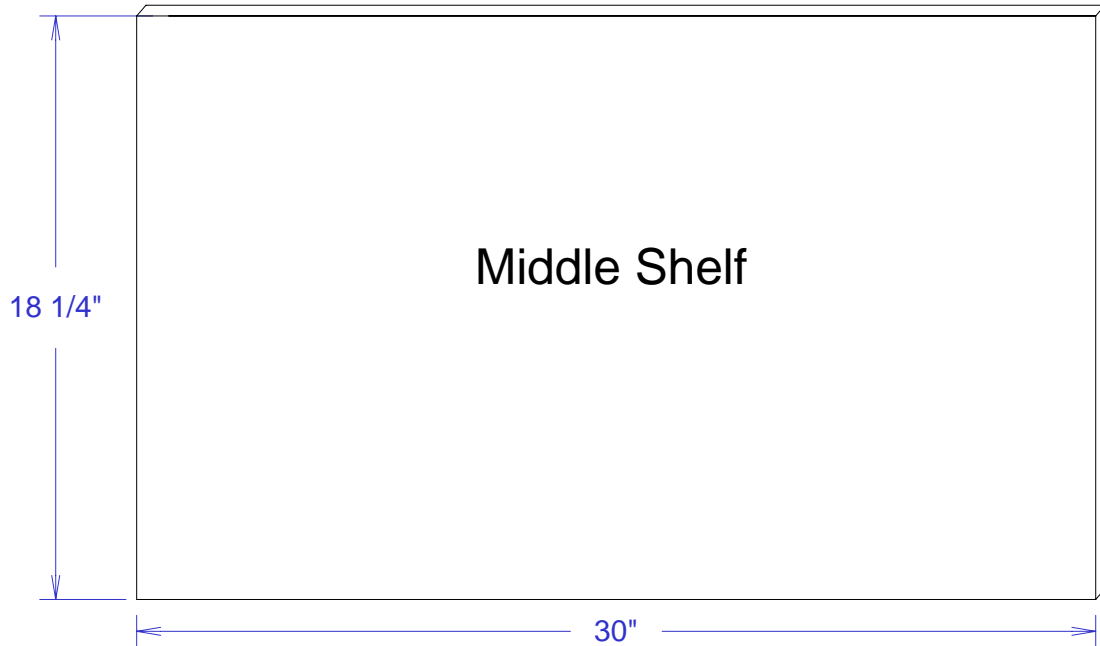

(Lower Track Support is made of $1 \frac{1}{2}"$ thick material.)

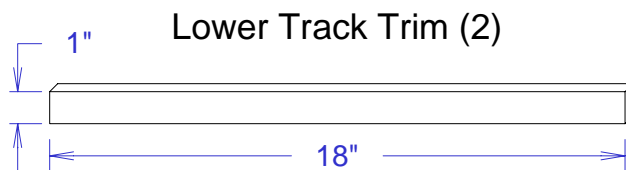

(Lower Track Trim is made of $\frac{1}{2}"$ thick material.)

Attach Drawer Slides Left Section - Left Panel

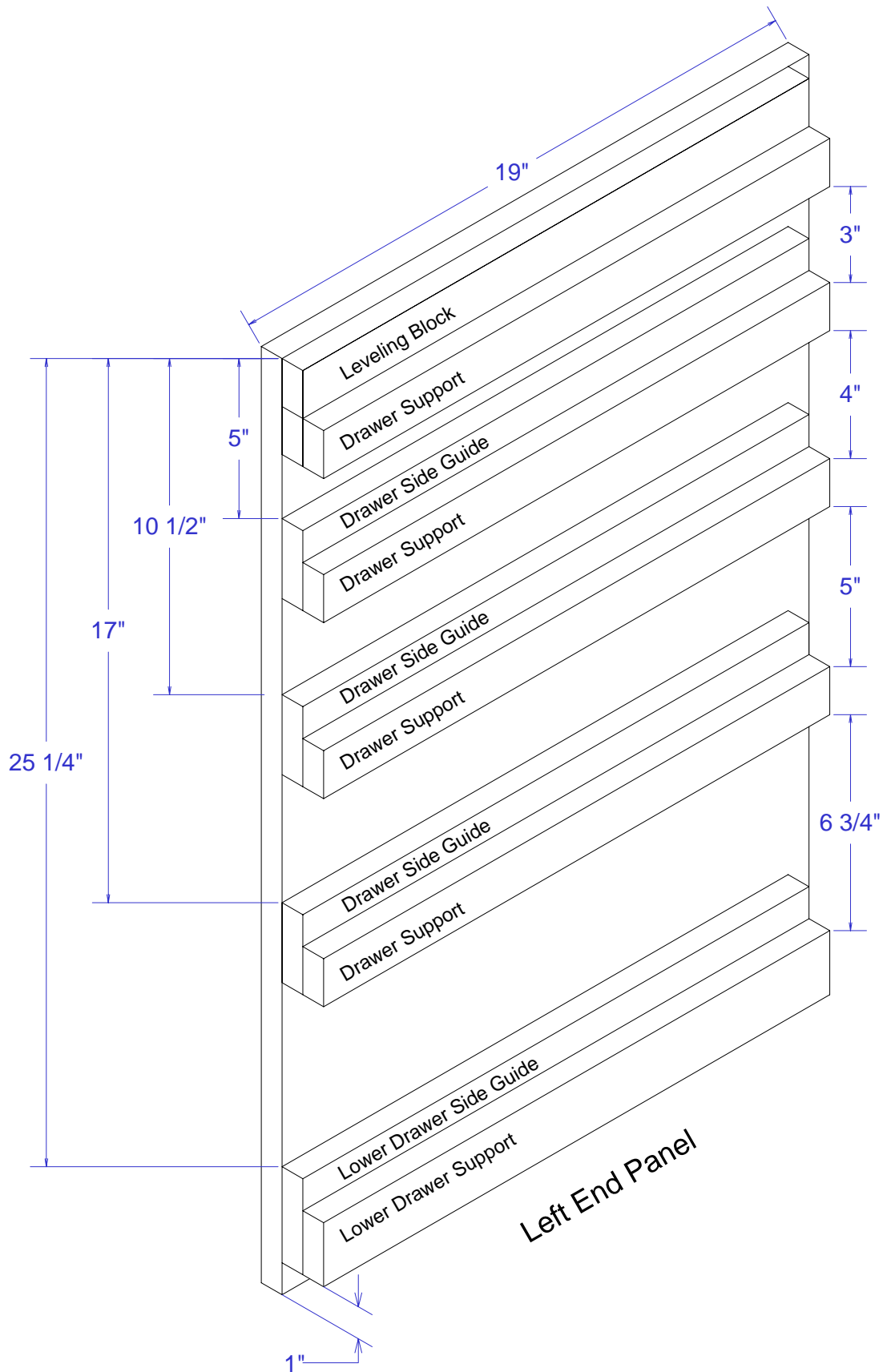

Attach Drawer Slides Left Section - Right Panel

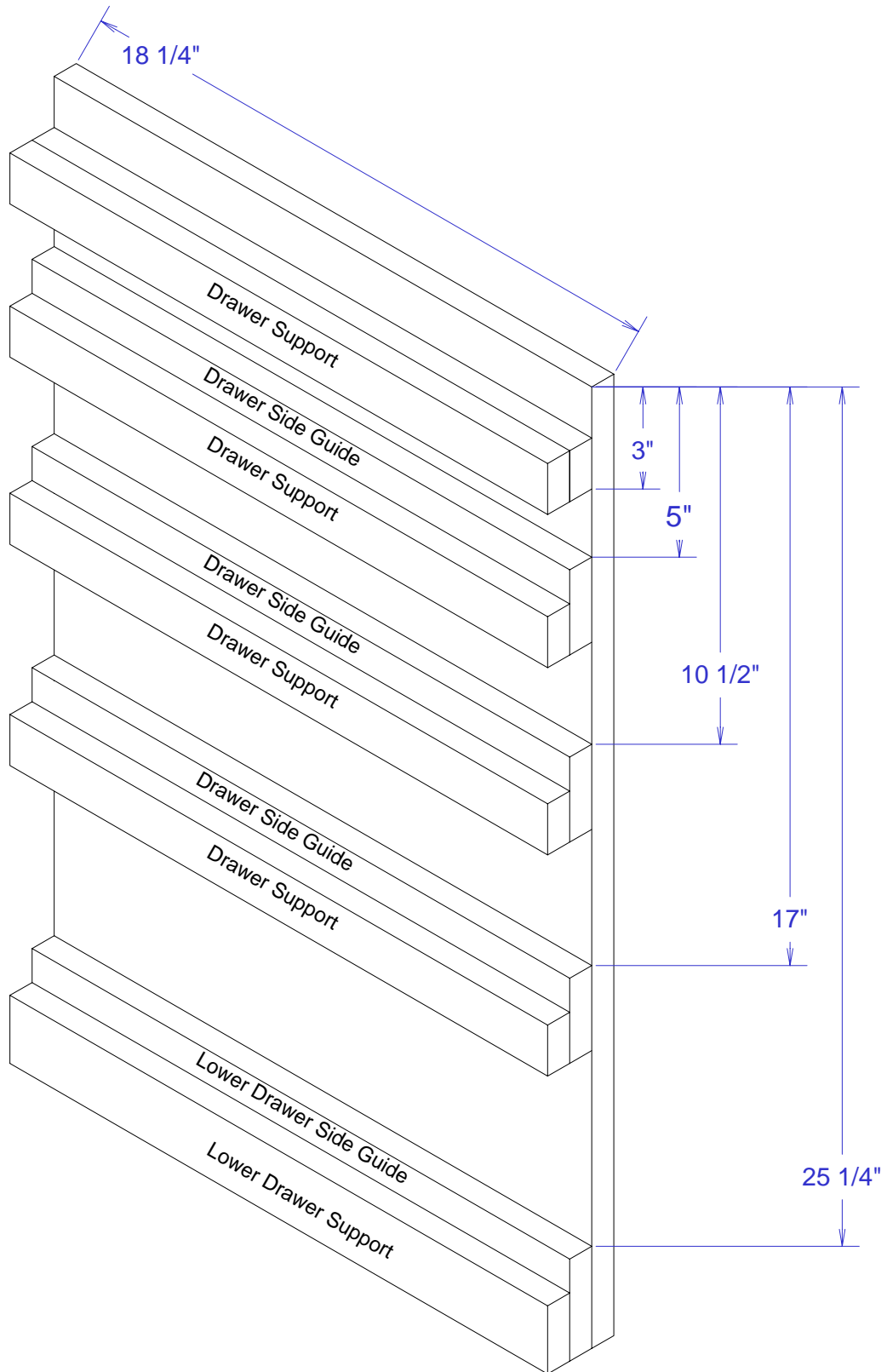

Attach Drawer Slides Center Section - Left Panel

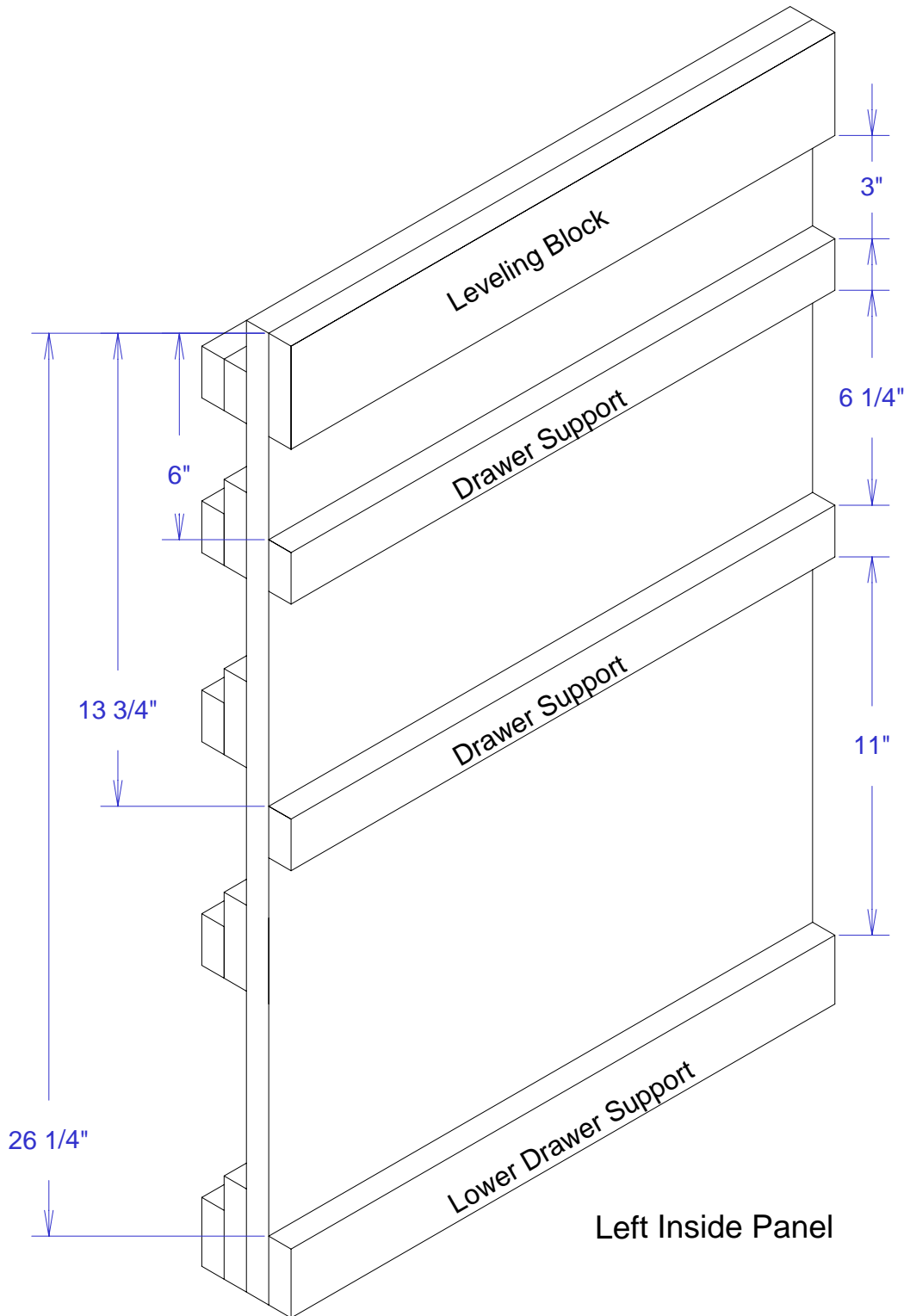

Attach Drawer Slides Center Section - Right Panel

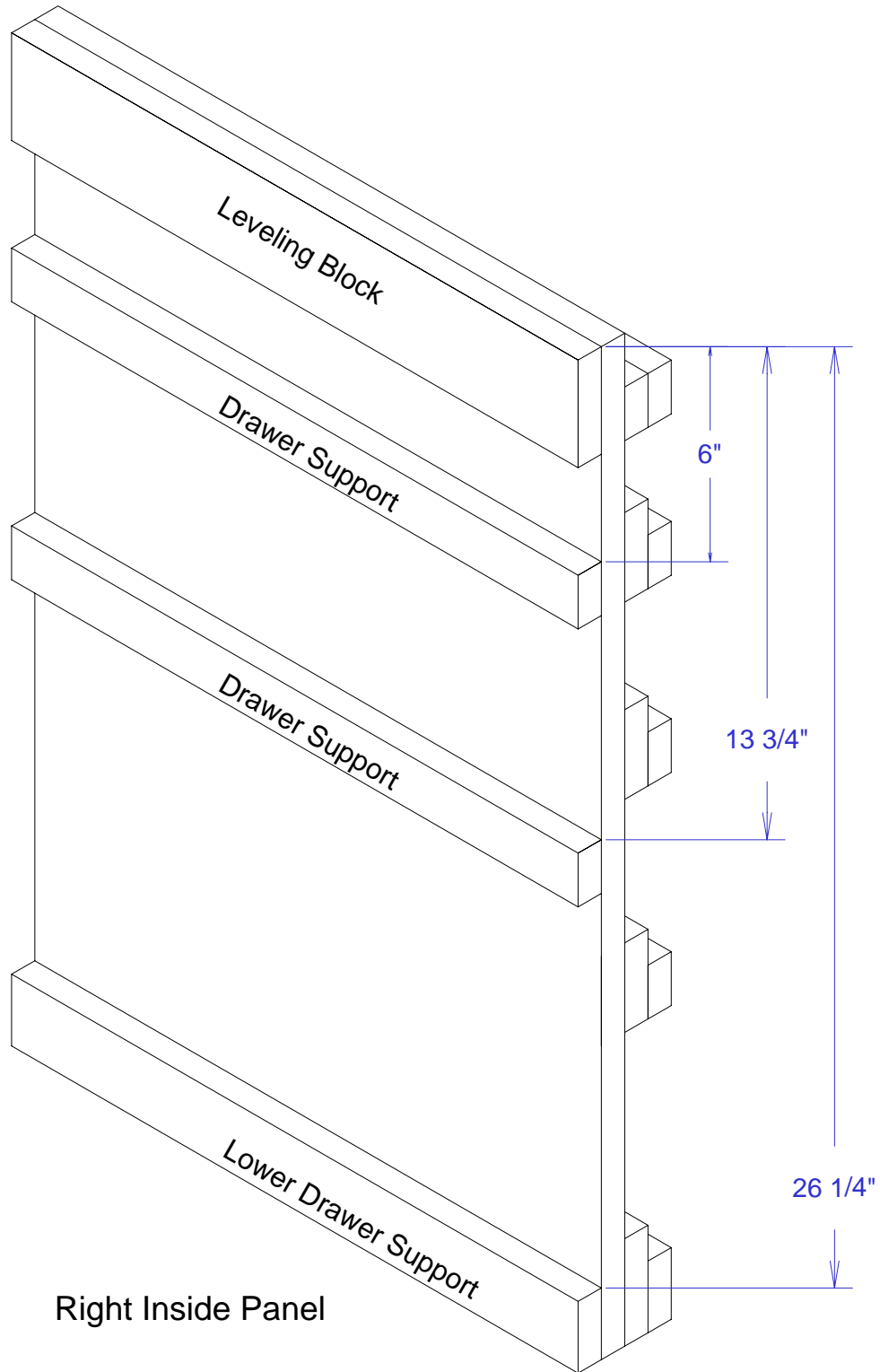

Attach Drawer Slides - Right Section - Left Panel

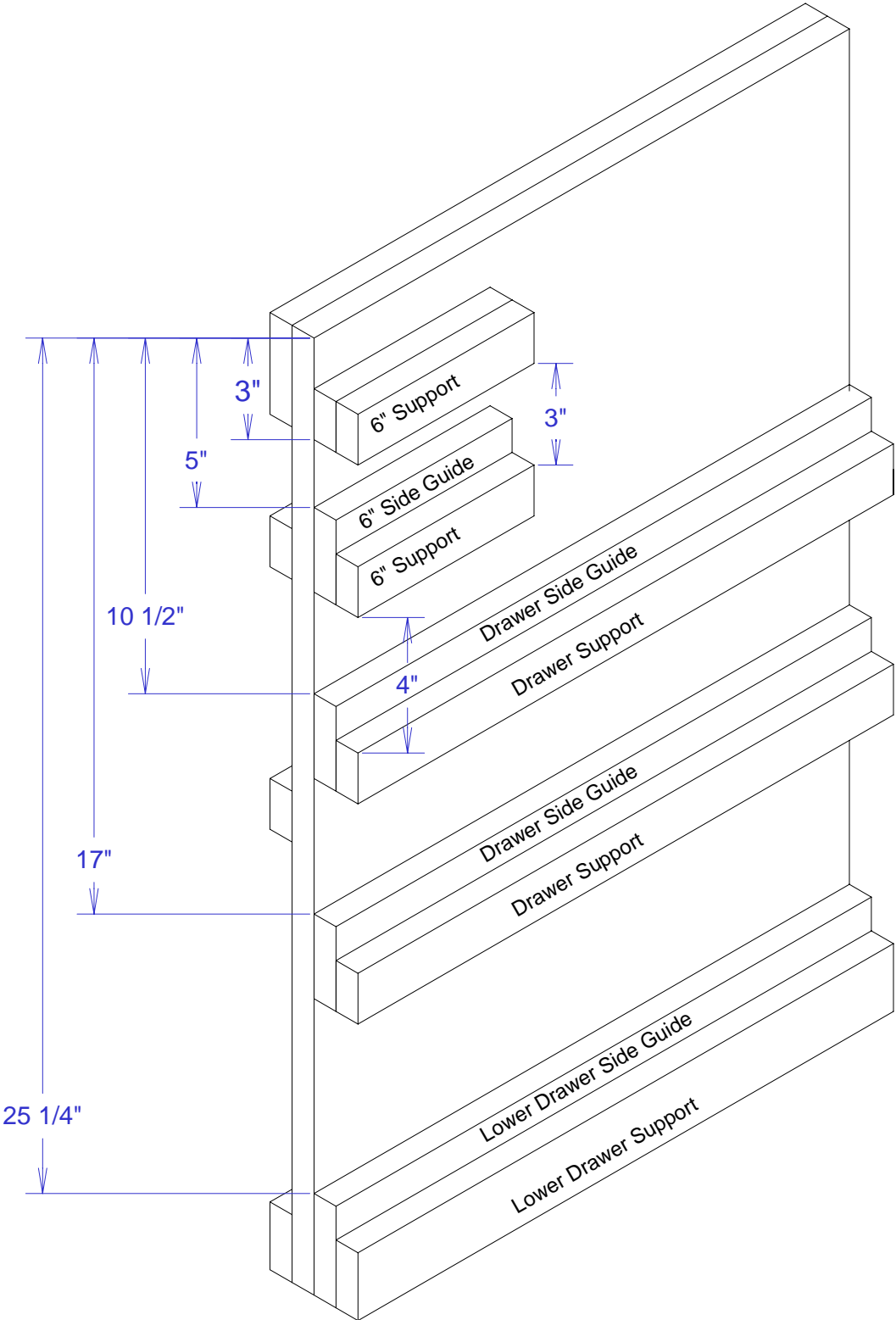

Attach Drawer Slides Right Section - Right Panel

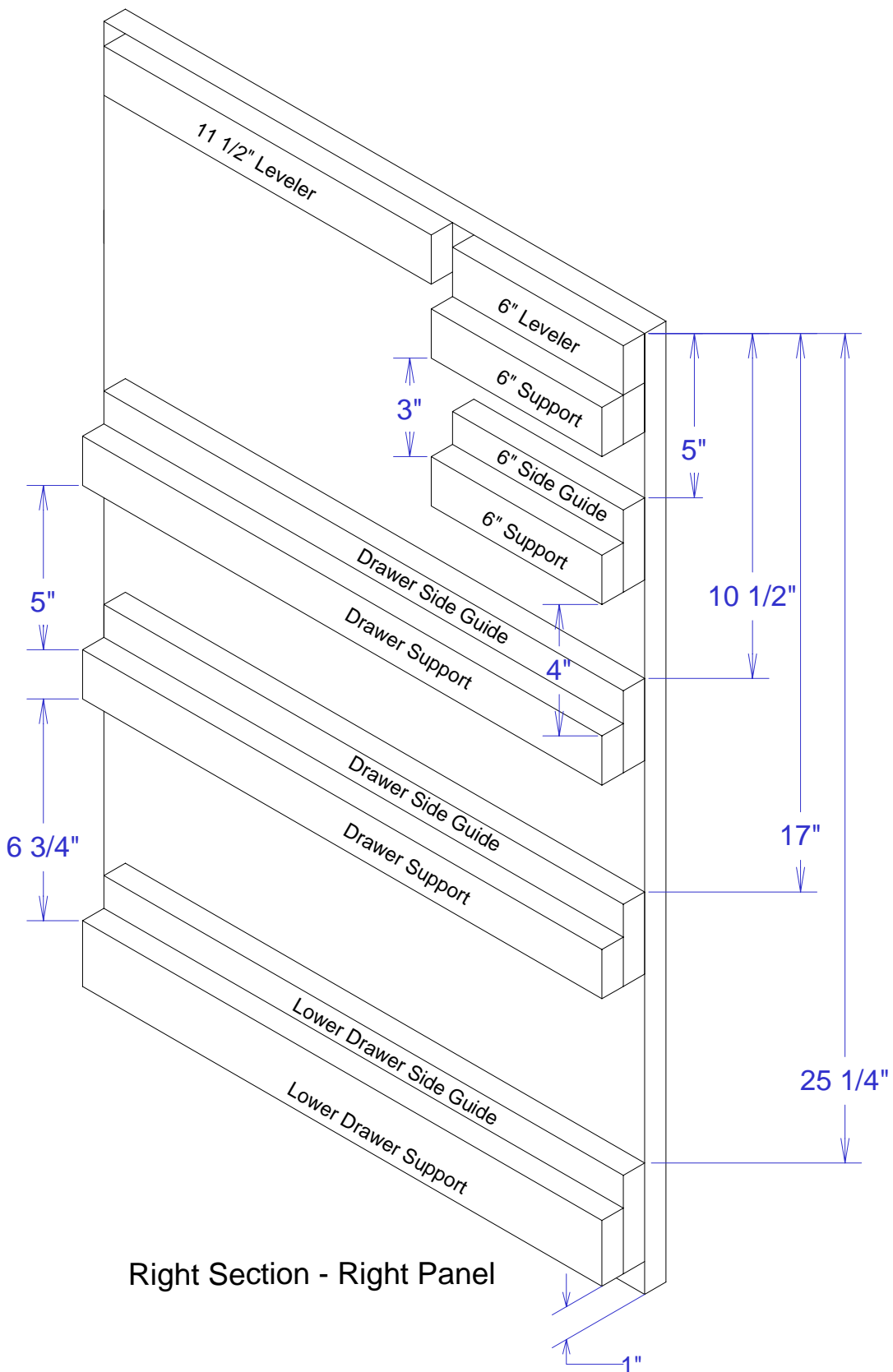

Attach the Panels to the Base

Page 18

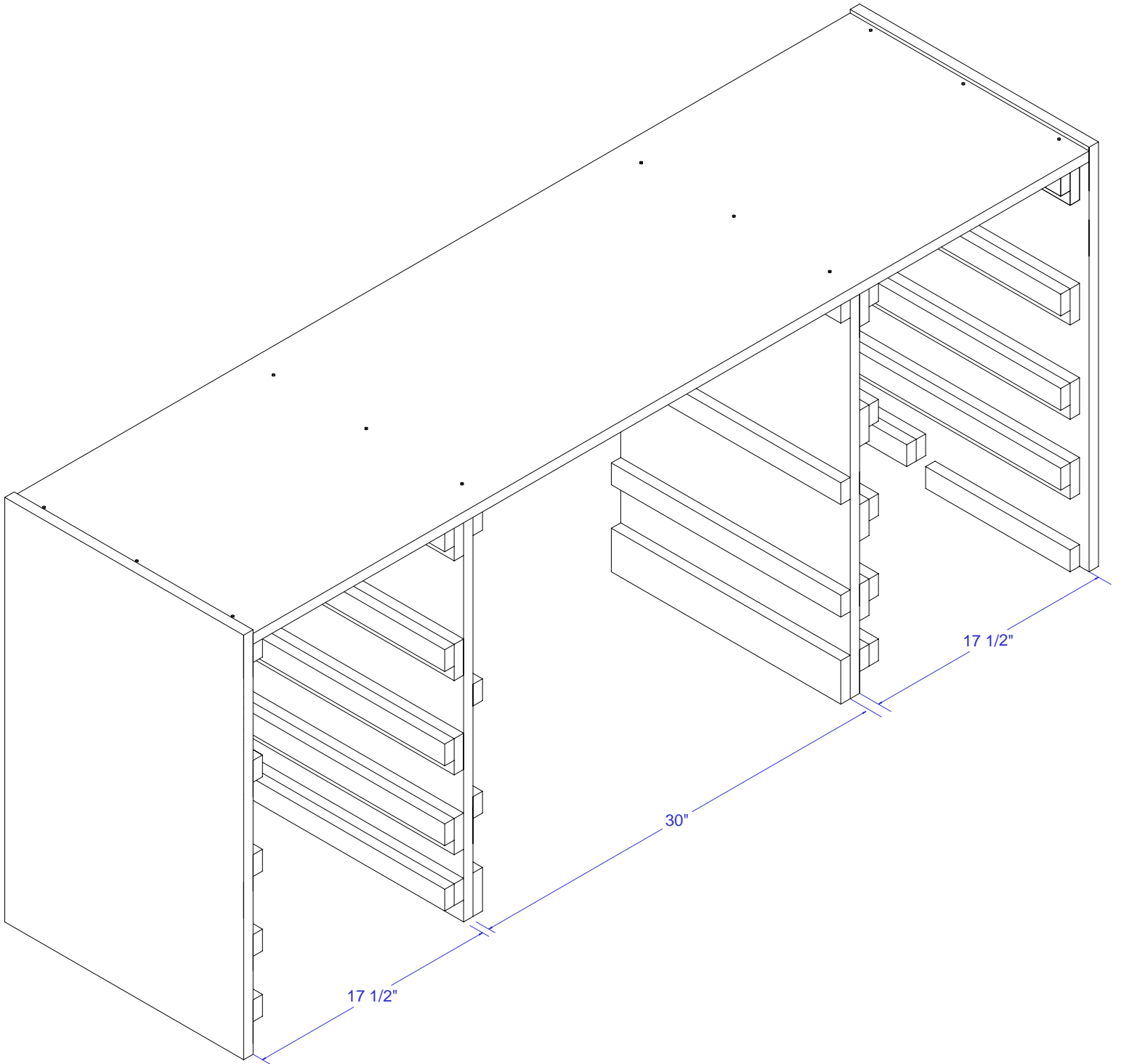

Attach the Stiffener & Casters to the Base

Page 19

Attach the casters to the base as shown. Then position the stiffener as close to the front as possible while still allowing clearance for the swivel casters to rotate. Mark the position of the stiffener, then drill about six holes for #8 wood screws through the base. Apply some glue and secure the stiffener to the base with 2" #8 screws.

The screw heads will be inside cabinet below the drawers so it doesn't matter if you use flathead or pan head screws..

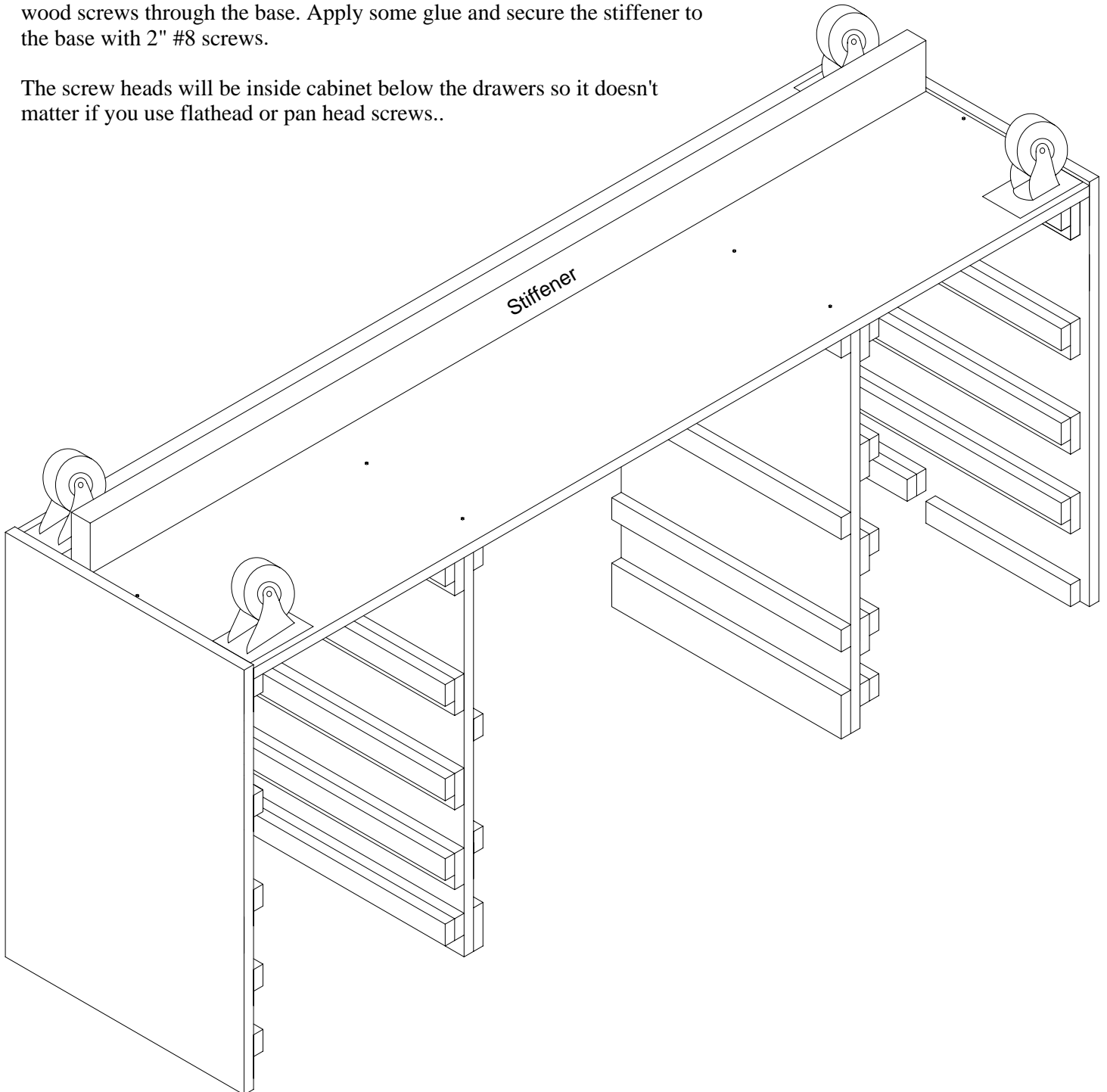

Attach The Back

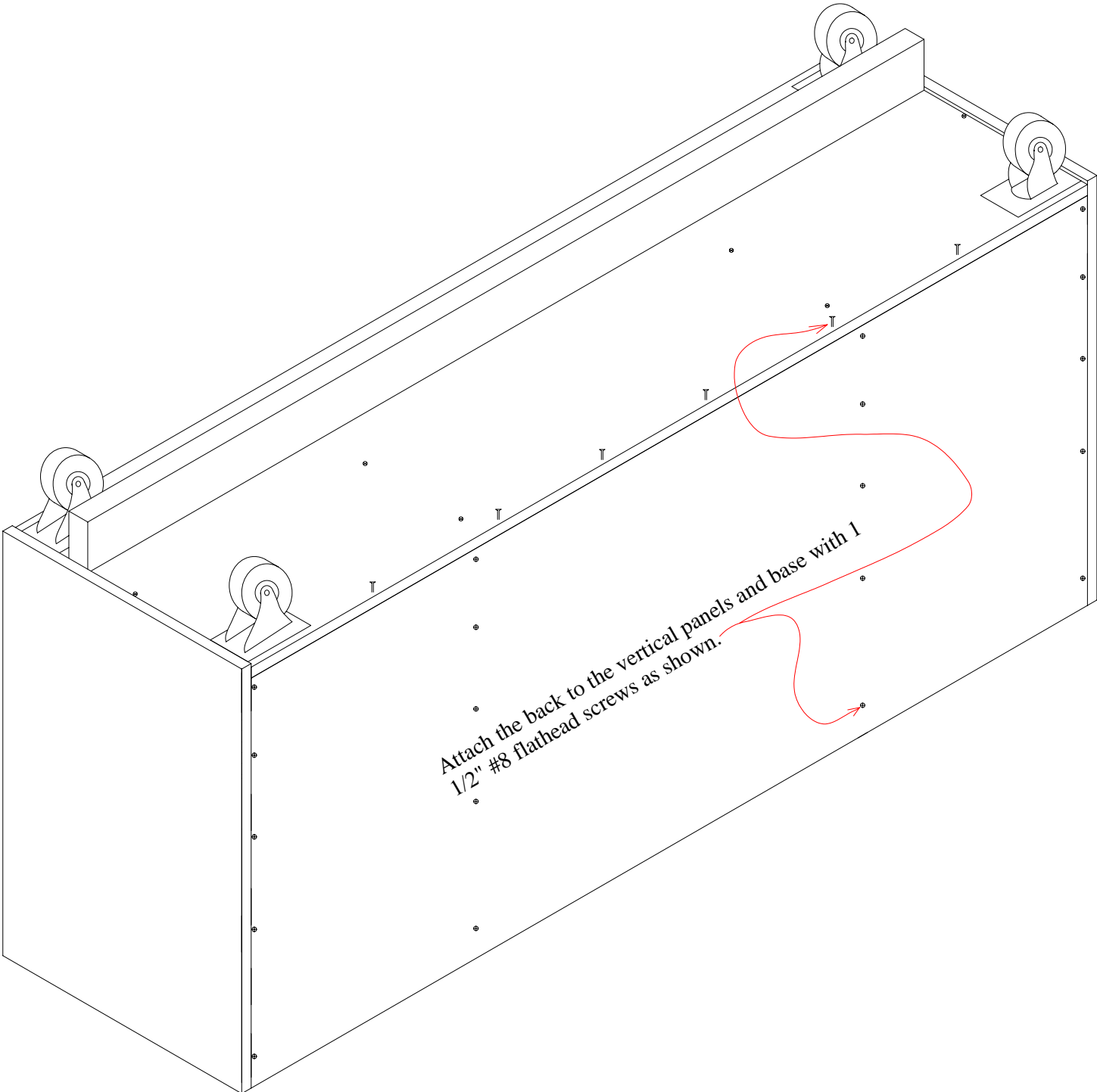

Attach the Router Box Bottom & Middle Shelf

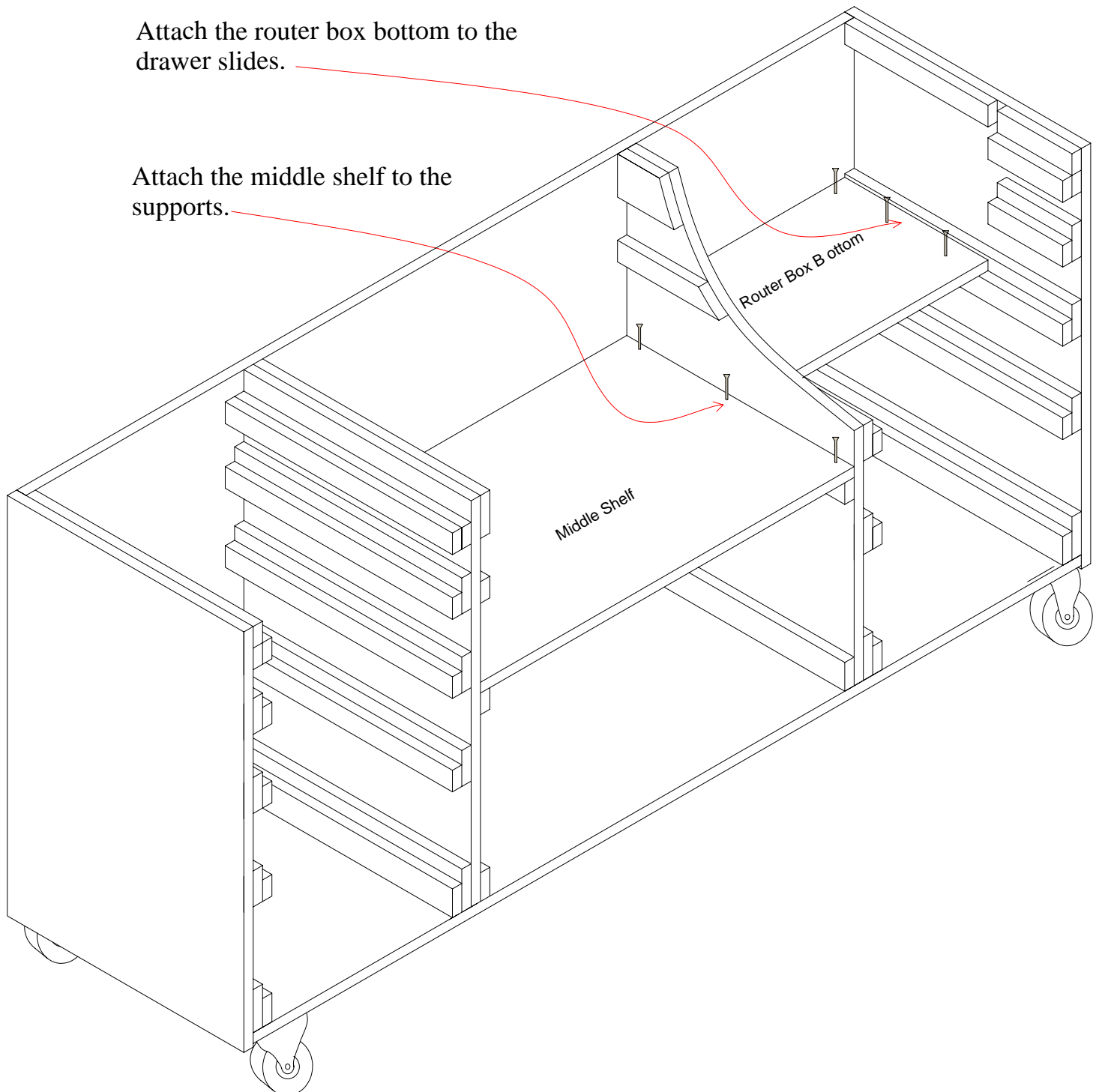

Attach the Router Box Front

Page 22

Attach the router box front to the router box bottom and to the rear end surface of the drawer slides.

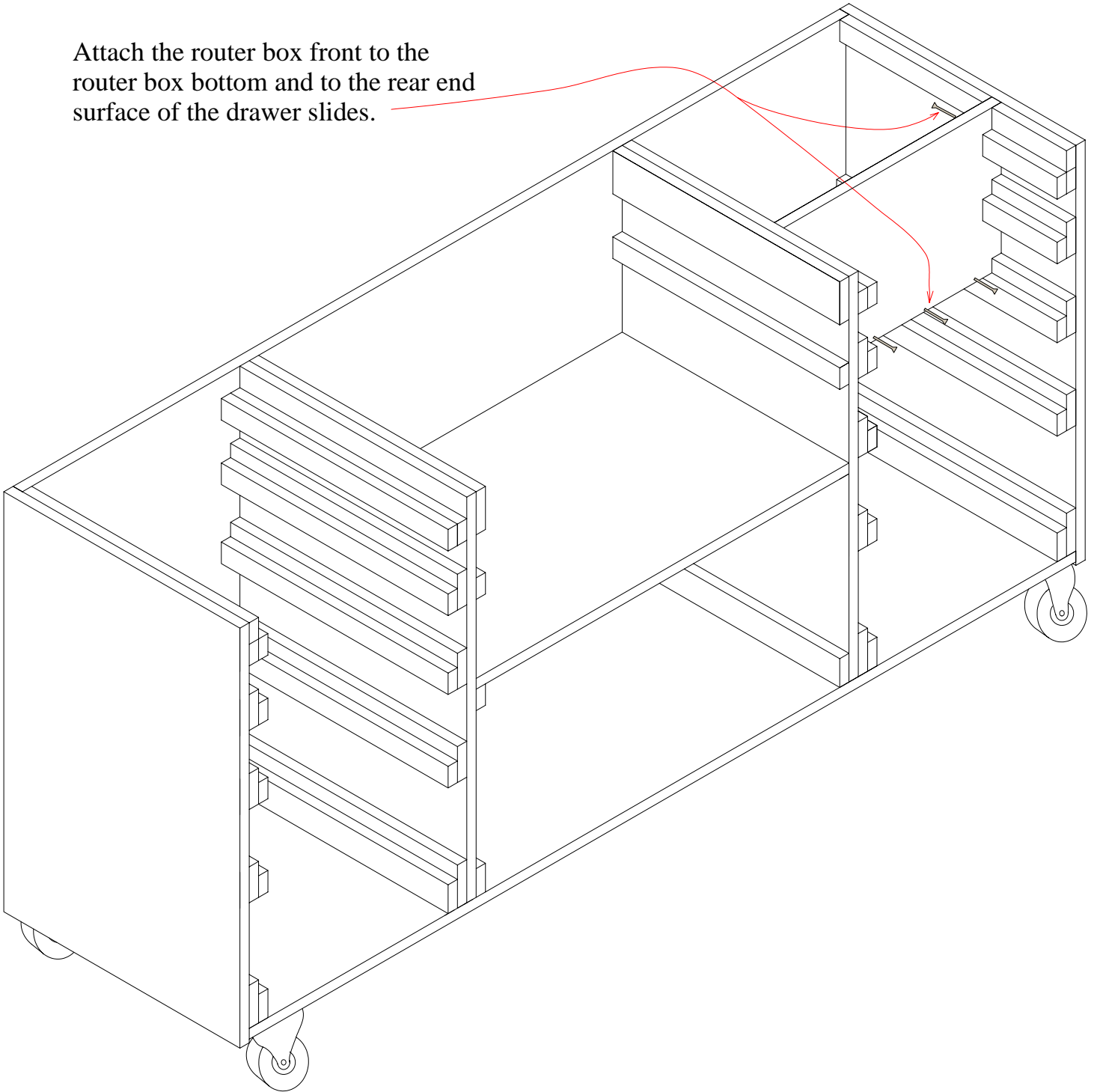

Assemble the Face Frame

Page 23

Don't forget! The pocket holes go on the back side of the face frame.

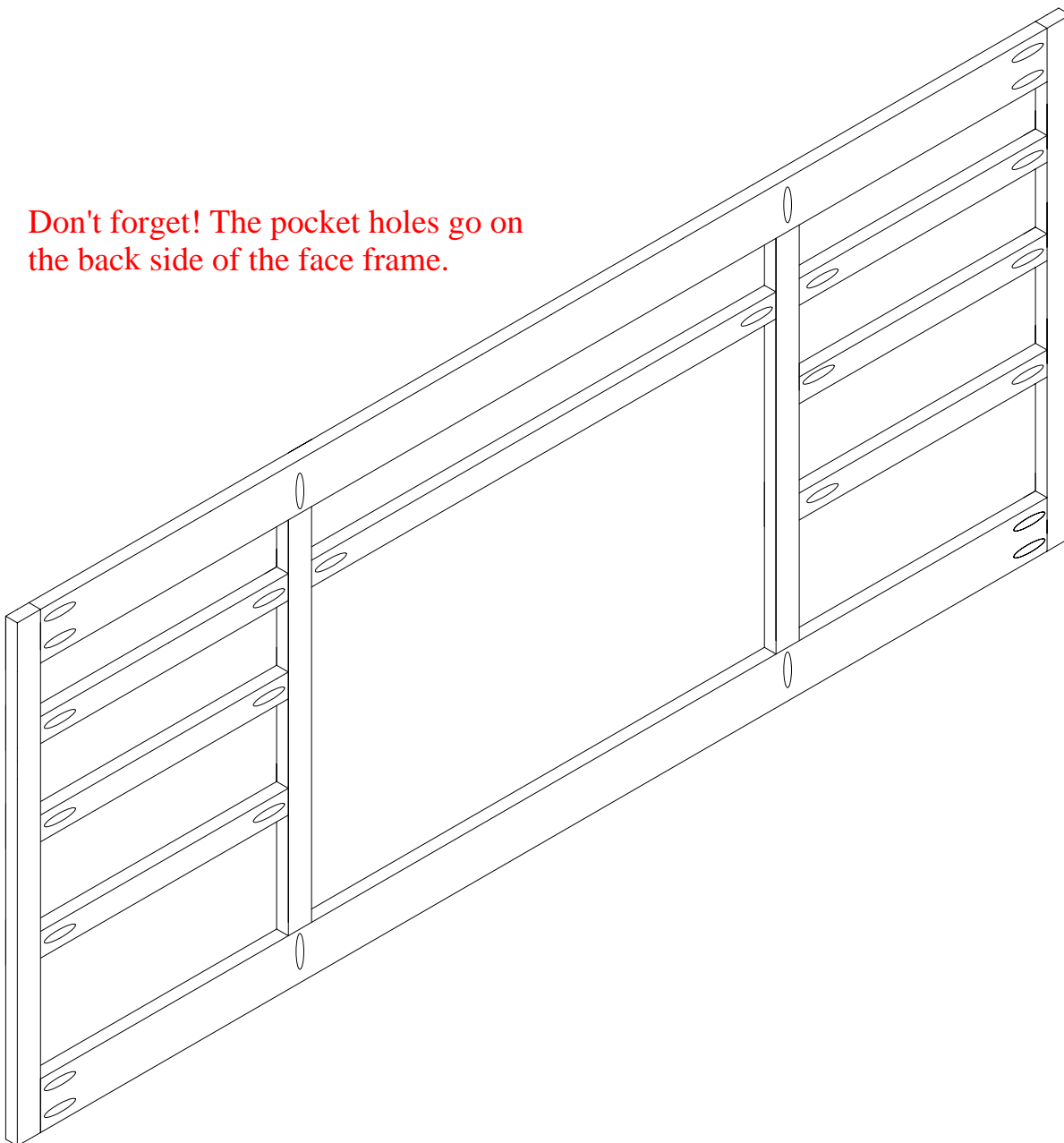

Assemble the front trim pieces (face frame) as shown. Be sure the horizontal drawer separator pieces are properly spaced so they line up with the drawer slides.

The top of each piece of horizontal drawer separator trim should be flush with the top of a drawer slide.

Pocket holes are the easiest way to join trim or face frames as they are often called. if you don't have a pocket hole jig, you can use dowel joints.

Attach the FaceFrame to the Cabinet

Page 24



Attach the assembled face frame to the cabinet with finishing nails. Then, countersink and fill the nail holes with wood putty.

Attach the Leveling Blocks to the End and Center Panels

Page 25

Now, you are ready to attach the leveling blocks. This is the way you ensure that the top is perfectly flat when the workbench is completed. First, drill three 1/4" diameter holes completely through each leveling block, (the two shortest ones only need two holes). The exact location of the holes is not critical. Drill a hole about 2" from each end and one in the middle of each leveling block. To keep the glue from setting before you're finished, it's best to attach the end and center panel leveling blocks first and ensure they are level with each other before attaching the front and rear ones.

Apply some glue to the mating faces and attach the end and center panel leveling blocks using 1 1/2" #8 pan head screws with flat washers as shown. Do not tighten the screws yet as the blocks must be leveled first.

After all the blocks are in place, use a straight edge to ensure the top surfaces of all the leveling blocks are level with each other. If you have a four foot level, that would work great.

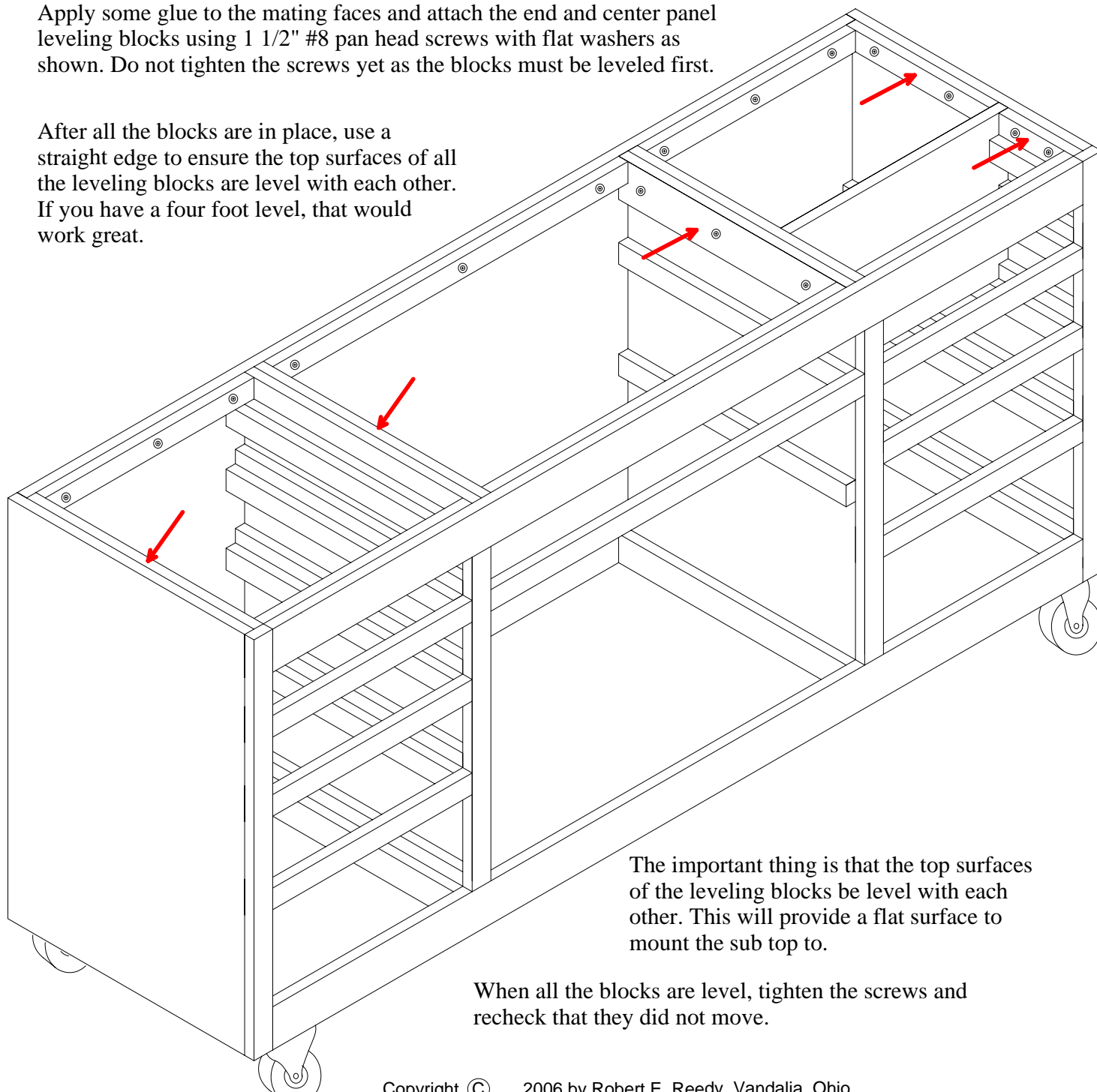

The important thing is that the top surfaces of the leveling blocks be level with each other. This will provide a flat surface to mount the sub top to.

When all the blocks are level, tighten the screws and recheck that they did not move.

Attach the Front & Rear Leveling Blocks

Page 26

Apply glue to the mating surfaces and attach the front and rear leveling blocks as shown in the diagram. Use your straight edge to ensure the tops are even with the tops of the end and center leveling blocks. Then tighten the screws.

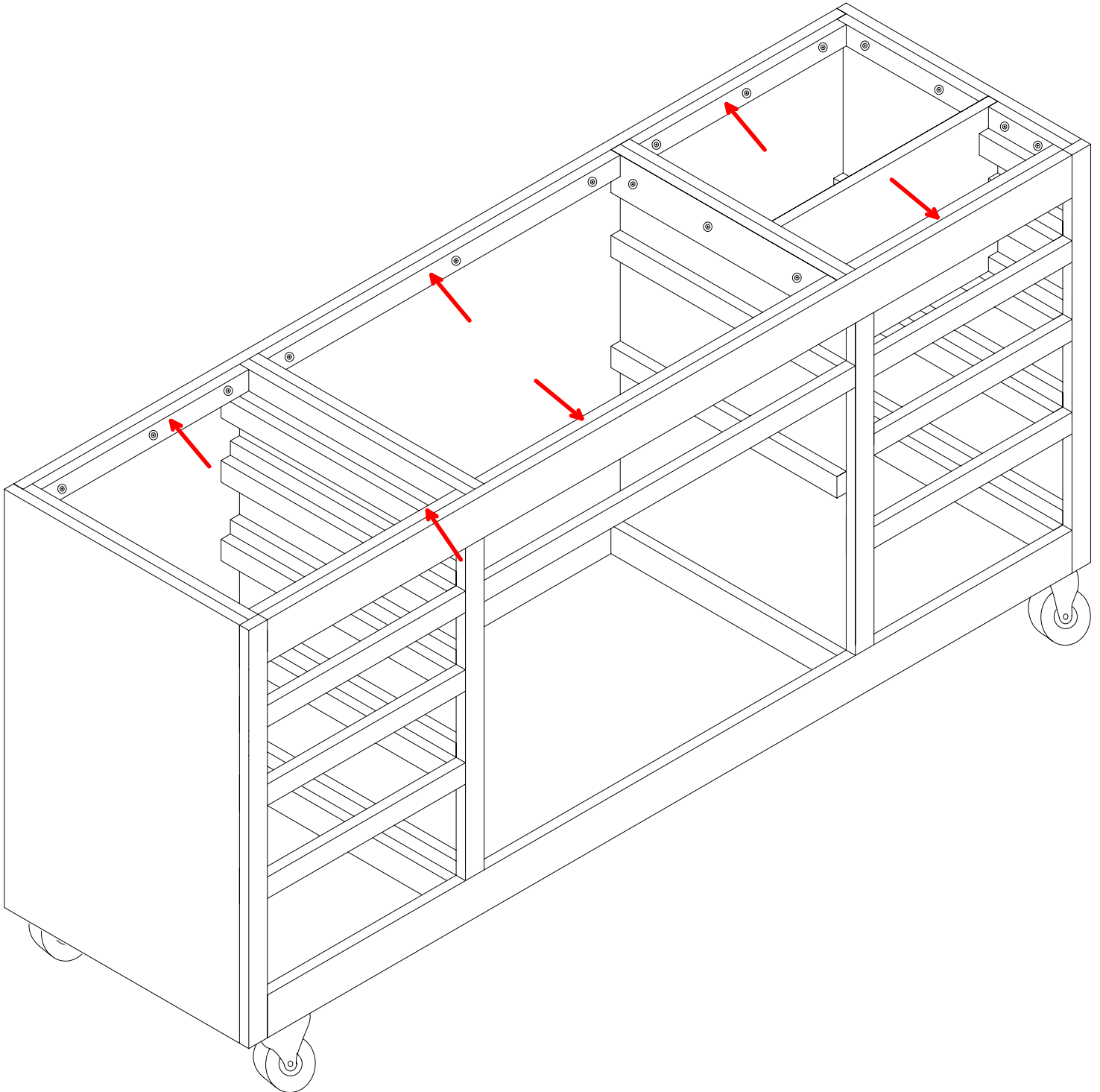

Attach the Sub Top to the Cabinet

Page 27

Attach the Sub Top with 1 1/2" #8 flathead screws. The Sub Top should be flush to the edges of the cabinet on all four sides.

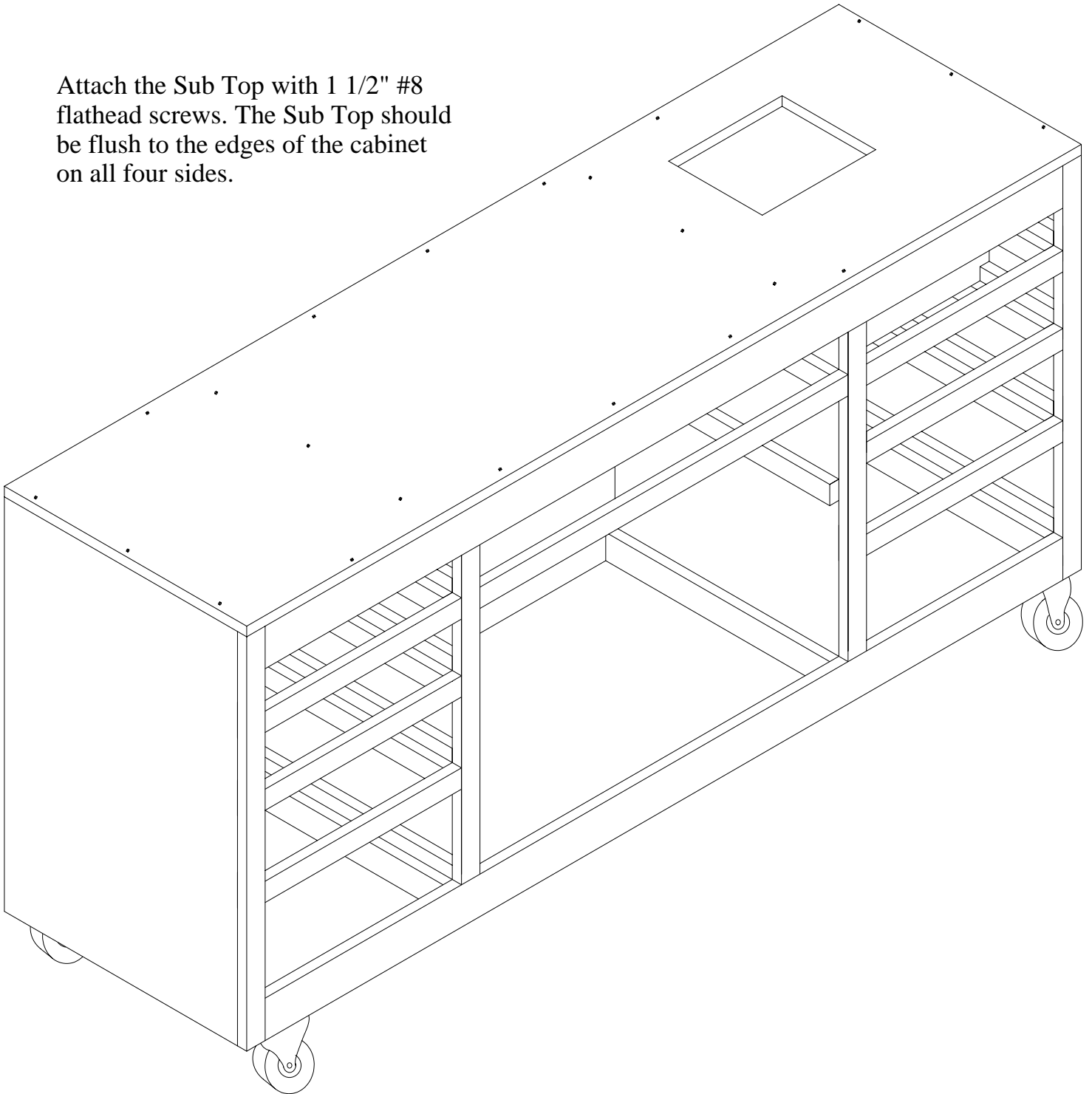

Attach the Inner Sub Top Trim

Page 28

Attach the Inner Sub Top Trim to the Sub Top with 1 1/2" #8 flathead screws. Be sure the top of the trim is flush with the top surface of the Sub Top.

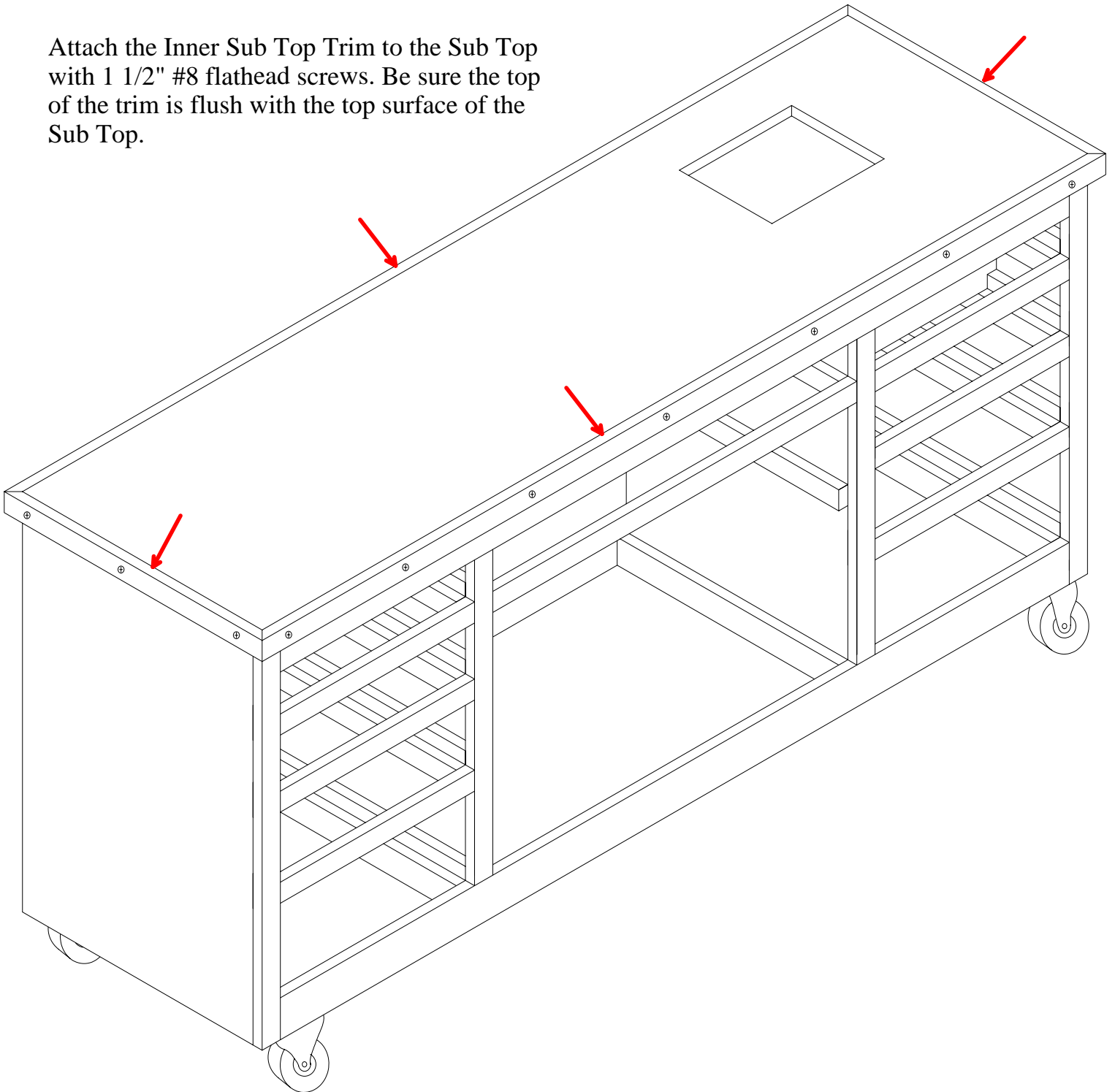

Attach the Middle Trim to the Inner Sub Top Trim

Page 29

Attach the Middle Sub Top Trim to the Inner Sub Top Trim with 1 1/2" #8 flathead screws. Be sure to space these screws so they don't interfere with the screws in the inner trim or the T-Track which will be attached to the Middle Sub Top trim. The pocket holes will be used to attach the edges of the top to the trim.

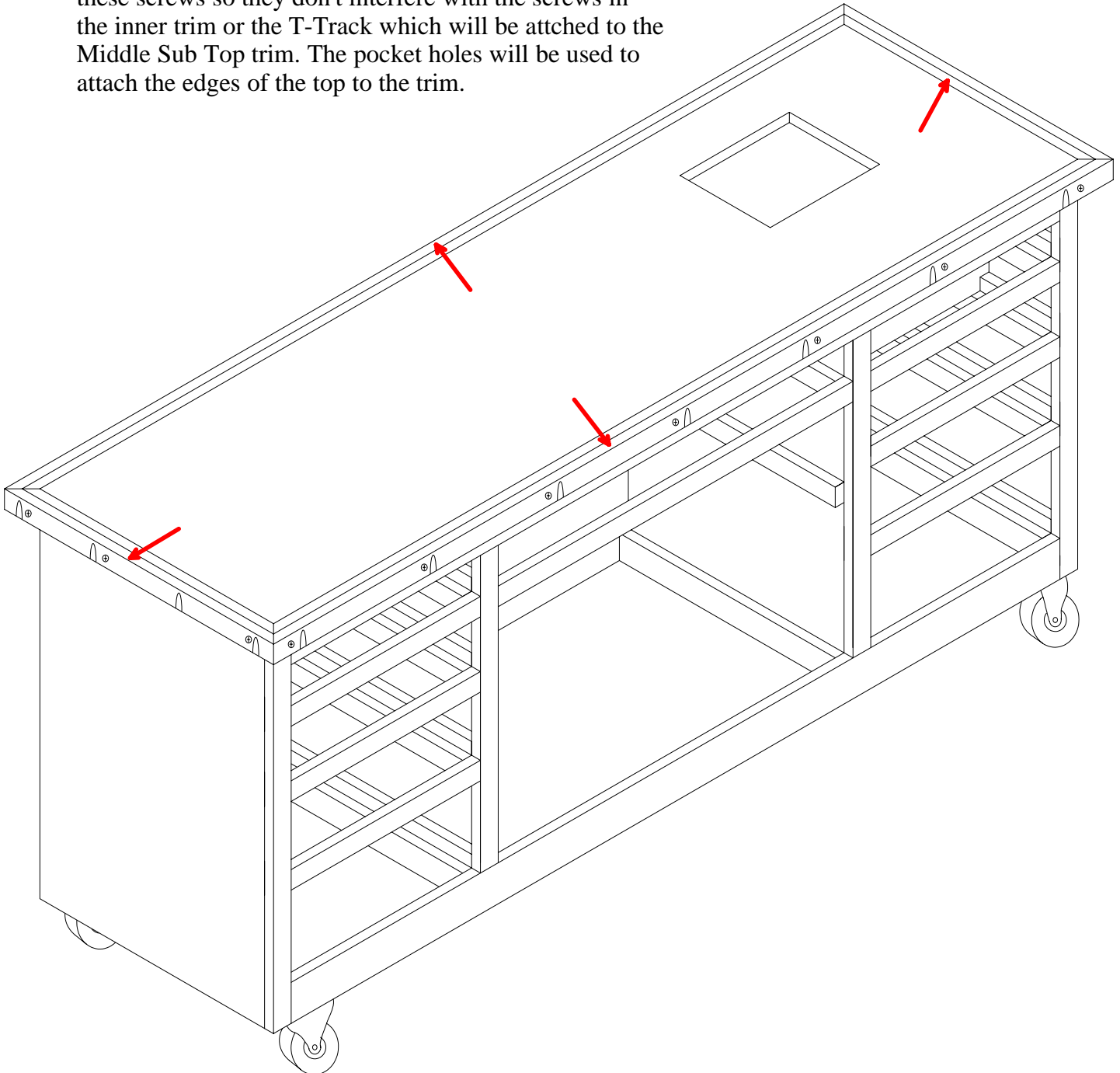

Attach the Top to the Sub Top

Page 30

Attach the Top to the Sub Top with 1" #8 flathead screws through the cutouts for the T-Track and Miter gauge track. Secure the edges of the top with pocket hole screws through the holes you drilled through the Inner Sub Top Trim. If you don't have a pocket hole jig, you can glue the Top to the Sub Top. However, gluing it will make it much more difficult to replace the top in the future if you need to.

Note: The dimensions given in these plans are based using T-Track that is 3/4" wide and 1/2" thick. If your T-Track is a different size, you will need to modify the thickness of the inner trim accordingly.

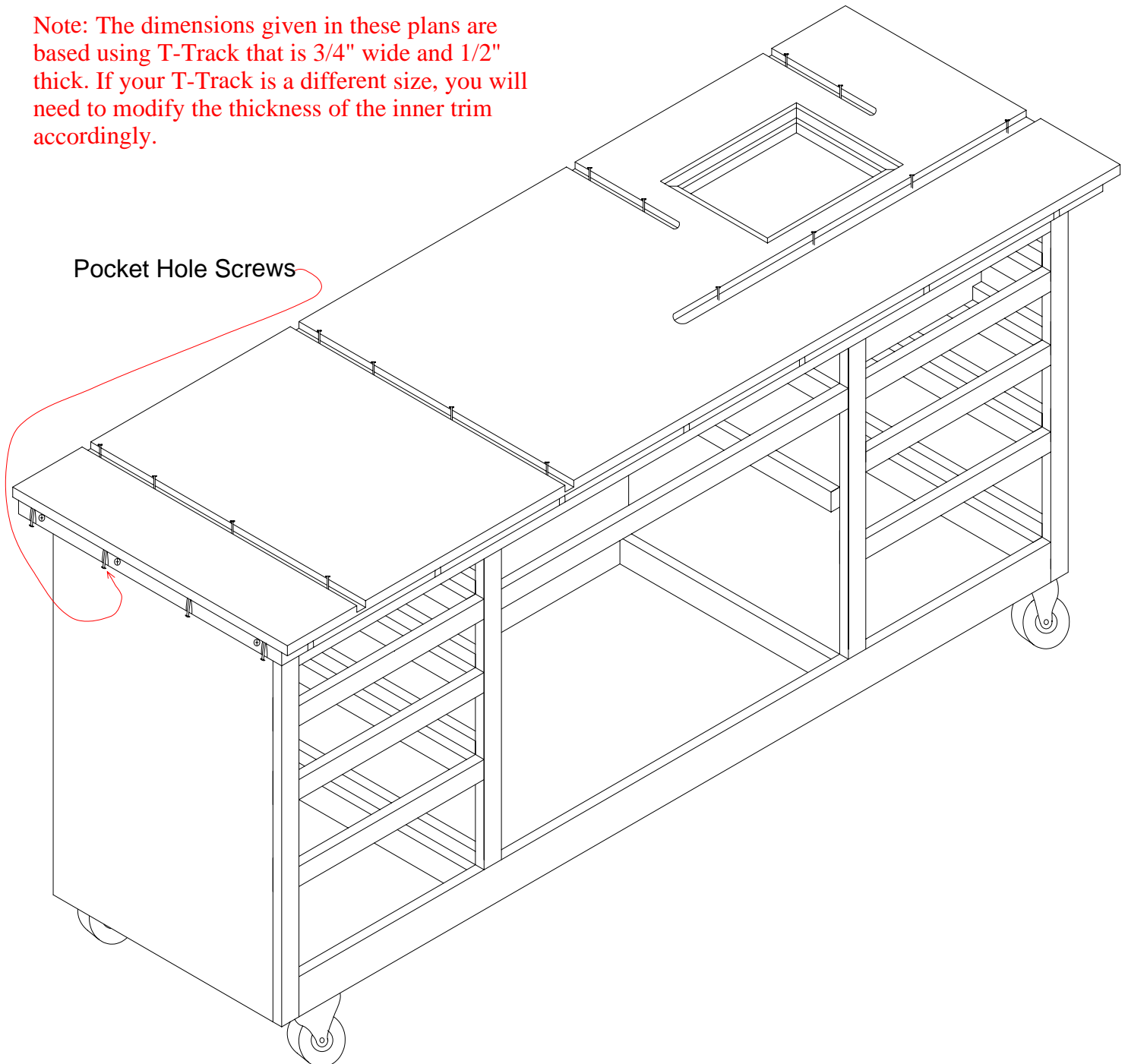

Attach the T-Track & Miter track to the Top

Page 31

Attach the T-Track to the top as shown with 1" #6 screws. Some manufacturers countersink the holes for mounting the track and others do not. From my experience, I prefer flathead screws with countersunk holes. This keeps the screw heads from interfering with the bolts sliding through the track. The track I used for the prototype was designed for pan head screws, so I countersunk them on my drill press.

The miter guage track is not subject to much stress so you can glue it in the slot. If you use screws, be sure the screw heads are below the surface so the miter guage does not hang up on them. I would not recommend polyurethane glues because they expand as they set up. The expanding glue would lift the miter track up above the surface of the workbench top. A construction adhesive like liquid nails works fine.

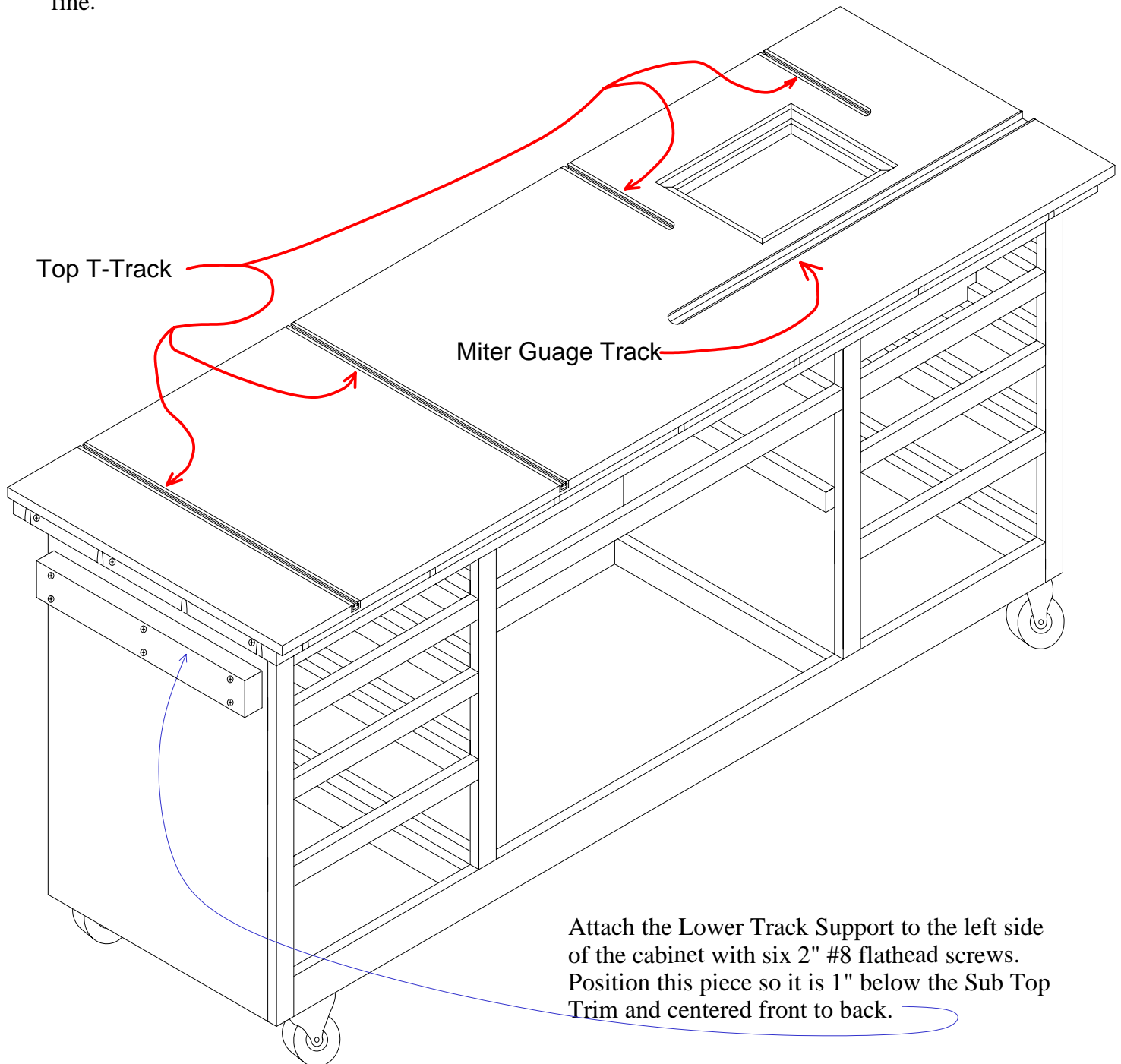

Attach the Lower Track Support to the left side of the cabinet with six 2" #8 flathead screws. Position this piece so it is 1" below the Sub Top Trim and centered front to back.

Attach the T-Track to the Edges of the Front and Ends

Attach the edge T-Track on each end and along the front to the middle Sub Top Trim with 1" #6 screws. Position this T-Track under the bottom surface of the Top as shown in the detail drawing.

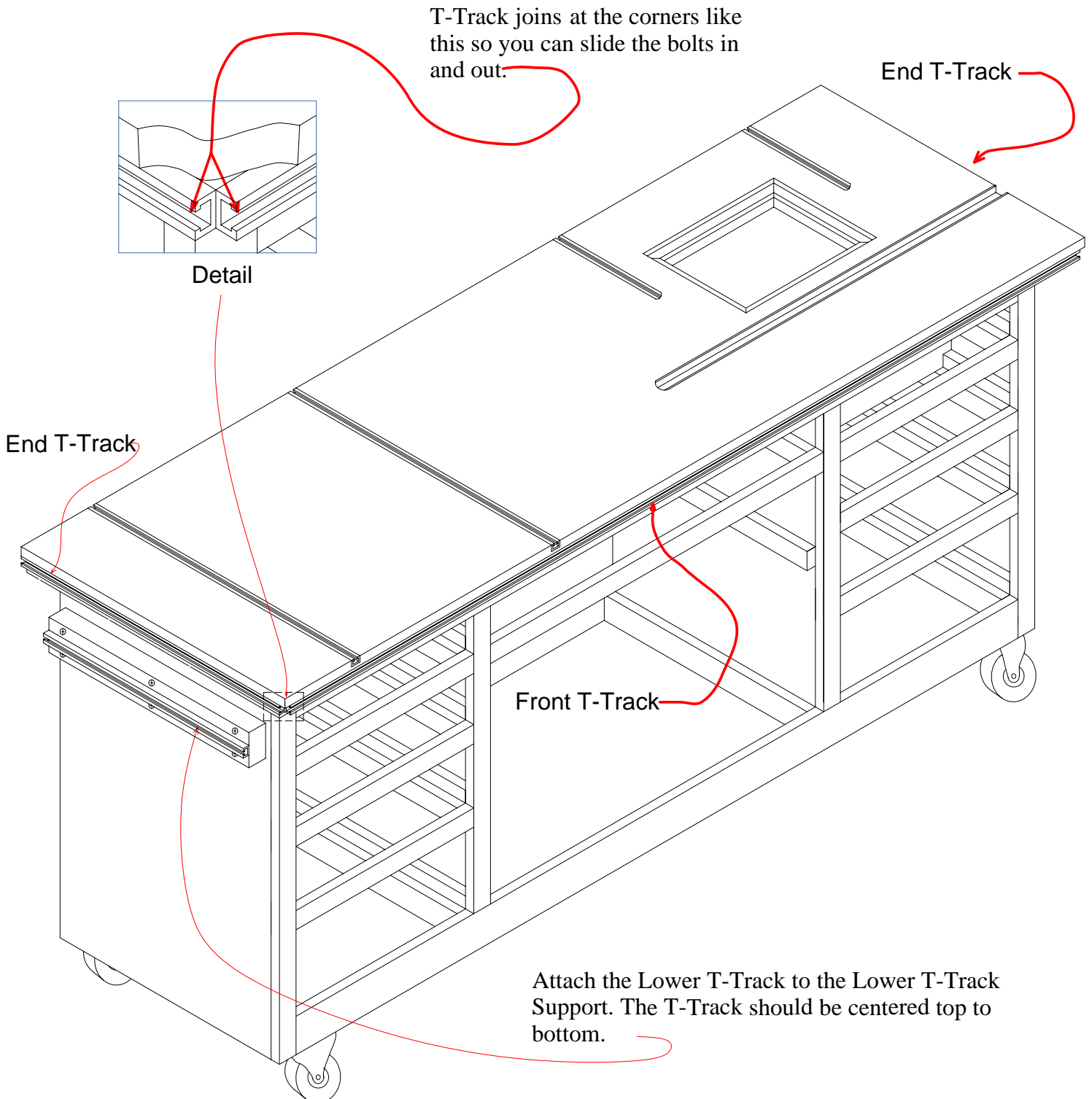

Attach the Lower Front Trim to the Front and Ends

Attach the Lower Top Trim on each end and along the front to the middle Sub Top Trim with 1 1/2" finishing nails.

If you cut the top a little larger than the dimensions called for, you can trim it with your router and a flush trimming bit. Use the Lower Top Trim for the bit bearing to follow.

The Lower Top Trim joins at the corners like this.

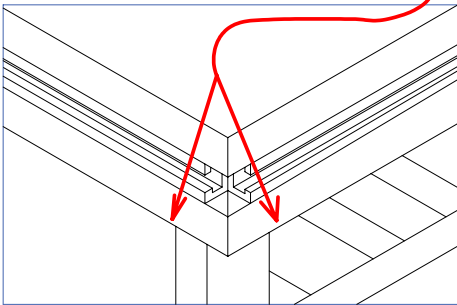

Detail

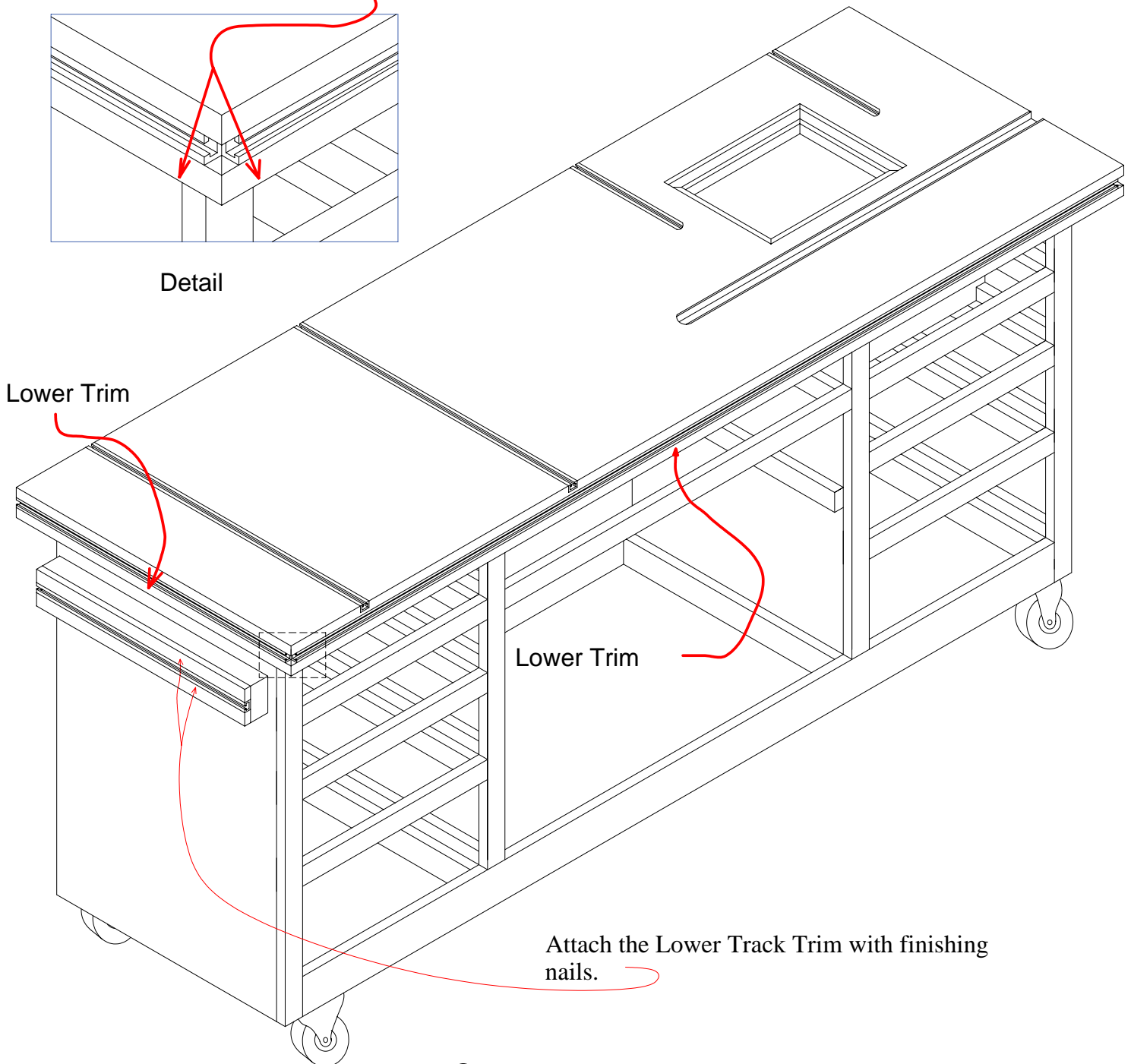

Attach the Lower Track Trim with finishing nails.

Assemble the Drawers

Page 34

Apply a little glue to the mating surfaces and assemble the drawer boxes.

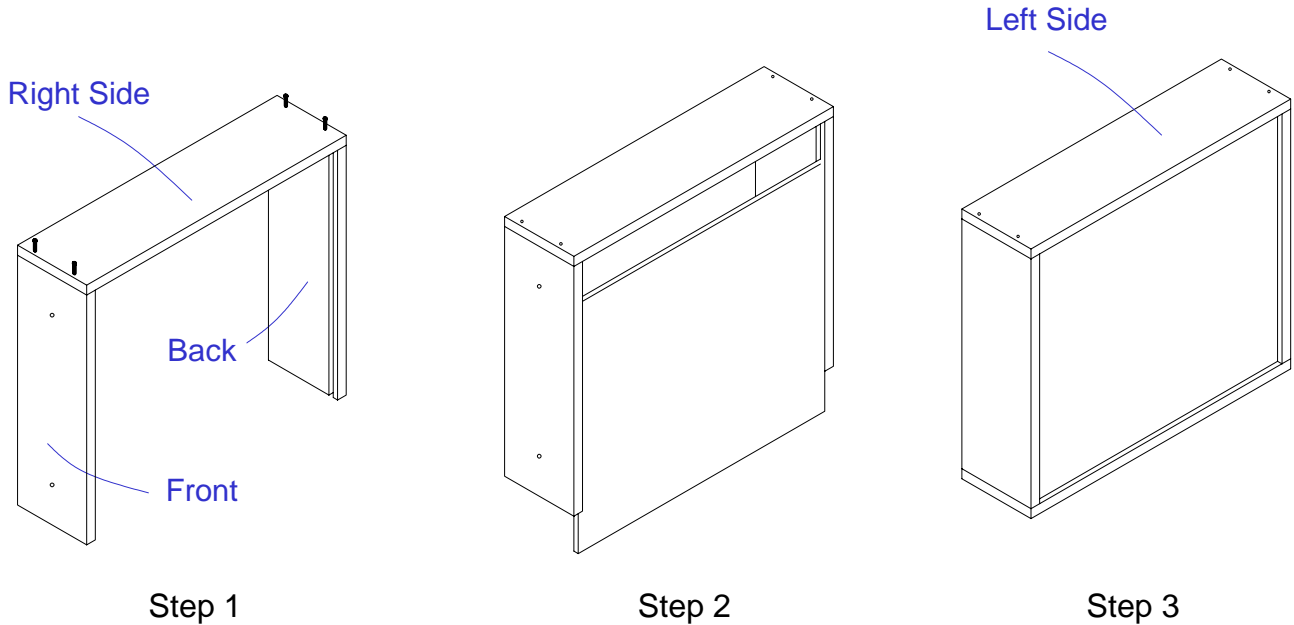

Assemble the front, back, and right side with finishing nails as shown in Step 1. Insert the bottom as shown in Step 2. Attach the left side as shown in Step 3.

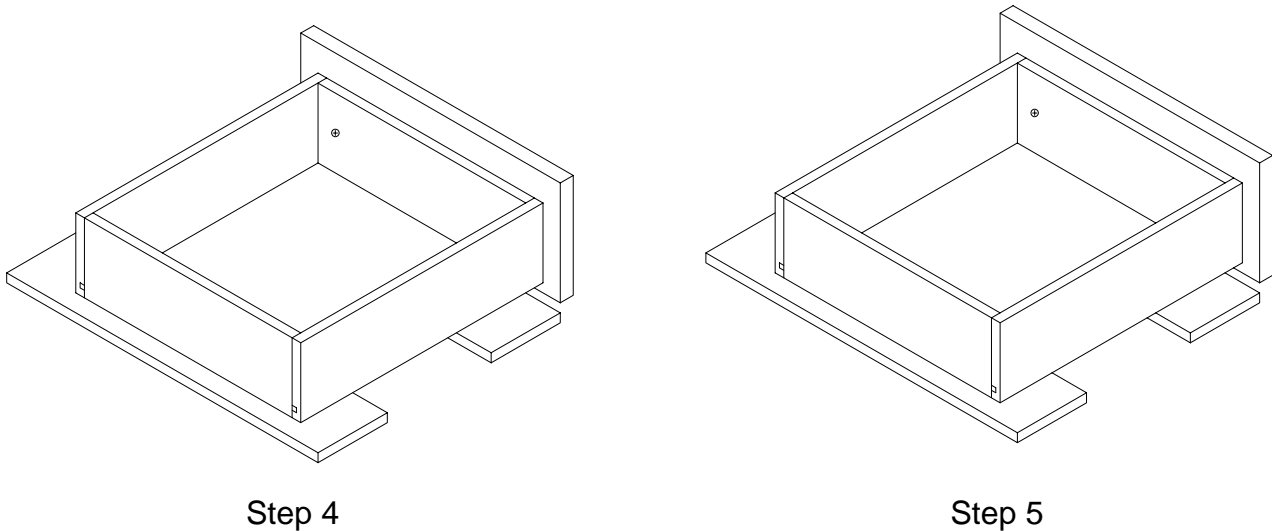

Support the drawer boxes with 1/4" thick strips of wood and attach the drawer fronts with 1 1/8" screws as shown. This is necessary because the bottom of the front must be 1/4" below the bottom of the box so it will overlap the rear cabinet trim when installed.

Assemble the Router Bit Trays

Page 34

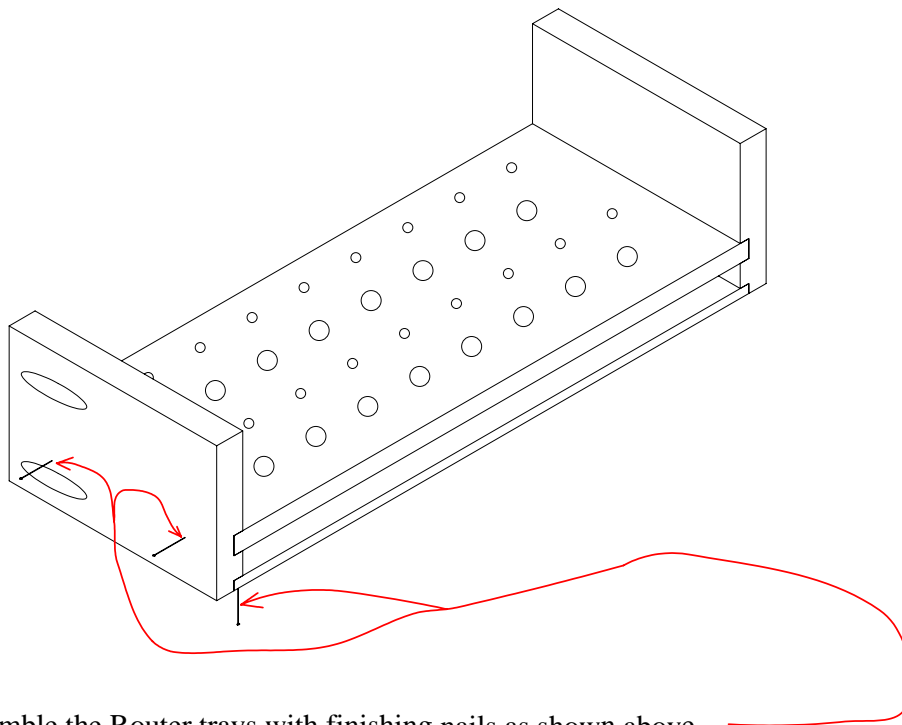

Assemble the Router trays with finishing nails as shown above.

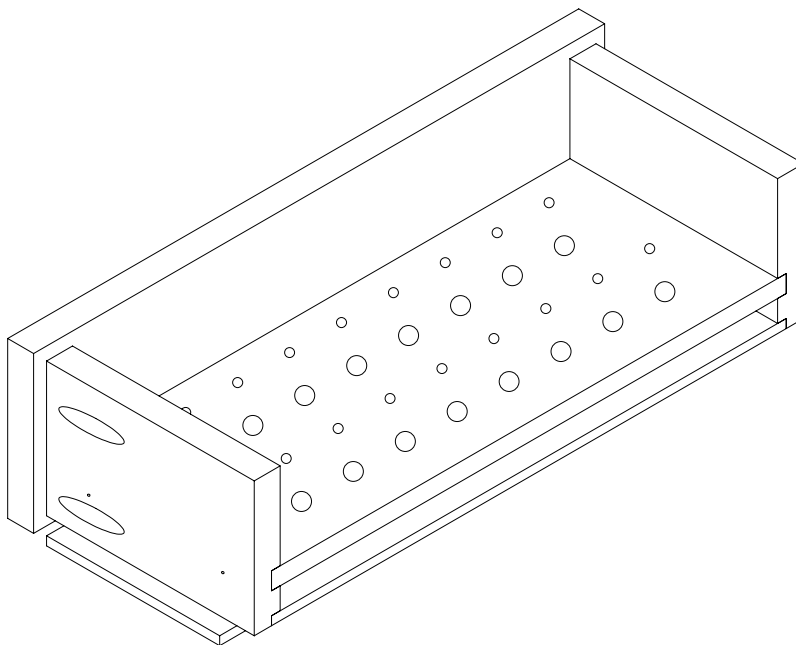

Attach the drawer fronts to the router tray fronts with pocket hole screws on each side as shown. Don't forget to support the trays with 1/4" thick strips of wood while you attach the fronts. As with the drawers, the bottom of the fronts must be 1/4" below the bottom of the trays so the fronts will overlap the cabinet trim when installed.

Attach the Cabinet Doors

Page 36

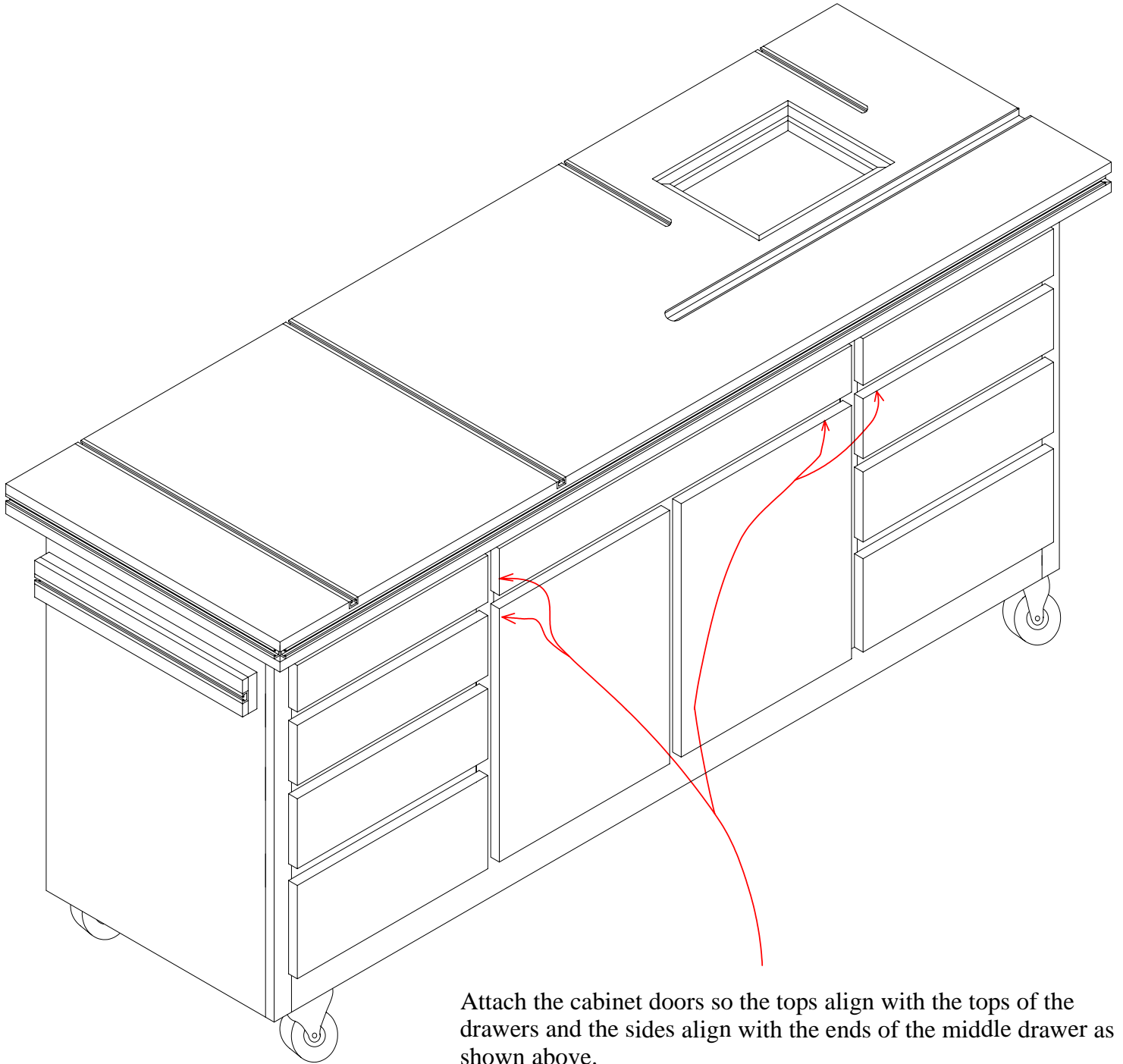

Attach the cabinet doors so the tops align with the tops of the drawers and the sides align with the ends of the middle drawer as shown above.

Attach the Middle Door trim

Page 37

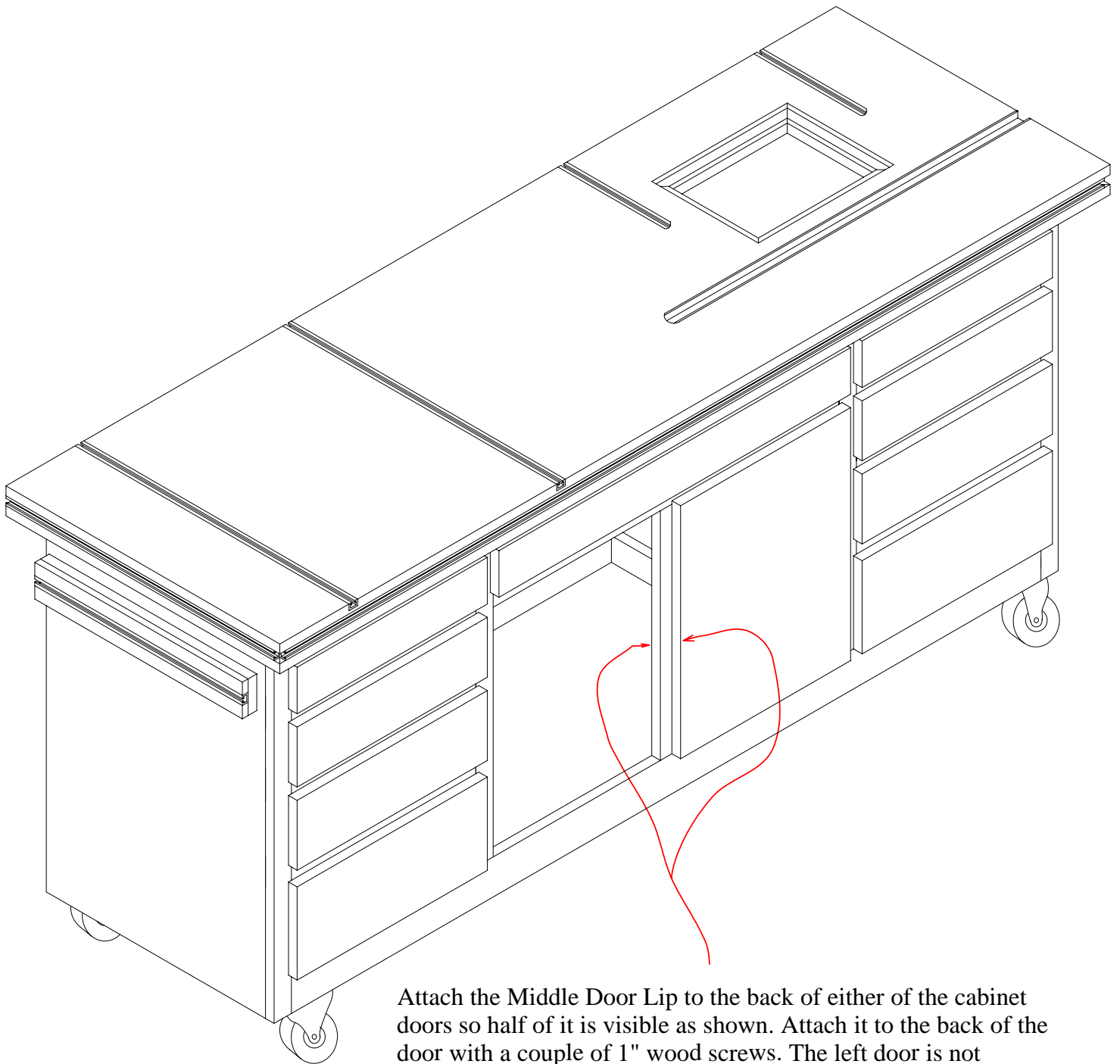

Attach the Middle Door Lip to the back of either of the cabinet doors so half of it is visible as shown. Attach it to the back of the door with a couple of 1" wood screws. The left door is not pictured in the drawing for clarity.

This piece serves as a door lip so there is no visible gap between the doors.

Now, you're ready to attach the Drawer and Door handles and your work bench is finished.

Clamping System Parts

Page 38

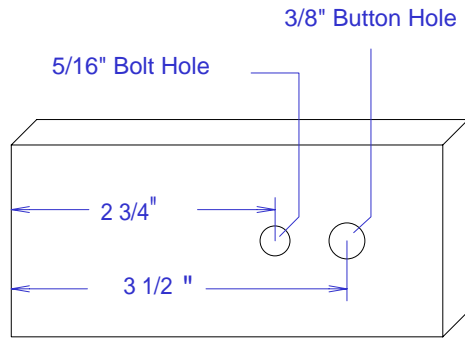
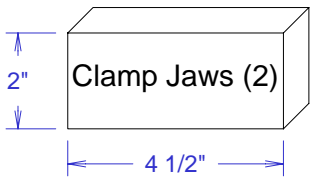

Clamp Jaw Layout (Side 1)

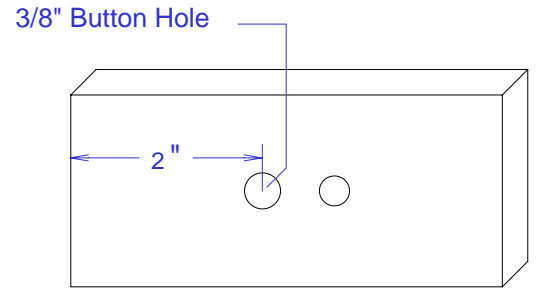

Clamp Jaw Layout (Side 2)

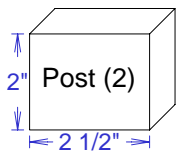
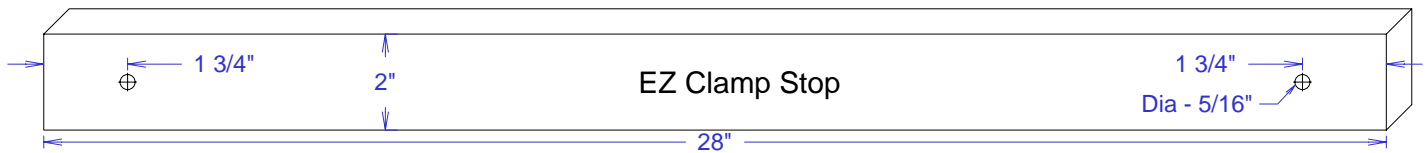

Drill two pocket holes in each Post as shown below. Next, drill two 1/4" diameter holes in the end of each Post as shown. (The 1/4" holes should only be 1/2" deep.)

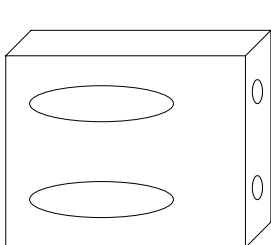
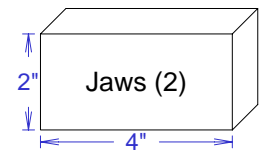

Posts

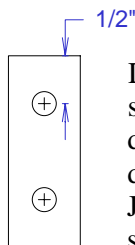

Drill a 5/16" bolt through each jaw as shown. Next, drill two 5/16" holes for the dowel pins in each Jaw as shown. (The dowel pin holes are 5/16" diameter so the Jaws can pivot over the pins. These holes should be 1/2" deep.)

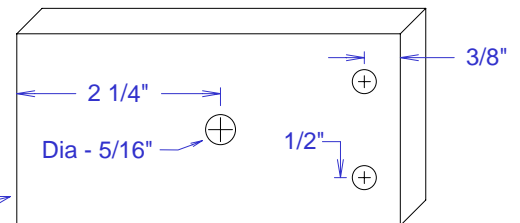

Jaws

Assemble the EZ Mount Stop

Page 39

Attach the Posts to the ends of the Stop Bar with pocket hole screws as shown below. Next, cut four $7/8$ " long dowel pins from $1/4$ " dowel rod. Apply some glue and insert a $1/4$ " dowel pin into each hole in the ends of the Posts. (The dowel pins should protrude about $3/8$ " from the ends of the Posts.)

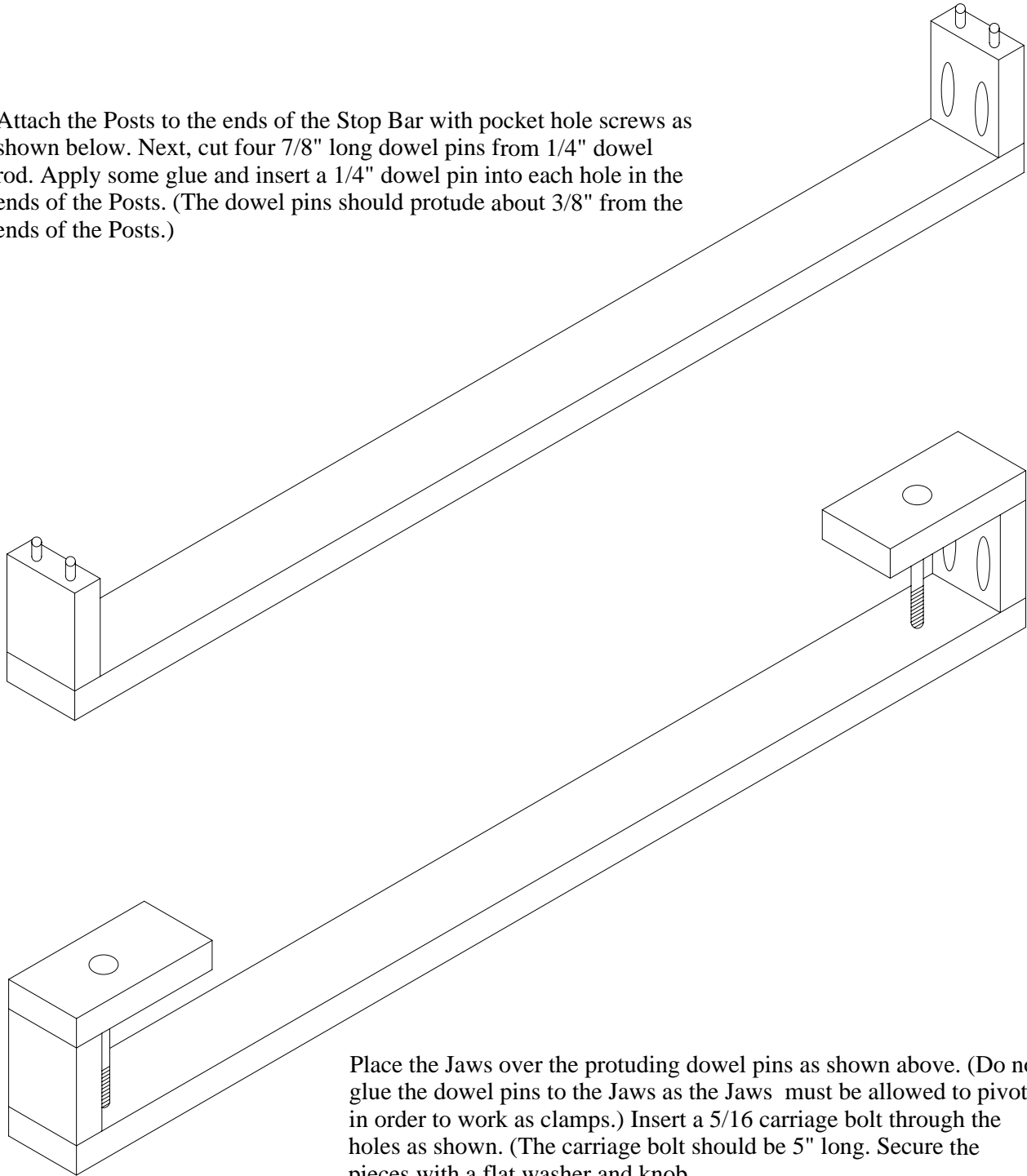

Place the Jaws over the protruding dowel pins as shown above. (Do not glue the dowel pins to the Jaws as the Jaws must be allowed to pivot in order to work as clamps.) Insert a $5/16$ carriage bolt through the holes as shown. (The carriage bolt should be 5" long. Secure the pieces with a flat washer and knob.

Clamping System Usage

Page 40

The T-Track clamping system provides a flexible way of clamping both large and small work pieces. Most work pieces can be clamped using the two Clamp Jaws and the Rear Stop. The Clamp Jaws are used with the T-Track that runs along the front edge of the workbench. The Rear Stop is used with the T-Track that is embedded in the top surface of the workbench.

For longer workpieces, you can use the the Clamp Jaws with the T-Track on the ends of the workbench. The EZ Mount Stop may be secured anywhere along the workbench top. The simple clamps on each end of the EZ Mount Stop grip the edge of the workbench top as well as C-Clamps. This feature enables you to use the workbench as a large bar clamp for gluing up boards.

You can make the clamping system grip the work piece even tighter by gluing strips of 100 grit sandpaper along the edges that contact the workpiece. The sandpaper requires much less force than the surface of bare wood.

The button arrangement on the Clamp Jaws allows you to flip the Clamp Jaws over for thicker work pieces. The drawings on the next two pages illustrates how the clamps work.

To clamp a work piece, position the workpiece so the edge protudes slightly over the edge of the workbench top as shown. Then, position the Rear Stop against the workpiece and tighten it to T-Track using the knobs. Next, tighten the Clamp Jaws against the workpiece with the knobs and your work piece will be clamped just like with a vice.

For thinner workpieces, position the Clamp Jaws and Rear Stop as shown. If your workpiece is thinner than 3/4", you can place strips of wood under the work piece so it is slightly higher than the top edges of the Clamp Jaws.

For thicker workpieces, flip the Clamp Jaws so the second button is against the Lower T-Track Trim and reverse the Rear Stop so the thicker edge is against the workpiece.

Using the Clamps

Page 41

For thinner workpieces, position the Clamp Jaws and Rear Stop as shown.

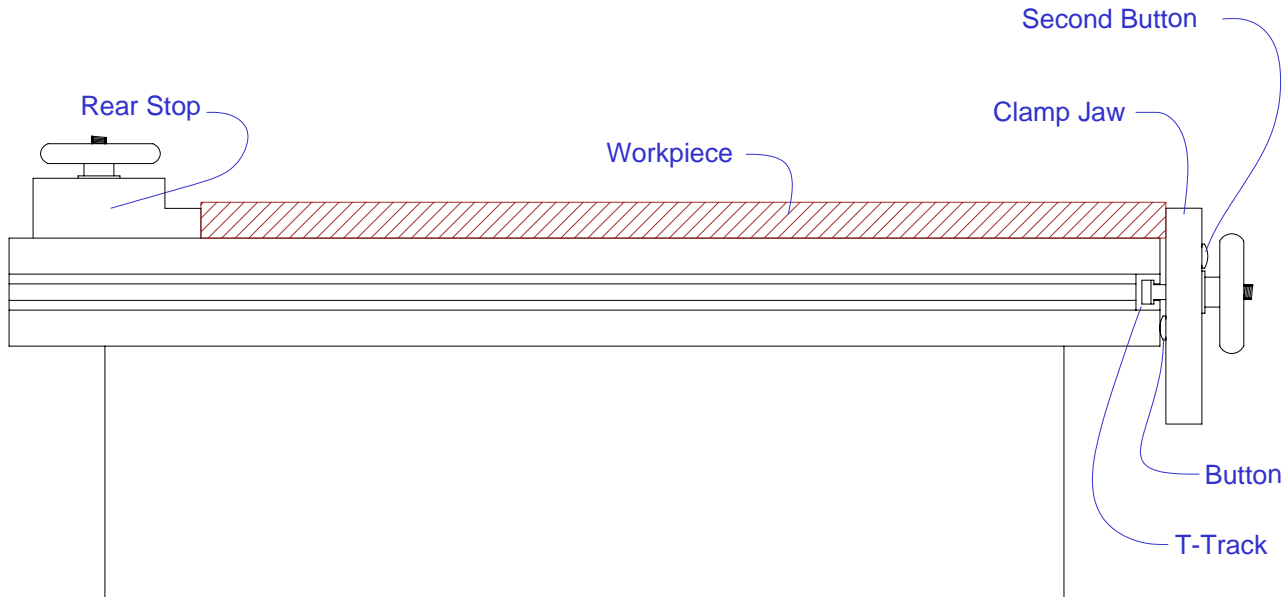

For thicker workpieces, flip the Clamp Jaw so the second button is against the Lower T-Track Trim and reverse the Rear Stop so the thicker edge is against the workpiece.

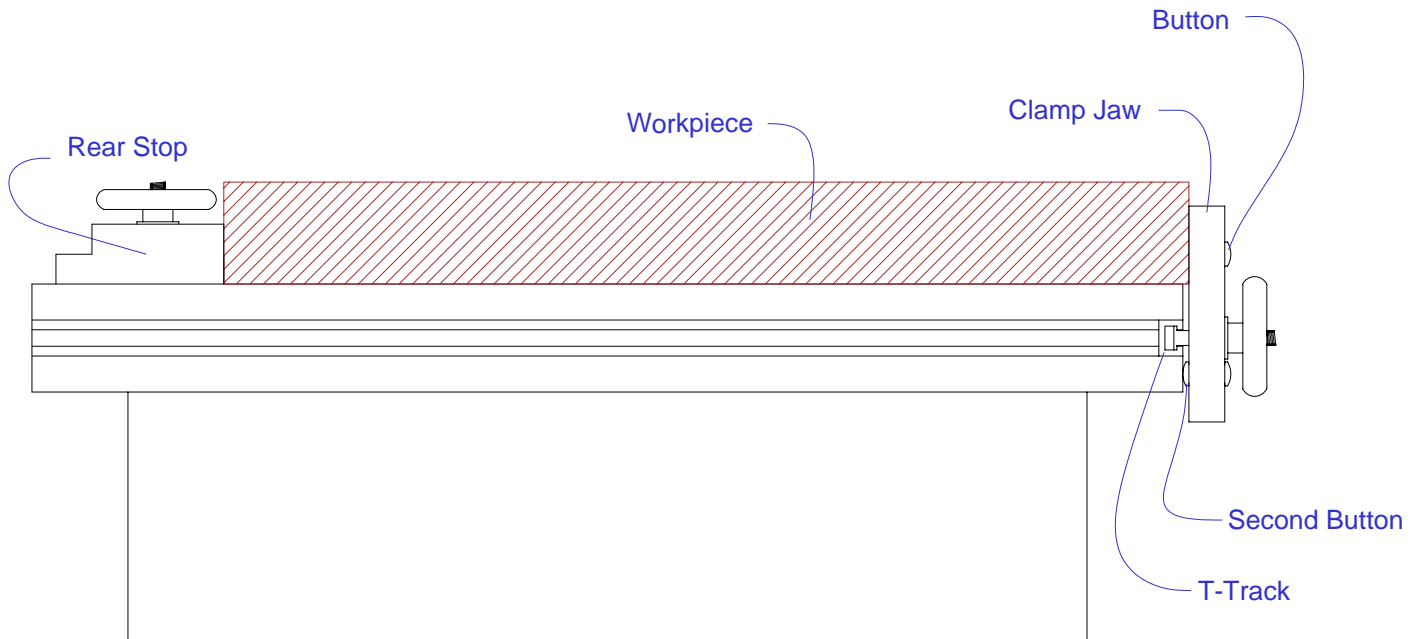

Clamping Long Workpieces

Page 41

To clamp long work pieces, use the Clamping Jaws and EZ Mount Stop as shown.

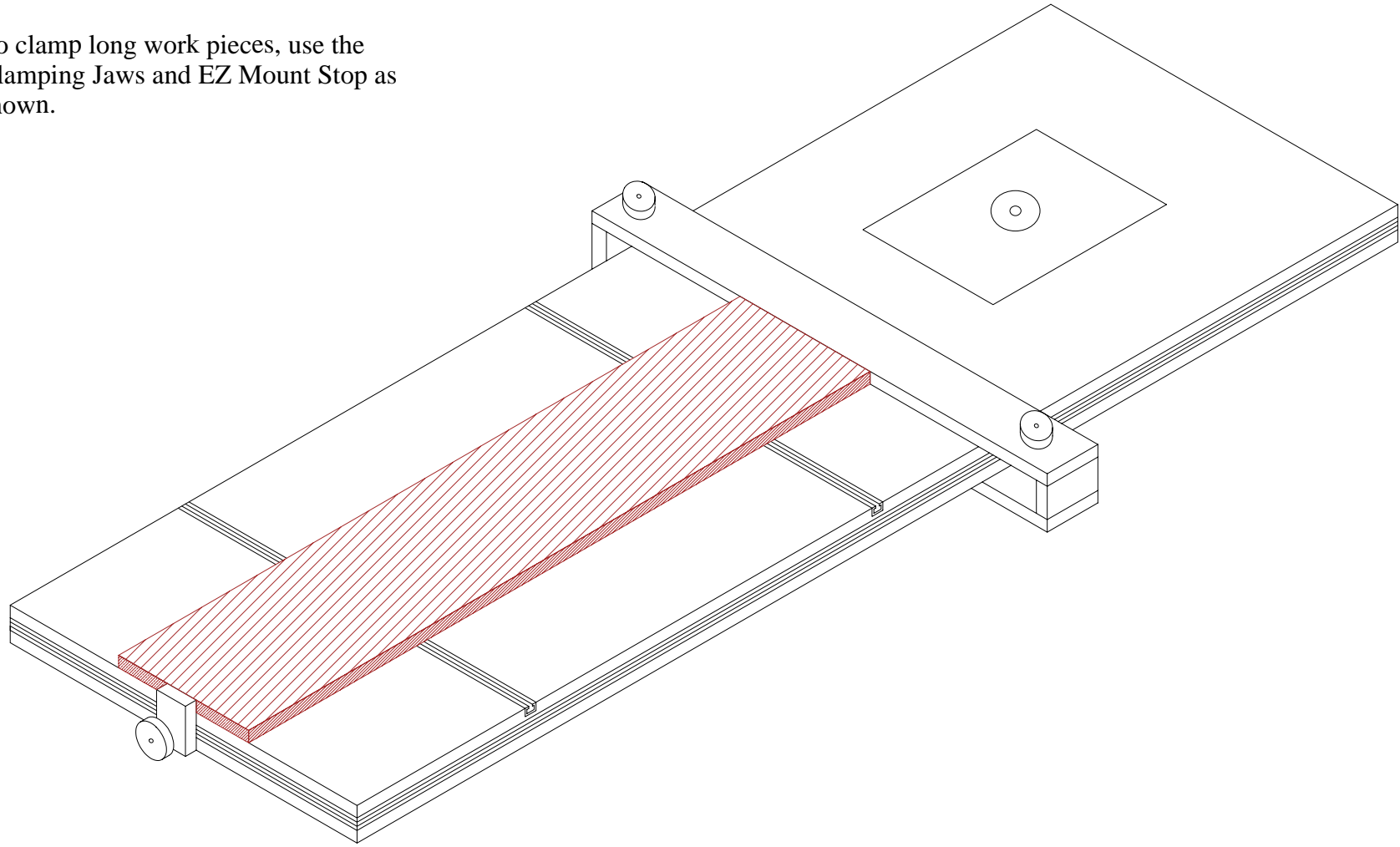

Snapshots



Clamping a small work piece



Clamping a large work piece



Clamping a thick work piece



Clamp a large work piece
Hold down clamps.

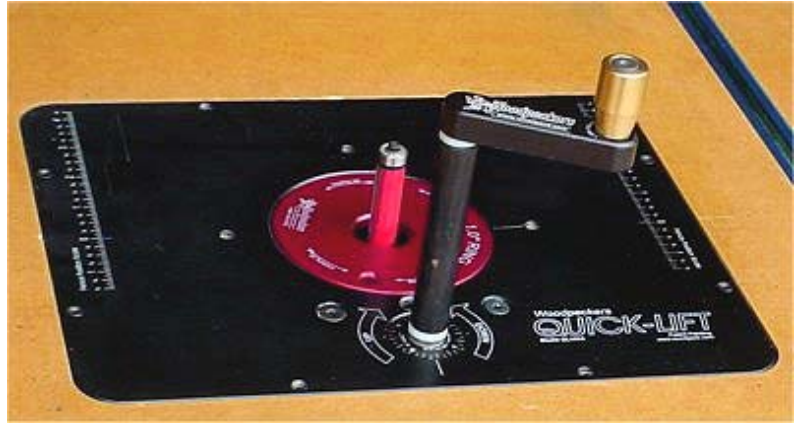

Close up view of the Woodpeckers Quick-Lift.



Clamping a work light.



Arranging the jaws for use with the EZ Mount Stop.
The purple edge is the 100 grit sandpaper used to
make the stop grip the work piece tighter.