



Wow! I Made It.com

## **L**awn Bench

*This versatile lawn bench can serve a multitude of purposes. We've used it as a bench for seating, as an outdoor coffee table, and even to hold a collection of plants. It's easy to make, and very sturdy when completed.*



### **Materials and Supplies**

- 30 linear feet of 1 x 4 pressure-treated pine
- 22 linear feet of 1 x 2 pressure-treated pine
- 10 linear feet of 2 x 3 pressure-treated pine

### **Hardware**

- 60 3d x 1-1/4" nails
- 15 4d x 1-1/2" nails
- 30 1-1/4" screws
- 30 1-5/8" screws
- 20 2-1/2" screws

## **Cutting List**

Code	Description	Qty.	Materials	Dimensions
A	Long Top	2	1 x 4 pine	53" long
B	Short Top	2	1 x 4 pine	14" long
C	Leg	4	2 x 2 pine	16-1/4" long
D	Long Inner Support	2	1 x 2 pine	48-1/2" long
E	Slat	14	1 x 4 pine	14" long
F	Leg Brace	2	2 x 2 pine	11" long
G	Lower support	2	1 x 2 pine	48-1/2" long
H	Spacer	3	1 x 2 pine	2-1/4" long

## ***Constructing the Bench Top***

1. Cut two long tops (A) from 1 x 4 pine, each measuring 53" long.
2. Cut two short tops (B) from 1 x 4 pine, each measuring 14" long.
3. Place the two short tops (B) between the ends of the long tops (A), as shown in *Figure 1*. Screw through the long tops (A) into the ends of the short tops (B), using two 1-5/8"-long screws on each joint.

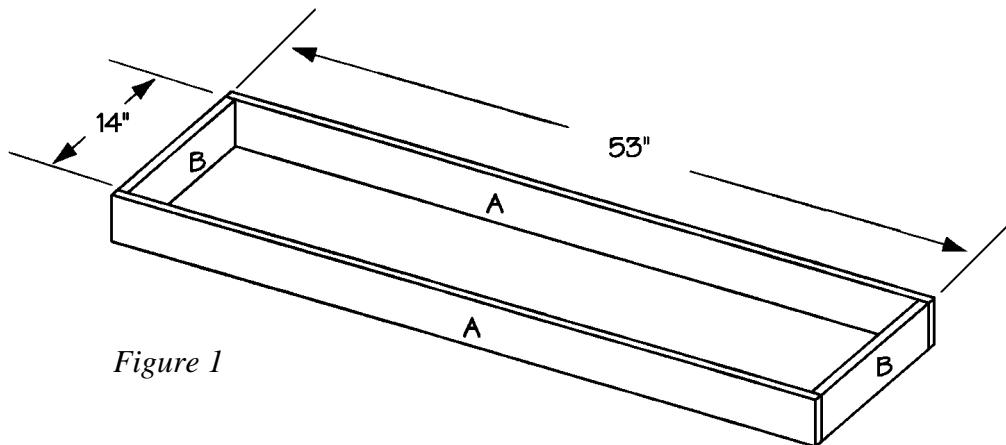
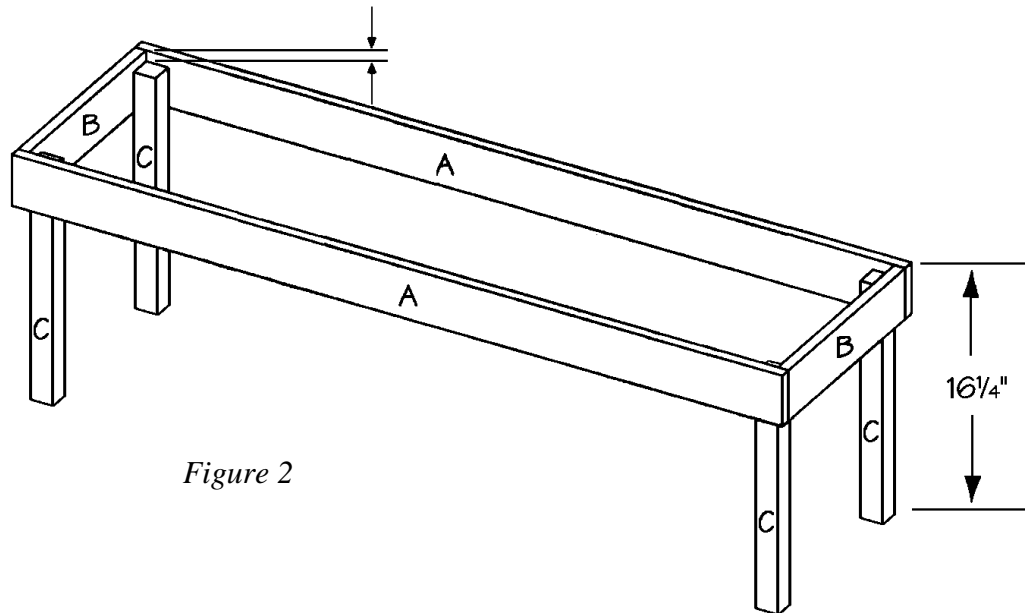

*Figure 1*

## ***Adding the Legs***

1. Cut four legs (C) from 2 x 2 pine, each measuring 16-1/4" long.

2. Attach each of the four legs to the four inner corners of the top assembly,  $\frac{3}{4}$ " from the top edges of the long and short tops (A and B), as shown in *Figure 2*. Screw through the long and short tops (A and B) into the legs (C), using two 1-5/8"-long screws in each side of the legs (C).



### ***Adding the Inner Supports***

1. Cut two long inner supports (D) from 1 x 2 pine, each measuring 48-1/2" long.
2. Attach one long inner support (D) to the inside of the one long top (A), as shown in *Figure 3*. It should be positioned flush with the top of the leg (C),  $\frac{3}{4}$ " from the top edge of the long top (A). Screw through the long inner support (D) into the long top (A), using 1-1/4" long screws, approximately every 6".
3. Repeat the previous two steps to attach the remaining long inner support (D) to the inside of the opposite long top (A).

### ***Adding the Slats***

1. Cut 14 slats (E) from 1 x 4 pine, each measuring 14" long.
2. Place the 14 slats (E) over the assembled inner supports, as shown in *Figure 4*. Space them evenly between the short tops (B), leaving a small space between slats. The exact measurement is not critical—just make certain that all the spaces are equal and that the slats are all straight. Nail through the ends of each of the slats into the long inner supports (D) and the legs (C), using two 1-1/4"-long nails on each end.

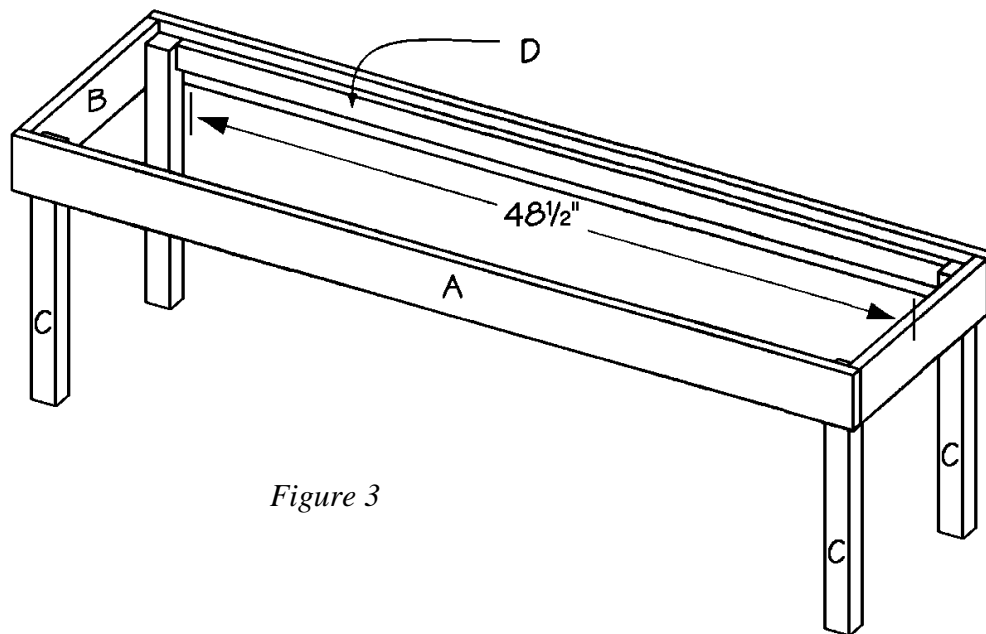

Figure 3

### **Adding the Leg Supports**

1. Cut two leg braces (F) from 2 x 2 pine, each measuring 11" long.
2. Attach a leg brace (F) between two of the legs (C), 8 inches from the bottom, as shown in *Figure 4*. Screw through the legs (C) into the ends of the leg braces (F), using two 2-1/2"-long screws on each joint.
3. Repeat Step 2 to attach the other leg brace (F) between the opposite legs (C).

### **Adding the Lower Support**

1. Cut two lower supports (G) from 1 x 2 pine, each measuring 48-1/2" long.
2. Cut three spacers (H) from 1 x 2 pine, each measuring 2-1/4" long.
3. Place the two lower supports (G) on a level surface, parallel to each other, and 2-1/2" apart. Fit the three spacers (H) evenly between the two lower supports, just over 11-1/2" apart, as shown in *Figure 5*.
4. Nail through the two lower supports (G) into the ends of the spacers (H). Use two 1-1/2"-long nails on each joint.
5. Fit the assembled lower support between the two leg braces (F), centering it on the braces. Screw through the leg braces (F) into the ends of the two lower supports (G). Use two 2-1/2"-long screws on each joint.

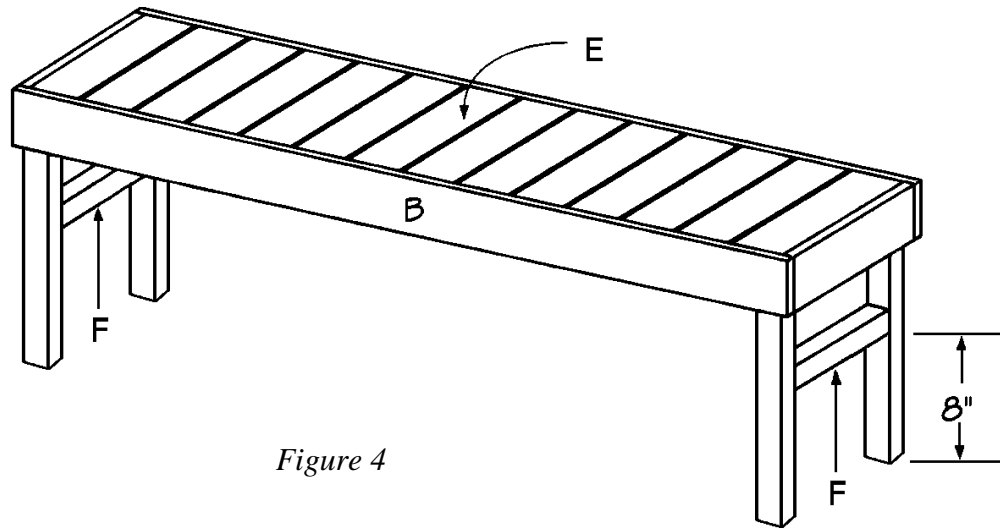

Figure 4

### **Finishing the Bench**

1. Fill any cracks, crevices, or screw holes with wood filler and thoroughly sand all surfaces of the lawn bench.
2. Seal and paint, or stain the completed bench the color of your choice. We left our project the natural color of the pressure-treated pine.

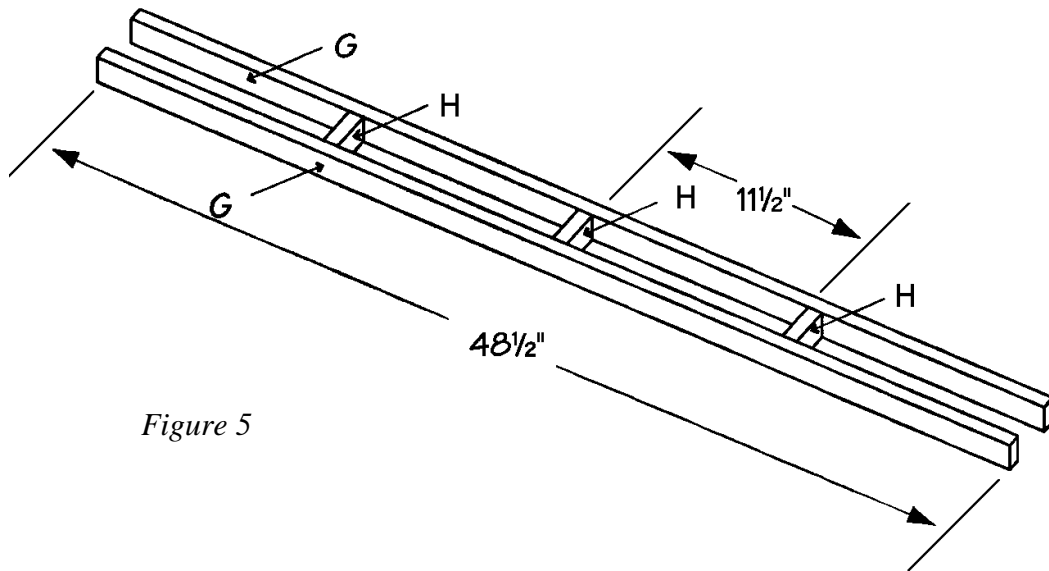

Figure 5