



Wow! I Made It.com

## Lawn Chair

*These simple-to-make chairs are a great addition to any backyard or deck—and even without a pillow, they are surprisingly comfortable. They are a great way to add seating to your backyard living space when you have very little time and money.*



## **Materials and Supplies**

- 17 linear feet of 2 x 4 pine
- 30 linear feet of 1 x 4 pine

## **Hardware**

- 95, 2-1/2" wood screws
- 4, 3-1/2" lag screws
- 4, 3-1/2" carriage bolts

## **Special Tools and Techniques**

- Bar clamps

## **Cutting List**

Code	Description	Qty.	Materials	Dimensions
A	Seat Front	1	2 x 4 pine	20" long
B	Seat Side	2	2 x 4 pine	19" long
C	Seat Slat	5	1 x 4 pine	20" long
D	Back Support	2	2 x 4 pine	14-1/2" long
E	Back	5	1 x 4 pine	20" long
F	Arm	2	1 x 4 pine	21" long
G	Arm Support	4	2 x 4 pine	24" long

## ***Building the Seat***

1. Cut one Seat Front (A) from 2 x 4 pine measuring 20 inches.
2. Cut two Seat Sides (B) from 2 x 4 pine, each measuring 19 inches.
3. Position the two Seat Sides (B) on edge, parallel to each other and 17 inches apart. Fit the Seat Front (A) over the ends of the Seat Sides (B), as shown in *Figure 1*. Apply glue to the meeting surfaces, and screw through the Seat Front (A) into the ends of the Seat Sides (B) using two 2-1/2" wood screws on each joint.

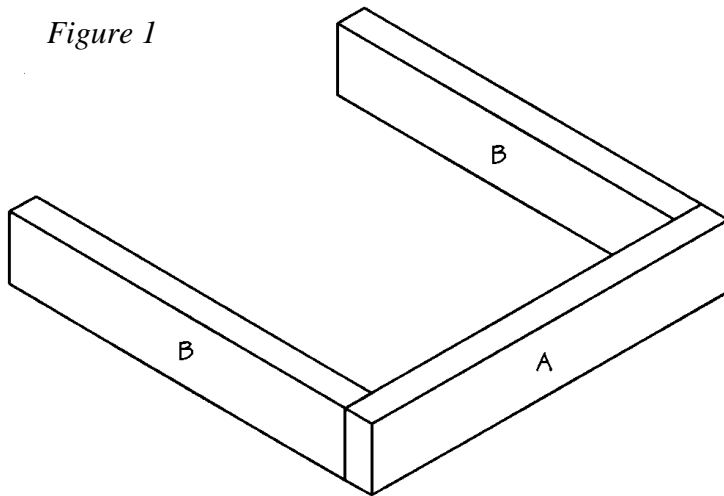

4. Cut five Seat Slats (C) from 1 x 4 pine, each measuring 20 inches.
5. Place the seat assembly [Seat Front (A) and Seat Sides (B)] on a flat surface. Position the five Seat Slats (D) over the assembly, as shown in *Figure 2*. The first Seat Slat (D) should be set back  $\frac{1}{2}$  inch from the face of the Seat Front (A),

and that the Seat Sides (B) should remain exposed at the other end. Screw through the Seat Slats (D) into the Seat Sides (B) using two 2-1/2" wood screws on each joint.

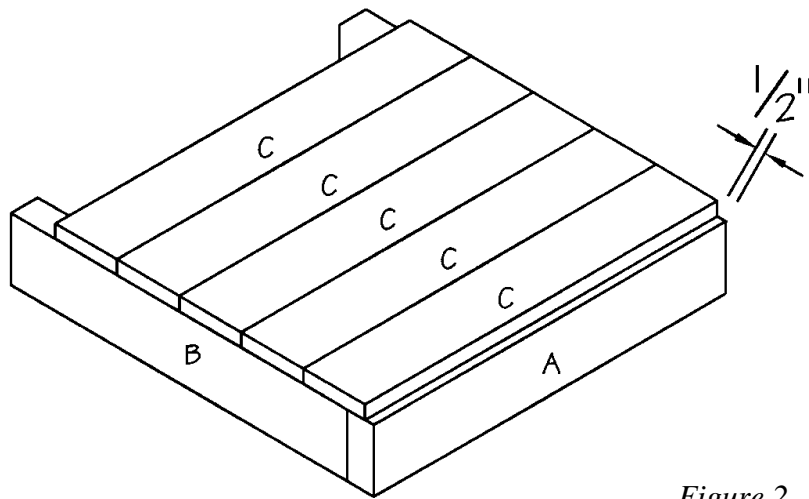

*Figure 2*

### ***Making the Back***

1. Cut two Back Supports (D) from 2 x 4 pine, each measuring 14-1/2 inches.
2. Cut five Backs (E) from 1 x 4 pine, each measuring 20 inches.
3. Position the two Back Supports (D) on a flat surface, parallel to each other and 13 inches apart. Position one Back (E) over the two Back Supports (D), as shown in *Figure 3*. The first Back (E) should overhang the ends of the two Back Supports (D) by 1 inch. Apply glue

to the meeting surfaces and screw through the Back (E) into each of the Back Supports (D), using two 2-1/2" wood screws on each joint.

- Repeat Step 3 four more times to attach the remaining four Backs (E) to the two Back Supports (D).

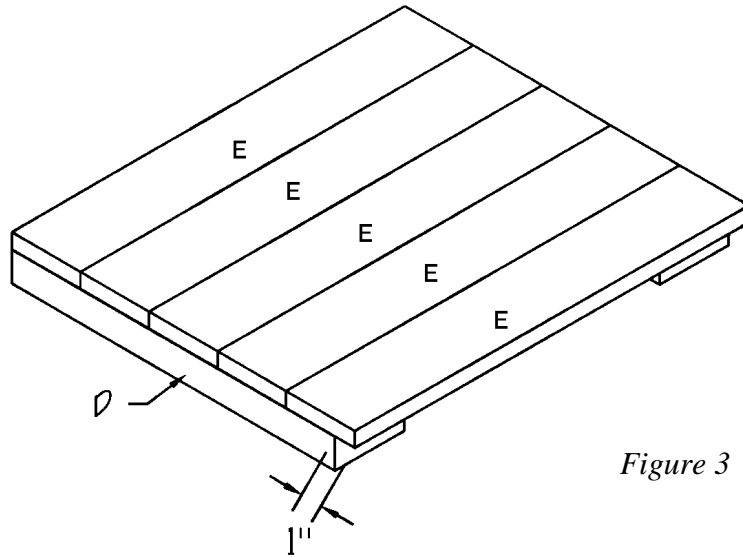

Figure 3

### ***Making the Sides***

- Cut two Arms (F) from 1 x 4 pine, each measuring 21 inches.
- Using *Figure 4* as a guide, shape the one Arm (F) by eliminating cutting off the shaded portions. Use the shaped Arm (F) as a pattern to cut the remaining Arm (F).
- Cut four Arm Supports (G) from 2 x 4 pine, each measuring 24 inches.

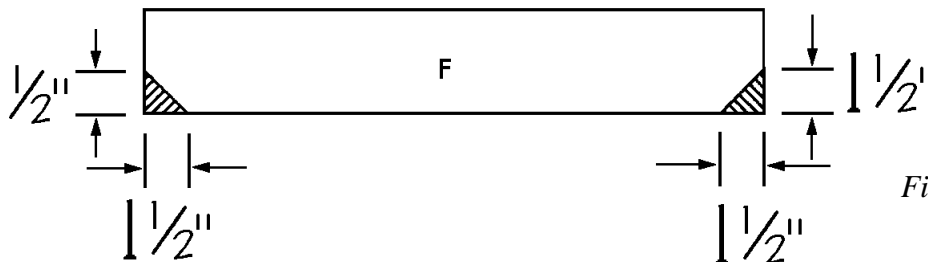
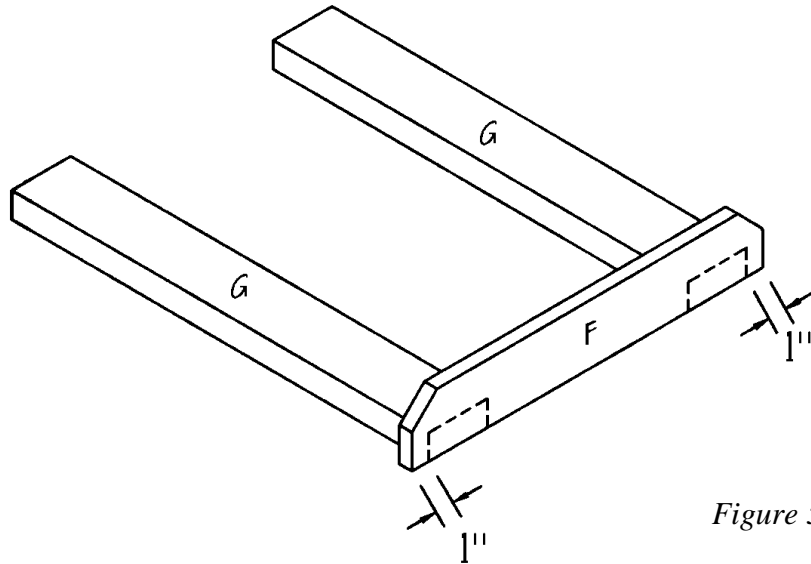

Figure 4

- Position two Arm Supports (G) face down on a level surface, parallel to each other and 12

inches apart. Place one Arm (F), uncut edge down over the ends of the two Arm Supports (G), as shown in *Figure 5*. The Arm (F) should overlap each of the Arm Supports (G) by 1 inch on each side. Apply glue to the meeting surfaces, and screw through the Arm (F) into the end of the Arm Supports (G) using two 2-1/2" wood screws on each joint.

5. Repeat Step 4 to construct another side using the remaining two Arm Supports (G) and the remaining Arm (F).



### ***Attaching the Arms***

1. Draw a line across the inside of each Arm Support (G), 18 inches from the unattached end. This will be the placement line for the next step.
2. This step is easier with a helper. The object is to clamp the assembled seat between the two side assemblies (as shown in *Figure 6*), and then to secure the seat with carriage bolts. The top of the seat should be positioned at the placement marks that you drew on the Arm Supports (G). The front Arm Supports (G) should be positioned 2 inches from the front of the seat assembly. When the sides are in position, clamp the two sides and seat assemblies tightly together using bar clamps.
3. Drill a hole slightly larger than the diameter of the 3-1/2" carriage bolt through the center of each of the Arm Supports (G) into the Seat Sides (B). Then insert a 3-1/2" carriage bolt through each of the holes. Tighten the bolts securely.

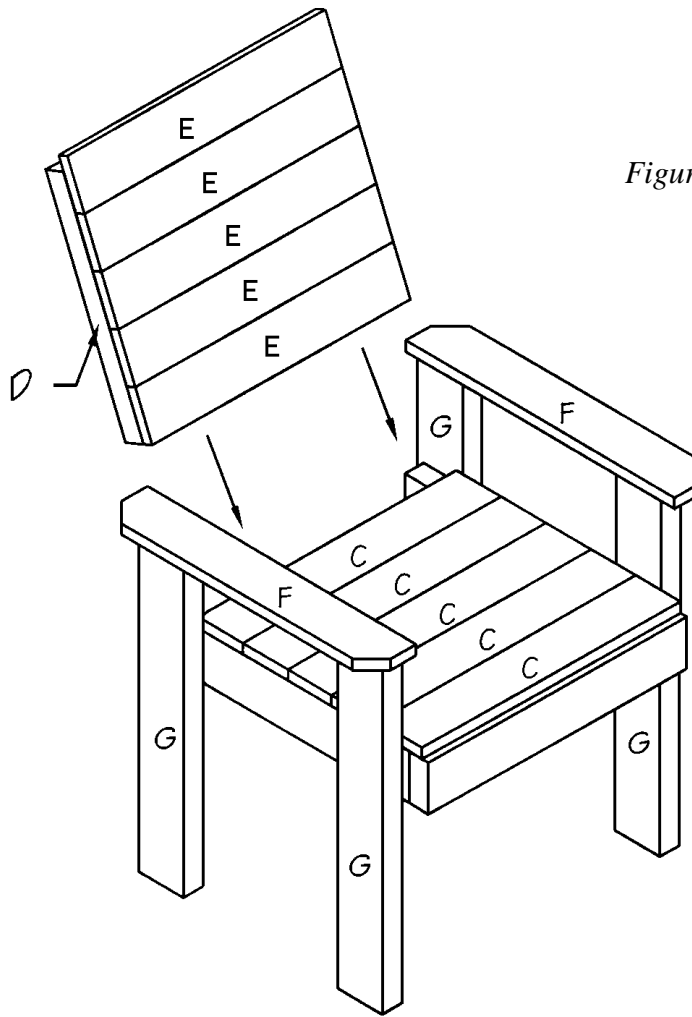

Figure 6

### ***Adding the Back***

1. Insert the back assembly between the two assembled sides. The Backs (E) should face the front of the chair, and the recessed end of the two Back Supports (D) should be at the top of the chair. To make the chair more comfortable, tilt the back assembly at a slight angle--out at the top and in at the bottom. The tilt angle is determined by the width of the 2 x 4 on the Arm Supports (G) and the back of the Arm (F).
2. When you have the back fitted perfectly, secure the assembly with bar clamps. Screw through the Arm Supports (H) into the Back Supports (E) using two 2-1/2" wood screws. Then insert a 3-1/2" lag screw through the Arm Supports (H) into the Back Supports (E).

## *Finishing*

1. Fill any cracks, crevices, or screw holes with wood filler.
2. Sand the completed chair thoroughly.
3. Paint or stain the chair the color of your choice--or simply leave it the natural color.



**Enjoy other indoor and outdoor projects from !**



When your friends and neighbors see your terrific backyard, they'll want to know where you got such customized outdoor furniture! Even if they're not experienced woodworkers, they'll find an easy project to get them hooked at !