

Build a Wooden Baby Cradle

This Wooden Baby Cradle is the perfect answer for where your precious new born will sleep. It can be placed in your bedroom so that you can better monitor your baby for the first few months until he/she is old enough to sleep in a crib.

This beautiful design will enhance your bedroom furniture. The design incorporates solid brass hinges and stop-pin features. Just slightly pull on the stop-pin and the cradle can be rocked. Push in the pin and the cradle is locked in place for safety.

Also, the end posts and stretcher can be disassembled for storage by easily removing four wood screws. You will feel a great sense of accomplishment as you construct this beautiful cradle. But I must warn you that your job will not end there. As your other children see this wood baby cradle they will want one for their own children as well.



BABY CRADLE

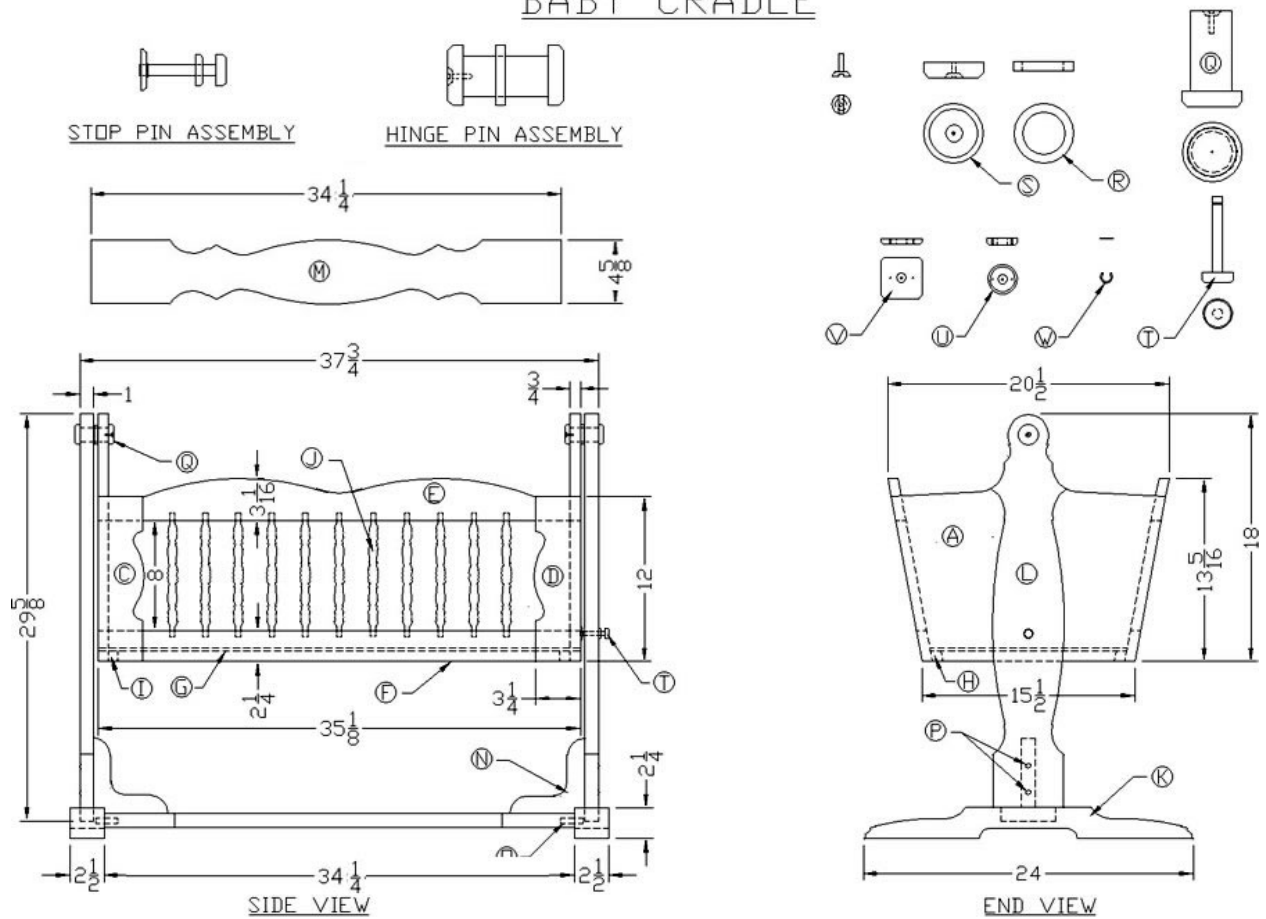

Technical Information for Making a Wooden Baby Cradle Plan

A. Materials List:

QUANTITY	LETTER	NAME	SIZE	MATERIAL
1	A	Headboard	3/4" x 18" x 20 1/2"	Oak
1	B	Footboard	3/4" x 18" x 20 1/2"	Oak

2	C	Left Stiles	$\frac{3}{4}'' \times 3 \frac{1}{4}'' \times 12''$	Oak
2	D	Right Stiles	$\frac{3}{4}'' \times 3 \frac{1}{4}'' \times 12''$	Oak
2	E	Top Side Rails	$\frac{3}{4}'' \times 3 \frac{1}{16}'' \times 35 \frac{1}{8}''$	Oak
2	F	Bottom Side Rails	$\frac{3}{4}'' \times 2 \frac{1}{4}'' \times 35 \frac{1}{8}''$	Oak
1	G	Cradle Bottom	$\frac{1}{4}'' \times 14'' \times 33 \frac{1}{2}''$	Oak
2	H	Bottom Side Braces	$\frac{3}{4}'' \times \frac{3}{4}'' \times 33 \frac{1}{2}''$	Oak
2	I	Bottom End Braces	$\frac{3}{4}'' \times \frac{3}{4}'' \times 33 \frac{1}{2}''$	Oak
22	J	Spindles	$\frac{3}{4}'' \times 9''$	Oak
2	K	Bases	$2 \frac{1}{2}'' \times 2 \frac{1}{4}'' \times 24''$	Oak
2	L	End Posts	$1'' \times 5 \frac{1}{8}'' \times 29 \frac{5}{8}''$	Oak
1	M	Stretcher	$1'' \times 4 \frac{5}{8}'' \times 34 \frac{1}{4}''$	Oak
2	N	Cleats	$1'' \times 5 \frac{1}{2}'' \times 5 \frac{1}{2}''$	Oak
10	O	Dowel Pins	$\frac{3}{8}'' \times 2''$	Birch
4	P	Buttons	$\frac{3}{8}''$ D.	Oak
8		Flathead Wood Screws	#10 x $1 \frac{1}{2}''$	Steel

2	Q	Hinge Pins	1" D. x 1 1/2" D. x 2 5/16"	Brass
2	R	Spacers	1/4" x 1 1/64" D. x 1 1/2" D.	Brass
2	S	Hinge pin Collars	1/4" x 1 1/2" D.	Brass
2		Flat Head Machine Screws	#10-32 x 3/4"	Brass
1	T	Stop Pin	1/4" D. x 3/4" D. x 2 1/8"	Brass
1	U	Stop Pin Collar	3/16" x 3/4" D.	Brass
1	V	Stop Pin Plate	1/8" x 1" x 1"	Brass
1	W	E-Ring	7/32"	Steel
4		Flat Head Wood Screws	#4 x 1/2"	Brass
		Finish Nails	1 1/2"	Steel
		Finish Nails	1/2"	Steel

WOOD SPECIES



Red Oak

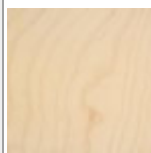

Birch

B. Pattern:

1. Scale Headboard A to the drawing dimension size. This can be accomplished by measuring the print out of the project and dividing that size into the dimension size shown on the drawing, or listed in the Bill of Materials. This will give a "Multi-Factor" that can be used to figure the enlargement size for the pattern.
2. Take the drawing printout and the multi-factor to a printing company. Most printing companies that do duplicating can make the enlargement required for the pattern.
3. The same multi-factor can be used to determine the enlargements for the other shapes C, D, E, K, L, M & N.
4. Trace the pattern enlargements onto poster board or Mylar and cut out the patterns with a pair of scissors.
5. Use these patterns to trace the shapes onto the wood stock.

C. Cutting Procedure:

1. Use 3/4" thick lumber for cradle and 1" thick lumber for cradle stand.
2. Use 1 1/4" thick lumber for base of cradle stand.
3. Use a radial arm or power miter saw to cut lumber to proper lengths, and a table saw to rip lumber to proper widths.
4. Use a jointer to remove all saw marks on lumber during the ripping procedure.
5. Dowel two 9 1/2" x 21" boards to make headboard (A). Place edges together and mark for dowel pin placements 2 1/2" from each end and in the middle. Using a dowel jig align the 3/8" hole with the marks and drill a 3/8" hole 1 1/8" deep into each board. Place wood glue on one half of each dowel pin and pound them into the holes using a wooden mallet. Place glue on edges and exposed dowel pins and clamp boards together using two bar clamps. Clean excess glue and to dry for 24 hours. Remove clamps and run through a planer to clean up each side.

6. Repeat step #5 to make footboard (B).
7. Trace patterns (A) & (B) onto lumber and cut out using a band saw and finish using a spindle sander.
8. Trace patterns for stiles (C) & (D) onto lumber and cut out design with a band saw and finish using a spindle sander. Place each stile (C) & (D) on a vacuum table and use a router and a 3/8" quarter round bit to route the design on each side of the boards in the pattern area.
9. Place dado blades on a radial arm saw and cut dado joints at the top/outer ends of stiles (C) & (D) 3/8" deep by 1 3/4" wide. Cut bottom/outer ends of the stiles 3/8" deep by 2 1/4" wide.
10. Use the radial arm saw and dado blades to cut dado joints at inner ends of the top and bottom side rails (E) & (F) 3/8" deep by 3 1/4" wide.
11. Spindles (J) can be turned on a wood lathe. Each spindle should be 3/4" Dia. x 9" long. The ends of each spindle should be 3/8" Dia. x 7/8" long. The spindle design can be your own creation. If you prefer to purchase the spindles, one choice may be #S7 made by Saunder Brothers, Inc. Most hardwood stores will have a source for them.
12. Mark top edge of bottom side rails (F) for centers of spindle holes. Spindle holes for #1 and #11 should be marked 2 1/8" from each stile and the other spindle holes should be marked 2 7/16" apart. Insert a 3/8" drill bit into the chuck of a drill press and adjust the drill depth to 7/8" and drill eleven holes in each bottom side rail.
13. Mark bottom edge of top side rails (E) for center of spindle holes the same as for the bottom side rails (F) in step #12. Drill the holes to 3/4" depth.
14. Cut cradle bottom (I) to fit after cradle has been assembled.
15. Use a table saw to cut bottom side and end braces (H) & (I) respectively to proper dimensions.

16. Trace patterns for end posts (L), stretcher (M), and cleats (N) onto lumber and cut out using a band saw and finish using a spindle sander.
17. Glue lumber together for bases (K) to get the required 2 1/2" width. Clamp and allow to dry for 24 hours. Trace base pattern onto lumber and cut out shapes with a band saw and finish with a spindle sander.
18. Measure and mark for a tenon at the bottom of each end post (L). The tenon should be 3/8" x 4" x 1 1/8" long. Use a radial arm saw and dado blades to cut the tenon. Chamfer the corners of the tenon slightly with a belt sander.
19. Measure and mark for a mortise at the top of each base (K). Use mortiser machine to cut each mortise 3/8" x 4" x 1 1/4" deep. When using hardwoods, pre-drill holes in marked area to aide in cutting the mortises. If mortise machine is not available, pre-drill holes and cut out mortises with a hammer and chisel.

D. Sanding Procedure:

1. Rough sand all parts with an orbital sander and 80 grit sandpaper.
2. Intermediate sand all parts with an orbital sander and 120 grit sandpaper.
3. Finish sand all parts with an orbital sander and 220 grit sandpaper.
4. Rough, intermediate, and finish sanding should be completed before assembling parts.
5. Hand sand with 220 grit sandpaper to slightly round all sharp edges.

E. Assembly Procedure:

1. Insert the spindles (J) into the bottom side rails (F) and use a wooden mallet to tap them into place. Place the top side rails (E) into place and insert the spindles into the holes. Place the stiles

(C) & (D) in place to form lap joints with the top and bottom rails. Place glue in the lap joints and use four bar clamps exert pressure until the top and bottom side rails (E) & (F) are clamped tight to the stiles. Square each unit with a t-square and then clamp each lap joint with a hand screw clamp. Clean up excess glue.

2. Glue and nail side assemblies onto the head and foot boards (A) & (B).
3. Glue and nail bottom side and end braces (H) & (I) flush with the bottoms of head and foot boards (A) & (B) and bottom side rails (F).
4. Cut the cradle bottom (G) to fit properly. Glue and nail bottom to side and end braces (H) & (I).
5. Place glue on the tenon of each end post (L) and in the mortise of each base (K) and secure end posts into the bases. Allow glue to dry for 24 hours.
6. Measure and mark for two dowel pins on inside of each base (K). Dowel pins should be placed 1" below the top of each base and spaced 4" apart. Use a drill press and a 3/8" drill bit to drill two holes 1 1/8" deep. Place glue on one half of each dowel pin and hammer into holes using a wooden mallet.
7. Mark both ends of stretcher (M) and drill 3/8" holes 4" apart and 1" deep to align with the dowel pins in the bases (K). Temporarily put stretcher in place and clamp tight with a bar clamp.
8. Place cleats (N) on stretcher (M) and mark each cleat for a notch at the 90 degree corner. Cut the cleat notches with a band saw. Use a t-square to make sure the end posts (L) are perfectly vertical when cleats (N) are in place. If not square, slightly change the cleat notch until it is square.
9. Clamp each cleat (N) in place with a hand screw clamp, and use #10 x 1 3/4" screw-mate counter bore and hand drill two holes 3 1/2" apart into the end posts (L) and the cleats, 1/4" below the surface.

10. Place glue on the cleat edge joining the end post and screw into place using #10 x 1 3/4" flathead wood screws.
11. Place a spot of glue on wood buttons (P) and tap into screw holes with a wooden mallet.
12. From the bottom of the stretcher (M) use the #10 x 1 3/4" screw-mate counter bore and hand drill two drill two holes through the stretcher and into the cleat (N) 3 1/2" apart and 1/4" below the surface. Use #10 x 1 3/4" flathead wood screws to secure each cleat to the stretcher. Do not use glue in this area. The cradle holder assembly is designed to come apart by removing the bottom screws in each end of the stretcher, allowing the base/end post assemblies to be taped off the stretcher. This provides for easier storage when the cradle is not needed.

Note: Additional sanding may be required after the side assemblies are attached to the head and foot boards.

F. Finish Procedure:

1. Use plastic wood dough, if needed, to fill any holes or cracks. Allow to dry Approximately 1 hour before sanding.
2. Hand sand wood dough with 220 grit sandpaper.
3. If stain is desired, apply with a brush and allow to penetrate for approximately 10 minutes, and then remove with a clean rag.
4. Allow stain to dry for 6 hours and then repeat with a second coat.
5. Apply a clear finish such as Lacquer, Varathane, Polyurethane, etc. using a pure-bristle brush. Allow to dry for 12 hours.
6. Lightly hand sand with 220 grit sandpaper.
7. Apply second coat of clear finish.
8. Allow to dry for 24 hours.

Notes:

1. Use a tack rag after each sanding procedure to remove the dust.
2. Match wood dough color to the stain color.
3. Do not allow stain to dry before removing with rag.
4. If paint is desired instead of a stain and clear finish, match the color of the wood dough to the wood color. Paint grade alder is recommended when using paint.
5. Most hardwoods are recommended for staining and/or clear finishes.

G. Manufacture Of Brass Hardware

1. Use a metal lathe to turn the hinge pins (Q), spacers (R), hinge pin collars (S), stop pin (T), and stop pin collar (U).
2. Cut stop pin plate (V) with a hacksaw and fillet each corner to 1/4" radius. File each edge and corner radius until smooth. Drill a 9/32" Dia. hole in center. Also drill a 1/8" hole on each side of center hole and bevel for flat head screws.
3. Spacers (R) should be drilled 1 1/64" Dia.
4. Stop pin collar (U) should be drilled 9/32" Dia. Also drill a 1/8" hole on each side of the center hole and bevel for flat head screws.
5. Drill 13/64" hole in center of hinge pin collars (S). Bevel for flathead machine screw.
6. Tap a 10-32 x 3/4" thread in the end of each hinge pin (Q).
7. Use the metal lathe to cut a 7/16" Dia groove in the stop pin (T) for the E-ring (W), 1/8" from the end.
8. Buff and polish all metal edges to remove burrs and rough surfaces.
9. Spray all brass hardware with lacquer or other clear finish to protect from corrosion.

Notes:

1. If you don't have access to a metal lathe, any machine shop can manufacture the brass hardware for you. The brass screws can be purchased at a hardware store.
2. You may also use a 1" hardwood dowel rod in place of brass pin hinges. The wooden dowel hinges should be secured in place with wood screws.
3. A 1/4" dowel rod can be substituted for the brass stop pin.

H. Installation of Brass Hardware:

1. Scribe centers of head/foot boards (A) & (B) and end posts (L). Use a drill press and a 1" Forstner bit to drill holes in the head/foot boards and end posts. Place wax inside holes to prevent squeaks and aid in insertion of hinge pin (Q).
2. Insert a hinge pin (Q) through the hole in the end post (L), then slip a spacer (R) between the end post and the headboard and continue to push the hinge pin through the spacer and the headboard. Repeat process for the opposite side. The hinge pins and spacers can be put in place simultaneously with two people. Place the hinge pin collars (S) in position and secure to the hinge pins using the brass flathead machine screws.
3. Mark on right end post 2" up from the bottom of the cradle for the stop pin placement.
4. Drill a 9/32" hole through the end post (L) and continue to drill the hole into the headboard (A) approximately 1/8" deep.
5. Center stop pin collar (U) over the hole in the end post (L) and use brass wood screws to secure into position.
6. Center stop pin plate (V) over hole in headboard (A) and use brass wood screws to secure into position.
7. Insert stop pin (T) through the stop pin collar (U) and the stop pin plate (V) and clip the E-ring (W) into the groove in the stop pin. Move the stop pin out when you want to swing the cradle. Push

the stop pin in when you want to lock the cradle. The E-ring will prevent the stop pin from pulling all the way out.

***Congratulations, your Wooden Baby Cradle is finished and ready to use!**