

192

PARSONS TABLE



This parsons table offers a surface area of 19-1/4 square feet. By adding two table extensions, you can increase the surface area to more than 32 square feet. Either way you choose to build it, the table is sure to be a welcome addition to your dining room or kitchen.

1. Cut all pieces to size according to the dimensions given.
2. Drill 3/8"-diameter dowel holes in the legs, side rails (D) and end rails (C), as shown.

3. Construct the frame (C,E,F) using 6d finishing nails, then nail and glue the top (A) in place. Be sure to fill all nail holes with wood putty.

4. Assemble the legs and side rails (D) with 3/8"-diameter x 2" dowels, glue, and screws (see Detail A).

NOTE: Steps 5 and 6 deal with tables that have extensions.

5. The extension table has shorter end rails (C) to allow the extension supports (G) to extend out from the ends. The supports receive the

extensions as shown.

6. Drill four 9/16"-diameter holes in each extension support and matching holes in the brackets (H). When the supports are mounted to the brackets in the extended position, use two or more 1/4" x 2" stove bolts with wing nuts to secure each support.

7. Sand all surfaces. Cover with plastic laminate or finish to suit your taste.

LIST OF MATERIALS (Table without Extensions)

(finished dimensions in inches)

A Top	3/4 x 42 x 66
B Legs (4)	3 x 3 x 28-1/4
C End rails (2)	3/4 x 2-1/4 x 36
D Side rails (2)	3/4 x 2-1/4 x 60
E Inner rails (2)	3/4 x 2-1/4 x 64-1/2
F Center rail	3/4 x 2-1/4 x 34-1/2
Dowels	3/8 dia. x 2
Flathead wood screws	#10 x 2
Roundhead wood screws	#10 x 2
6d finishing nails	
Wood putty	
Wood glue	

LIST OF MATERIALS (Table with Extensions)

(finished dimensions in inches)

A Top	3/4 x 42 x 66
B Legs (4)	3 x 3 x 28-1/4
C End rails (2)	3/4 x 2-1/4 x 32-7/8
D Side rails (2)	3/4 x 2-1/4 x 60
E Inner rails (2)	3/4 x 2-1/4 x 66
F Center rail	3/4 x 2-1/4 x 34-1/2
G Extension supports (4)	3/4 x 2-1/4 x 32-3/4
H Brackets (8)	3/4 x 2 x 16
J Extension side rails (2)	3/4 x 2-1/4 x 42
K Extension end rails (4)	3/4 x 2-1/4 x 22-1/4
L Extension tops (2)	3/4 x 23 x 42
Dowels	3/8 dia. x 2
Stove bolts	1/4 dia. x 2
Washers and wing nuts	1/4 dia.
Roundhead wood screws	#10 x 1-1/2
6d finishing nails	
Wood putty	
Wood glue	

FRAME ASSEMBLY DIAGRAM
(WITHOUT EXTENSION)

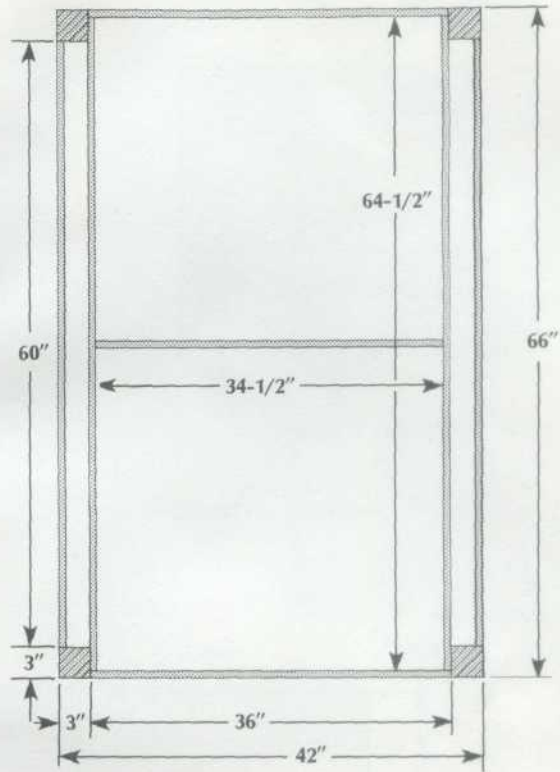
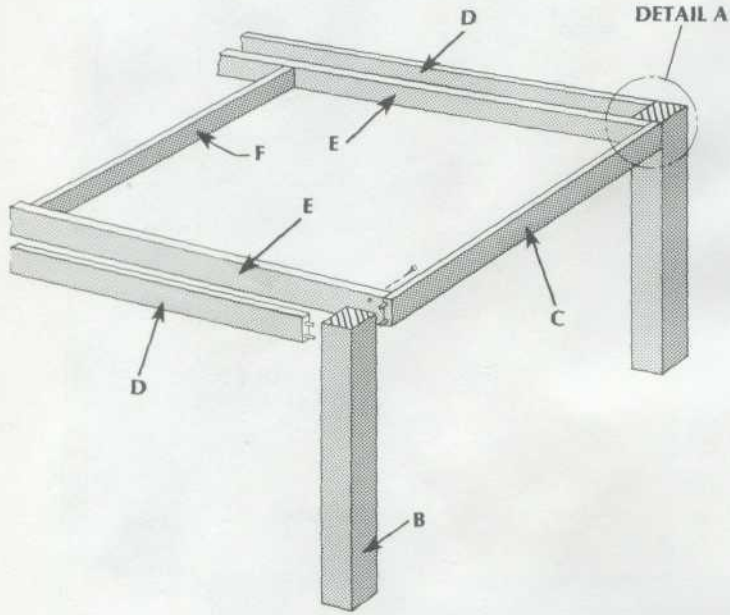

FRAME ASSEMBLY DIAGRAM
(WITH EXTENSION)

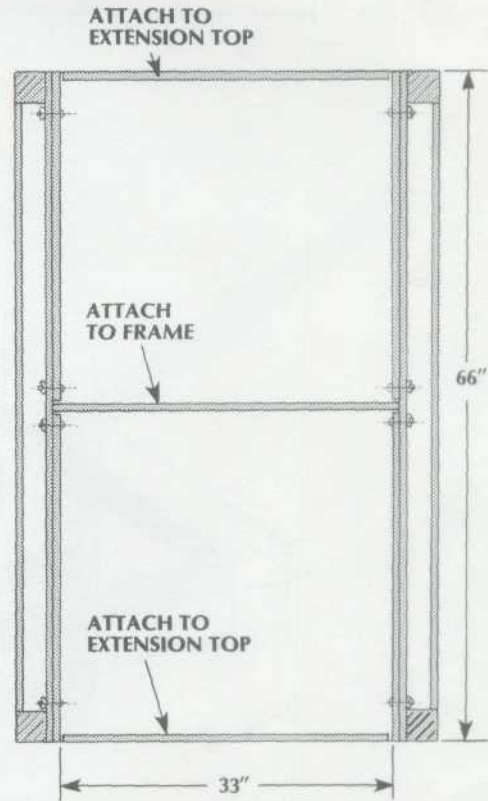
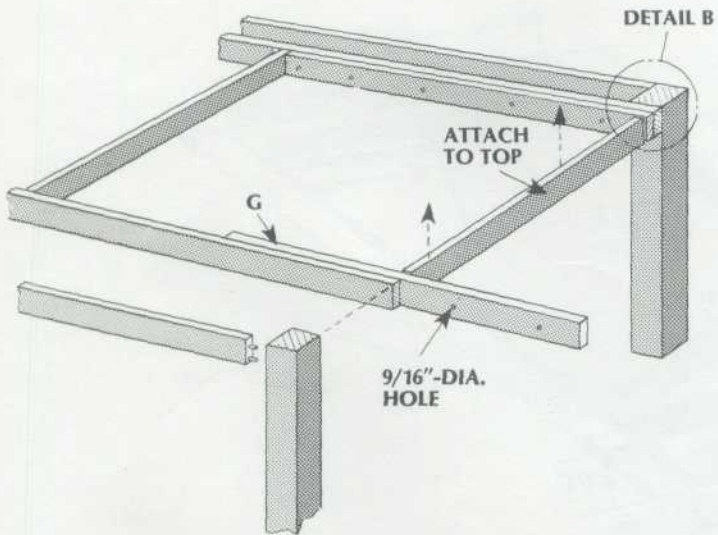

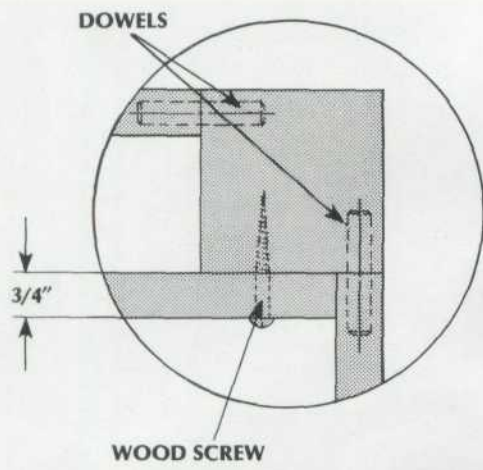

**DETAIL A
(WITHOUT EXTENSION)**

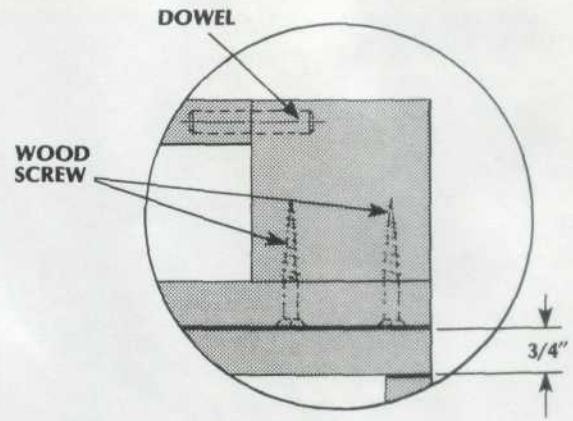

**DETAIL B
(WITH EXTENSION)**

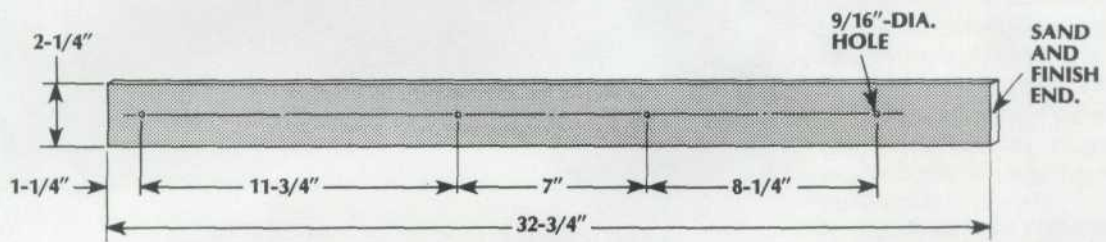

**EXTENSION
SUPPORT (G)**

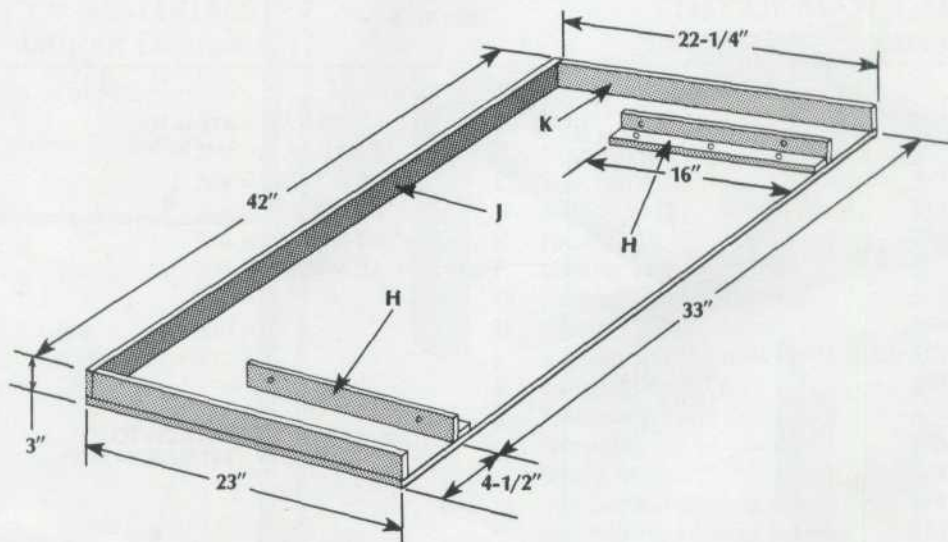

**EXTENSION
DETAIL**

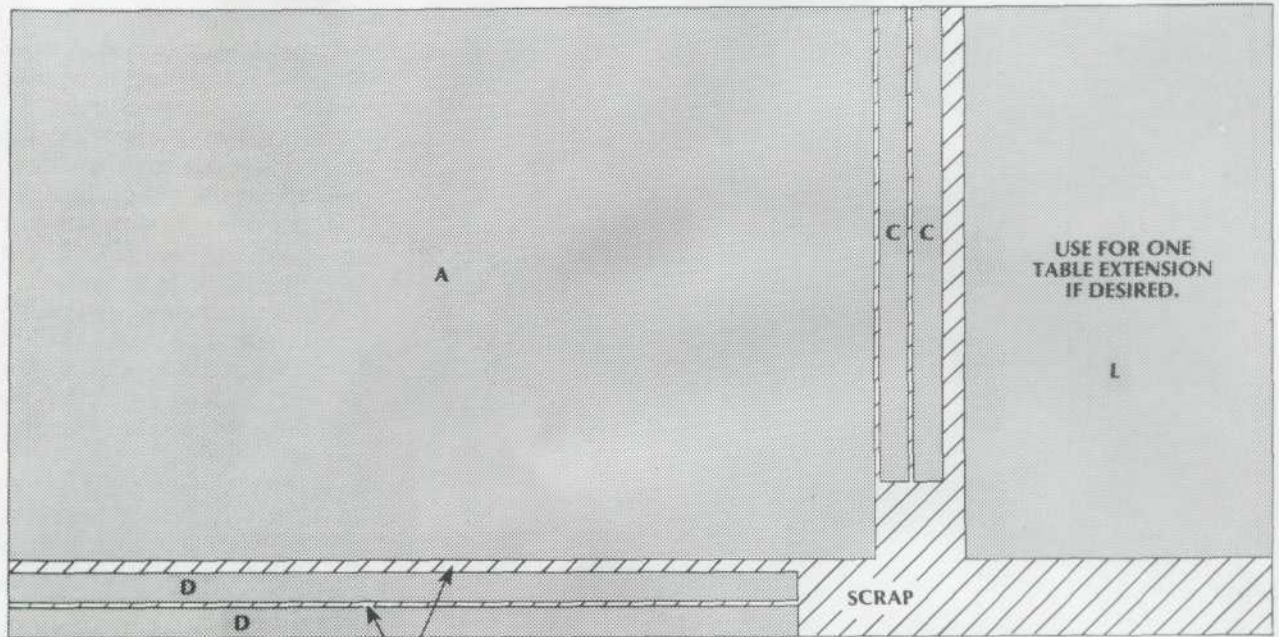

NOTE: AMPLE ALLOWANCE NEEDED FOR SAW KERF.

3/4" x 4' x 8' PLYWOOD CUTTING LAYOUT

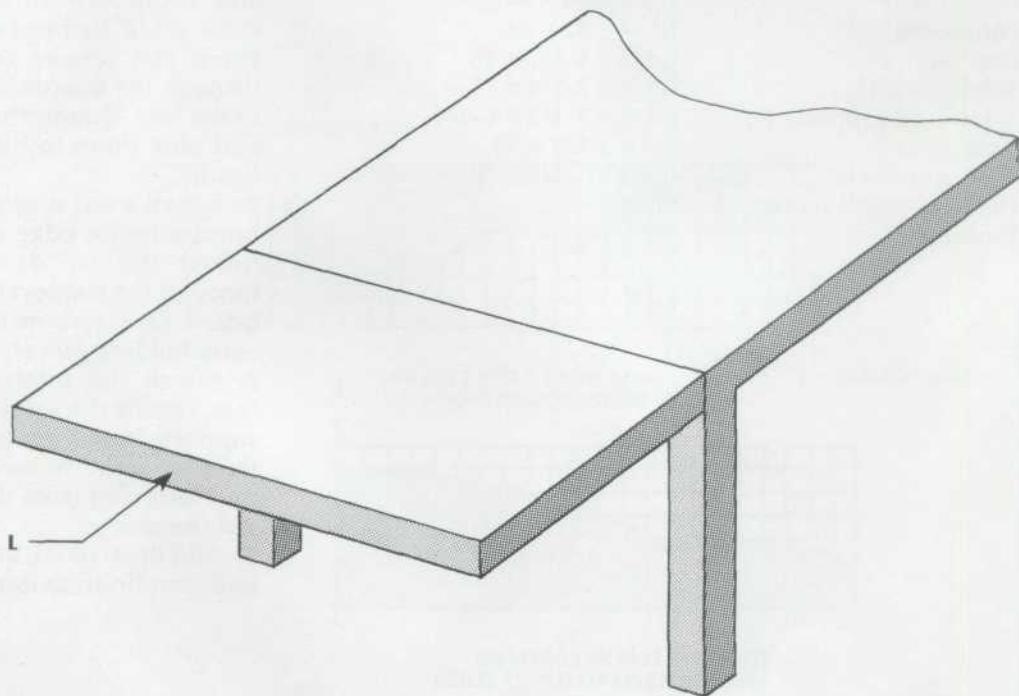

TABLE EXTENSION IN MOUNTED POSITION