

77

GARDEN SWING

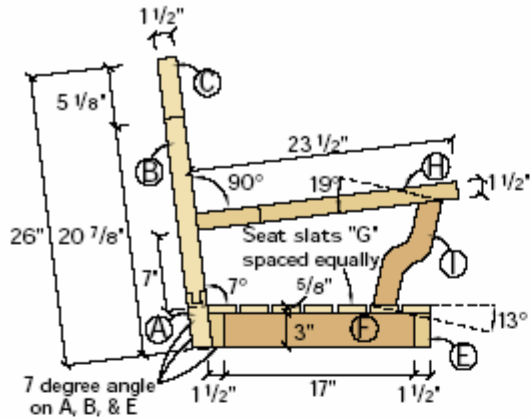



Schedule of Materials: Garden Swing

| No. | Ltr. | Item | Dimensions T W L | Material |
|-----|------|---------------------|---------------------------|----------|
| 1 | A | Bottom back rail | 1 1/2" x 5" x 55" | Cedar |
| 2 | B | Back stiles | 1 1/2" x 2 1/2" x 20 7/8" | Cedar |
| 1 | C | Top back rail | 1 1/2" x 8" x 60" | Cedar |
| 11 | D | Back slats | 5/8" x 2 1/2" x 20 1/2" | Cedar |
| 2 | E | Seat rails | 1 1/2" x 3" x 60" | Cedar |
| 4 | F | Seat stringers | 1 1/2" x 3" x 17" | Cedar |
| 21 | G | Seat slats | 5/8" x 2 1/2" x 20" | Cedar |
| 2 | H | Arms | 1 1/4" x 3" x 23 1/2" | Cedar |
| 2 | I | Arm supports | 1 1/2" x 4" x 12" | Cedar |
| 2 | J | Table battens | 3/4" x 1 1/2" x 19 7/8" | Cedar |
| 2 | K | Table legs | 1" x 1 1/4" x 6 1/2" | Cedar |
| 2 | L | Table legs | 1" x 1 1/4" x 8 1/4" | Cedar |
| 2 | M | Table leg braces | 5/8" x 1 1/4" x 13" | Cedar |
| 2 | N | Table support seats | 1" x 2" x 20" | Cedar |

*Longest slat, cut to fit. **Length oversize to allow fitting.

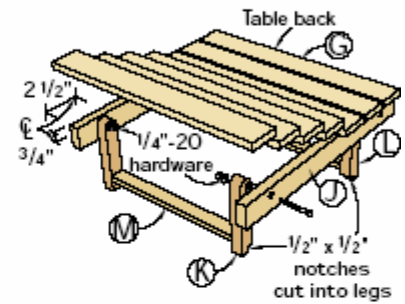
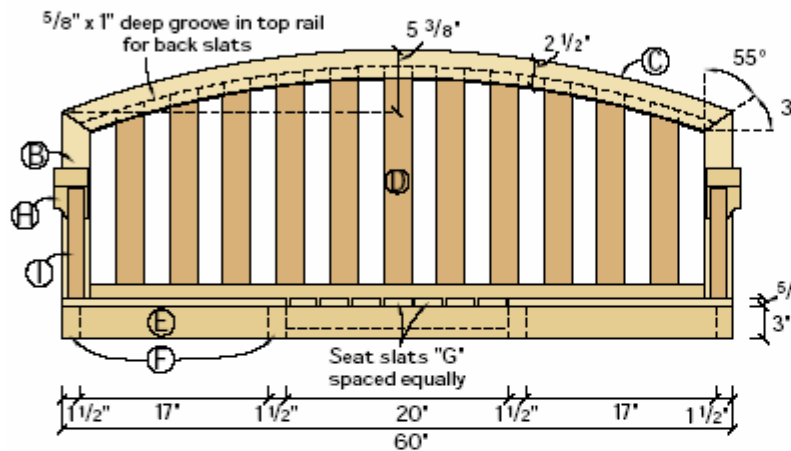

Schedule of Materials: Swing A-Frame

| No. | Item | Dim. T W L | Material |
|-----|-------------------------------|-------------|----------|
| 4 | Frame legs | 4 x 4 x 96" | PTP |
| 1 | Top center rail | 4 x 4 x 96" | PTP |
| 2 | Top outer rails | 2 x 4 x 96" | PTP |
| 2 | Leg supports | 2 x 6 x 48" | PTP |
| 4 | Swing-N-Slide EZ Frame Braces | | |
| 4 | Swing-N-Slide Leg top braces | | |
| 2 | 3/8" x 6" eye bolts | | |
| 4 | 3/8" flat washers | | |
| 4 | 3/8" nuts | | |
| 8 | S-connectors | | |
| 4 | 6-foot lengths of chain | | |

PTP = pressure treated pine

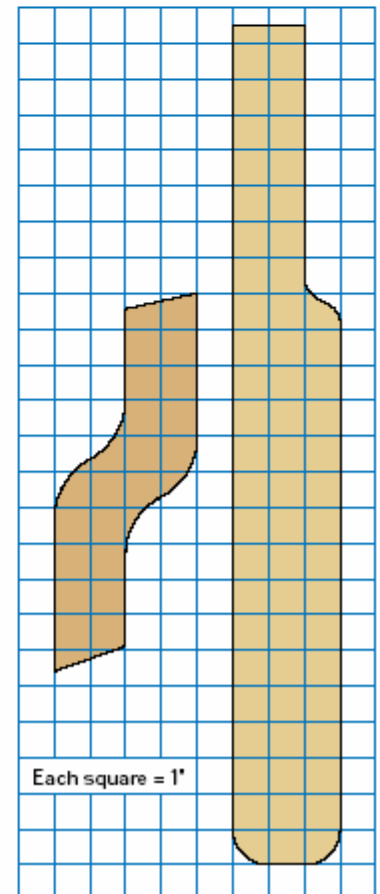

Start the project by heading to the lumber yard. The six-foot swing as shown required one 2x8, one 2x6, five 2x4s, and 10 1x4s all in eight-foot lengths. I chose western red cedar because it's a durable, lightweight, outdoor wood and is less expensive than redwood. At Midwest prices, the lumber cost about \$120.

Seat Frame

Once back in the shop, start construction by cutting the seat rails and stringers from the 2x4s. As you probably know, dimensional lumber comes with rounded edges. You'll need to get rid of them. Cut the pieces for the rails and stringers to their 3" thickness by first running one edge over the jointer until they have a square edge, then rip them to 3" wide. To give the seat a comfortable back angle, set your saw blade to an 7-degree bevel and run the back rail on edge to give a 7-degree angle to the back.

Now cut the pieces to length and screw the stringers between the rails, spacing them as shown. The center section spacing is critical because the pop-up table needs to be square so it can be lifted out and turned in place and the legs lowered. Use 2" galvanized deck screws when screwing the seat frame together.

Mill all the slats at the same time because they are essentially the same size. Cut the 1x4s into 24" lengths, and plane the boards to 5/8" thickness. Then rip them to their 2½" width and crosscut the seat slats to 20". To give the swing a finished look, cut an 1/8" roundover on all four top edges of each seat slat using a bit mounted in a router table.

Attach the slats for the permanent seats, running the slats from side to side. They should flush up in length to the outside edges of the stringers, and the front slat should be flush to the front rail. Use about 3/8" spacing between the slats. I decided to attach the slats to the frame using finish nails and an air nailer. This left a much smaller hole than screws, and it was very quick.

To finish the seat I decided to build the top surface of the table at this point. The spacing works the same as on the side seats, but run the slats from front to back. The slats are attached to two table battens (¾" x 1-½" x 19-7/8") that are held 1/16" or so away from the inside face of the front and rear rails. This gap should allow the table to lift out without binding, but some slight fitting may be necessary. Don't worry about the legs yet, we'll do that later.

Build the Back

Next, turn to the back of the swing. Mill the bottom back rail and two stiles to size as described earlier to leave crisp edges. Run the bottom edge of the bottom back rail and both stiles through the saw at an 83-degree angle to match the bevel on the seat. Then take the 2x8 top rail and lay out the top arch of the swing by marking the center of the rail, then mark 2-½" down from the top at the center. Tap a small brad nail into the board at this spot, then put two more brad nails into the board at the bottom corner of the board at either end. Then take an eight-foot strip of ¼"-thick wood and bend it across the top nail, attaching the strip to the two lower nails with spring clamps. The arch formed by the strip can then be marked with a pencil, and then a second line (2-½" above the first line), marked. Jigsaw the piece to the outside of these lines, then sand the piece smooth.

To determine the length of the top rail, lay the bottom rail and side stiles flat with the bottom rail between the stiles. Clamp these pieces in place, then lay the top rail across the tops of the stiles, flush to the top outside corner of each stile. With the top rail in place, mark the point where the inside curve of the rail intersects the inside edge of the stiles. Connect the two points and this is the angle to cut on the top edges of the stiles and on the ends of the top rail, to form mitered joints. The back frame will be held together with a double helping of biscuits, but first you need to cut the groove in the top and bottom rails to hold the slats.



With the seat frame assembled, nailing the slats in place was a cinch with a pneumatic finish nailer and stainless steel nails. Note the 7-degree bevel on the rear of the back seat rail.



Holding the arched top rail steady was the most difficult part of routing the top groove for the slats. Remember to make the cut in two passes on each side. In this photo you can see that the rail hasn't been cut for length yet, allowing extra support for the router at the beginning and end of the cut.



With the miters cut on the top rail and back stiles, space the slats and use the top rail to mark the angle and length of each slat, (adding 1").

Running the groove in the bottom rail is fairly simple. Set up a router with a straight bit (or an up-spiral bit) of either 3/8" or 1/2" diameter. Next set up a fence on the router 7/16" from the bit, and set the bit for a 1/2" depth. (The final depth is 1", but take it in two passes.) By running the router on both long edges of the rail, the groove will be centered on the piece. Check the fit of the back slats in the rail (or better, a test piece), then make the groove.

To cut the same groove in the arched top rail, see the photo at left. You will need to adjust the depth of the final cut a bit to compensate for the curve of the arch.

Miter the top rail to length, then check the fit of your slats in the grooves. The spacing between the slats should be about 2-1/4", but double-check your dimensions.

After cutting the double biscuits at the joints, place the slats in the bottom groove and locate the top rail in position on the slats. Mark the height and curve on each slat. Remove the slats, numbering them as you do. Now add 1" in length to the marks on the slats and cut them to their finished length using the band saw. You're now ready to glue up. I used polyurethane glue for all my glued joints. The polyurethane adhesive provides a strong water-resistant bond in even long-grain to short-grain joints. Don't glue the slats in place, however. Place them in the grooves in their approximate positions, then after the frame has dried, use a brad nailer to tack the slats in place with a single brad at top and bottom, from the back. To protect the lower rail from rot from standing water in the groove, cut blocks, (called fillets), the size of the spaces and glue them in place.

You're now ready to glue and bolt the back to the seat. I used four 1/4" threaded bolts with washers to bolt the bottom rail of the back to the back rail of the seat. Hold the bottom edges of each flush, and again use polyurethane glue on this joint.

Next cut the two arms and arm supports from 2x4 material and cut them to shape using the scaled drawings on the next page. You may want to cut the angle on the bottom of the support and on the back end of the arms, then fit them in place and confirm the location and angle of the top end of the supports. Attach the arms to the back with a long deck screw through the back stile. Glue the support to the arm and to the seat with 1/2" dowels between.

The last step is to put the legs on the table, and to notch and fit the support cleats. Start by cutting the leg pieces to the sizes given in the Schedule of Materials. They are two different lengths to allow the table to sit parallel to the ground, even though the swing itself is angled back. Round over the top end of each leg to allow it to swivel without catching, then drill 1/4" clearance holes, 1/2" down and centered on the legs. Drill clearance holes in the table battens 1/2" up from the bottom edge, and 1" in from the inside corners. Attach the legs using 1/4" x 2 1/2" bolts with two washers on either side of the leg and a nylon-lined nut to hold the legs tight, but not immobile.

Check the spacing between the legs (near the bolts) then cut the leg braces to fit, and screw them in place between the legs.

Now head back to the saw and cut the two table support cleats to fit between the inside stringers. Clamp these in place, center the table in place left to right and mark the location of the legs.

Remove the cleats and cut 7/8" x 1" notches on the leg locations. Then use a handsaw to trim the ends of the legs to form tongues to fit into the mortises you've just created in the cleats. Glue the cleats in place, and once dry, the table will drop into place in the cleats, holding the table steady.

After adding 3/8" x 4" eye bolts to the front and rear of the swing seat, the swing is ready to hang. If you've got a porch, find a sturdy joist and get the lemonade. If you happen to be missing a porch, construct a simple A-frame structure to let you swing in style anywhere in your yard.



The back of the arm is simply screwed in place through the back stile, while the support is attached to the arm and seat with dowels and polyurethane glue. Notice the foamy squeeze-out of the glue at the joints.



With the notches cut in the support cleats, the two pieces can be glued in place in the seat frame.



Last, but not least, bolt the table legs in place to the table battens. Note the notches on the ends of the legs which drop into the previously cut notches to stabilize the table.