

134
**EARLY AMERICA
BOOKCASE**



This Early American bookcase is versatile enough to blend with almost any decor. If you eliminate the decorative molding, the bookcase is not only easier to build, but it will also fit in with most modern or traditional furnishings. As shown, the bookcase is 7 feet high, 30 inches wide, and about 12 inches deep, but its design can be varied to suit your needs. The bookcase can also be used as a unit in wall-to-wall bookcases.

If you plan to build wall-to-wall bookcases, omit the molding supports where the sides of two units meet, since the moldings will get sufficient support from the adjoining sides. You can also omit the mitered joints and the side sections of the crown and baseboard moldings.

Construction: Begin the construction of the bookcase by cutting and assembling the shell. Cut the two sides (A), bottom (B), and top (C) of the shell from three 8-foot-long 1 x 12's. The top and bottom pieces fit into dadoes in the sides of the shell. The plywood back (E) is fitted into rabbets in the sides. (Directions are given in Steps 4-8 for cutting dadoes and rabbets with a circular saw. Before you assemble the shell, you must drill holes for the shelf supports at uniform 2-inch intervals. It is very important to space the holes properly, otherwise the shelves will not hang evenly. To avoid problems, use a homemade template as described in Step 9.

After the top, bottom, and sides are assembled, use the actual dimensions of the shell as a guide for cutting the shelves (D), the plywood back (E), the moldings (F-K), and the molding supports (L). Cut the shelves from two 8-foot-long 1 x 12 boards. Make each shelf 3/16 inch shorter than the interior width of the assembled shell and test-fit the first shelf before cutting the other five.

If you do not wish to use the exact moldings shown on the following page, you can substitute other moldings, but be sure to use moldings of the same width as those indicated in the chart, or adjust the measurements accordingly. Cut the shelf molding (F) from two 8-foot lengths. Cut the other molding and molding supports from 7-foot lengths of the appropriate material. Order extra molding to allow for possible errors in mitering. You may want to substitute simple 3-inch baseboard molding for the crown moldings (J and K), as the latter require an extra-deep miter box in order to be cut.

Never apply clamps directly to the surface of wood or they may leave unsightly marks. Always cushion the clamp by placing bits of scrap wood between the clamp and the good wood.

Before applying stain to the finished bookcase, test it on a piece of scrap wood. The longer you leave the stain on the wood before wiping off the excess, the darker the wood will become, so experiment on scrap wood in order to get the shade you prefer on the finished unit.

| Parts list | | | | | | |
|------------|-------------------------|----------|-----------|----------|----------|--------------------|
| Part | Name | Quantity | Thickness | Width | Length | Material |
| A | Side | 2 | 3/4" | 11 1/2" | 82" | 1 x 12 knotty pine |
| B | Bottom | 1 | 3/4" | 11 1/4" | 29" | 1 x 12 knotty pine |
| C | Top | 1 | 3/4" | 11 1/4" | 29" | 1 x 12 knotty pine |
| D | Shelf | 6 | 3/4" | 10 1/8"* | 28 3/8"* | 1 x 12 knotty pine |
| E | Back | 1 | 1/4" | 29 1/4"* | 78 1/2"* | Birch plywood |
| F | Shelf molding | 6 | — | 7/8" | 26 7/8"* | Pine |
| G | Front baseboard molding | 1 | — | 3 1/2" | 30 1/2"* | Pine |
| H | Side baseboard molding | 2 | — | 3 1/2" | 11 1/2"* | Pine |
| I | Fluted molding | 2 | — | 1 1/2" | 77"* | Pine |
| J | Front crown molding | 1 | — | 3" | 30 1/2"* | Pine |
| K | Side crown molding | 2 | — | 3" | 11 1/2"* | Pine |
| L | Molding support | 2 | 3/4" | 3/4" | 77"* | 1 x 1 pine |

*Measurements are approximate. Parts D-L should be measured against the assembled bookcase shell before cutting.

Tools and materials: Circular saw with adjustable blade depth or table saw or radial arm saw. Electric drill with set of twist bits. Backsaw, deep miter box. Orbital sander (optional). Combination square, framing square, steel tape rule, pencil. Four 5" C-clamps. Hammer, nail set. Paintbrush. Wood putty. Nos. 80, 100, 150, and 220

sandpaper, 0000 steel wool, oil stain, satin finish polyurethane, turpentine, paste wax, carpenter's glue. Tack cloth, soft cloths. Wood and molding (see above) and 3" x 82" scrap of 1/4" pegboard. Box of 3/4" 19-gauge wire brads. 3d, 4d, and 6d finishing nails, 3d common nails. Twenty-four metal shelf rests.



Decorative moldings

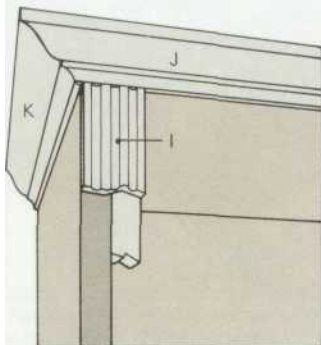

The fluted moldings (I) on the front edges of the bookcase meet the flared crown moldings (J and K) at the top corners.

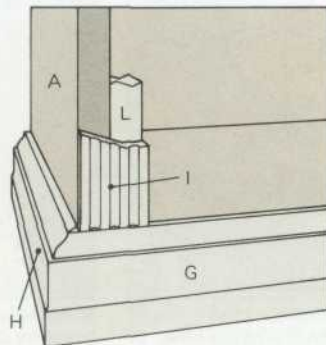

The fluted moldings (I) also meet baseboard moldings (G and H) and are attached to bookcase sides (A) and supports (L).

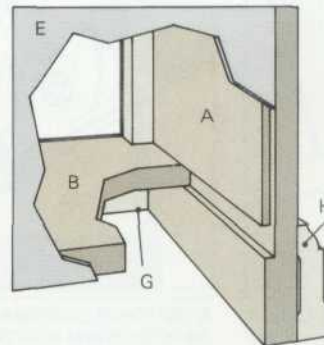

The bookcase back (E) fits into the rabbets cut into bookcase sides (A); it is flush with lower edge of bookcase bottom (B).

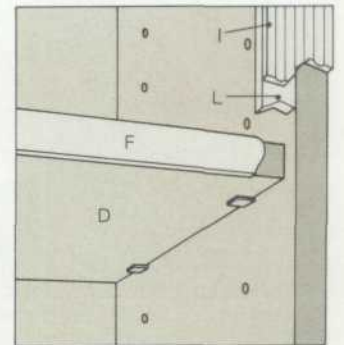

Each shelf (D) is faced with 7/8-in. pine molding (F) that fits with a small clearance against supports (L) at each side.

Early American bookcase

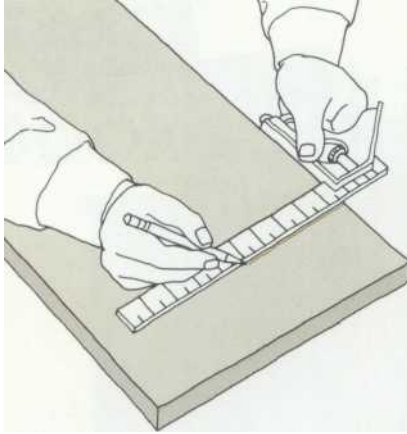

1. Cut 1/4 in from width of lumber for bookcase bottom (B) and top (C) using a circular saw with a rip blade and a guide (see Step 2). Use a combination square and pencil to draw a squared-off line for first crosscut near ends of this lumber and lumber for sides (A).

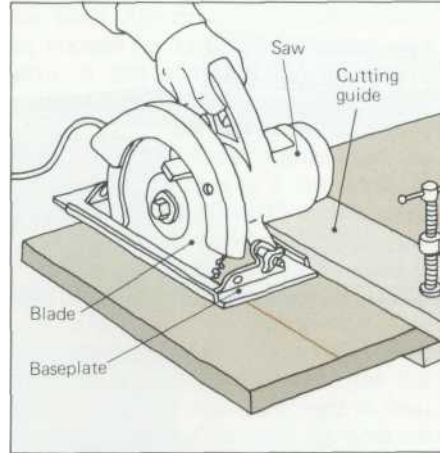

2. Use a circular saw with a crosscut blade to cut along the line. Clamp a straight strip of wood to the piece being sawed to act as a cutting guide; the distance between guide and cutting line must equal the distance between the saw's baseplate and blade.

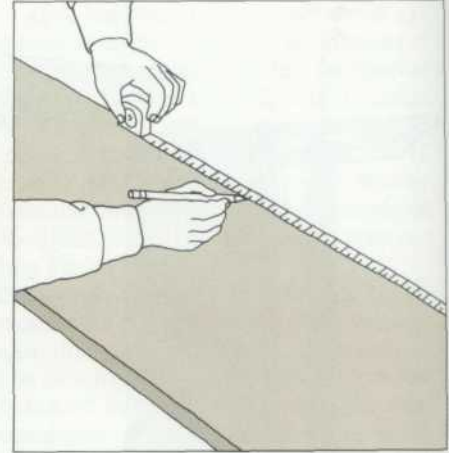

3. Following the dimensions given in the chart, measure the correct distance from the squared end of the board to the next cut, then use combination square to draw a line for the next crosscut and cut along it. Label each piece as you cut it for easy identification.

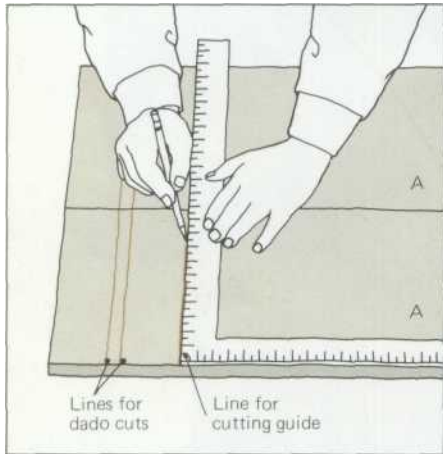

4. Lay the sides (A) side by side. Draw cutting lines for the bottom dadoes across both sides 2 3/4 in. and 3 1/2 in. from one end. Set the blade of the circular saw to cut to a depth of 1/4 in. and cut dadoes between the pairs of cutting lines into one side at a time (Steps 5 and 6).

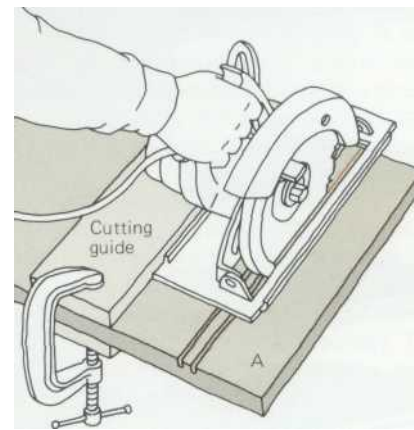

5. Clamp a scrap-wood cutting guide to each side (A), in turn, so that when the baseplate of the saw butts against the guide, the saw blade is just inside one rule. Cut along the rule. Move the guide and cut along the other rule. Make several parallel cuts between these two

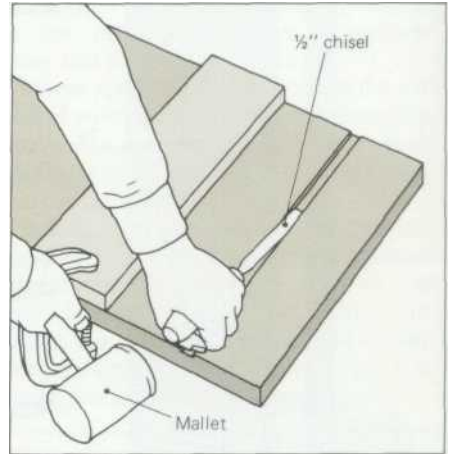

6. Remove the waste wood with the saw or with a chisel and mallet. Measure and mark off cutting lines for the top dadoes 3/4 in. and 1 1/2 in. from the opposite ends of the side pieces. Cut 1/4-in.-deep dadoes between these pairs of cutting lines as you did for bottom dadoes.

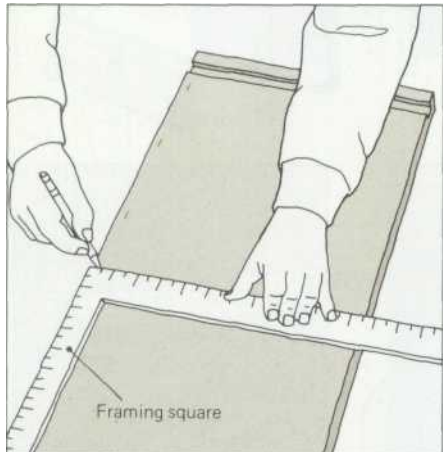

7. Use a framing square and a pencil to mark off points along the inside of the two bookcase sides (A) 1/4 in. from the back edges. Draw rules through these points from top dado to bottom dado to serve as cutting lines for the rabbets the plywood back (E) will fit into.

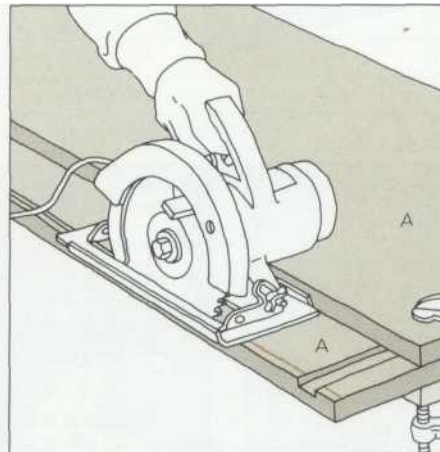

8. Set the circular saw blade for a 3/8-in.-deep cut. Clamp one side (A) on top of the other to serve as a cutting guide and cut along the rule. Reposition the cutting guide and cut the remaining wood from the edge. Repeat this process to cut the rabbet on the other side.

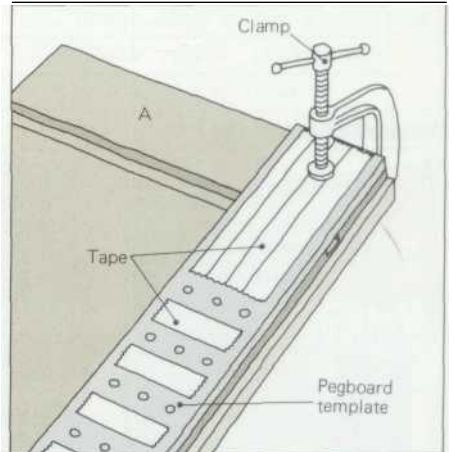

9. Make a template for drilling shelf-support holes by cutting a scrap of 1/4-in. pegboard 3 in. wide by 82 in. long with a row of holes at its exact center. Clamp template to the front inside edge of one bookcase side (A). Block alternate rows of holes with tape

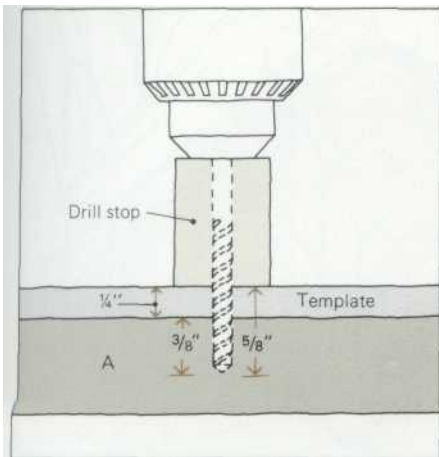

10. Make a drill stop by cutting a piece of scrap wood so that when the drill goes through it, 5/8 in. of the drill protrudes, excluding its point. This will allow the drill to pass through the Win. template and bore exactly 3/8 in. into the side (A).

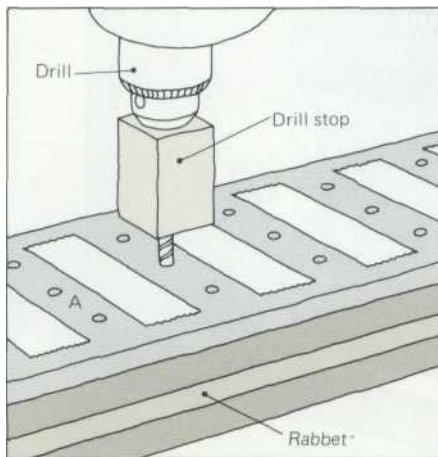

11. Drill into the center holes of the untaped rows in the template. Slide the template to the back edge of the side (A) and drill into the same holes. Move the template, with the same side facing up and its ends pointing in the same direction, to the second side.

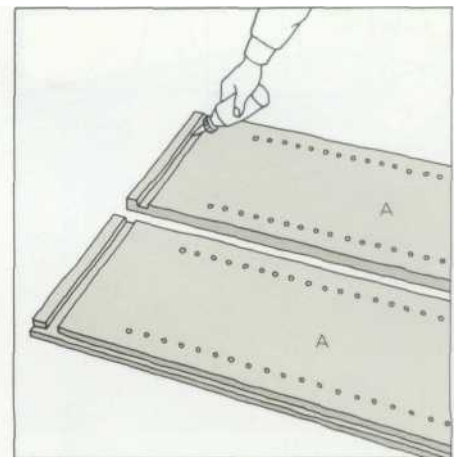

12. Bore shelf-support holes into the second side (A) as you did into the first. Sand the inner portions of the sides, bottom (B), and top (C) with Nos. 80, 100, and then 150 sandpaper. Lay out the sides, inner portions up, and apply glue to the dados.

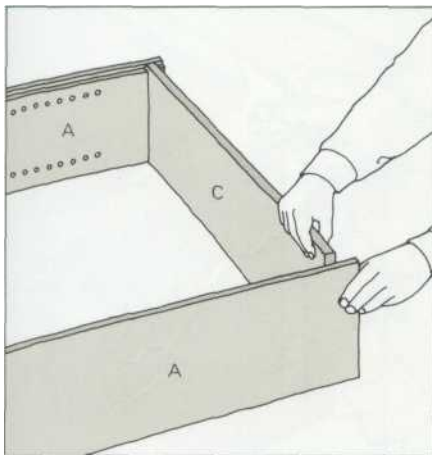

13. Be sure to apply enough glue to completely cover the bottoms and sides of the dados, then fit the bookcase bottom (B) and top (C) into the dados of one side (A) and then the other. (Position the bookcase shell with the rabbets facing up.)

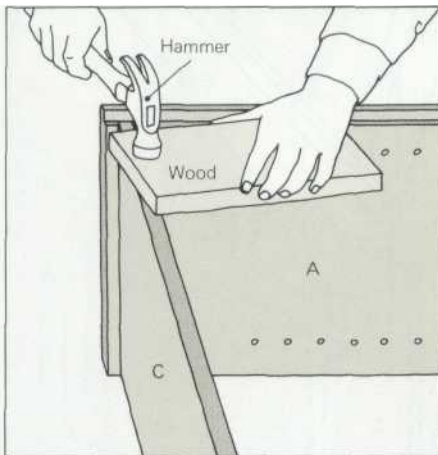

14. Before glue dries, wipe off all excess with a damp cloth. Align the top and bottom of the bookcase with the back edges of the dados by tapping them gently near the joints with a hammer that is buffered with a piece of wood, as shown, or with a mallet.

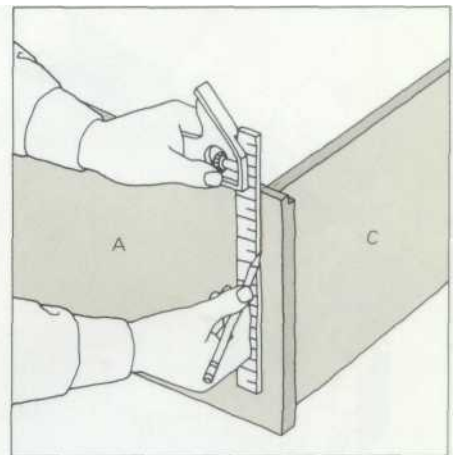

15. Mark the center of the top and bottom dado joints on the outside of the bookcase sides. Use a combination square and pencil to extend each mark along each side, forming guide lines that can be used to guide the proper placement of the reinforcing nails.

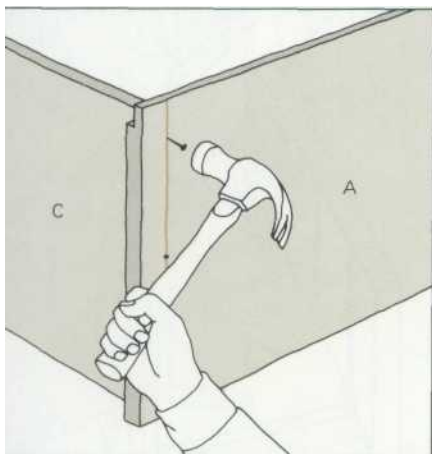

16. Nail the bookcase sides (A) to the bookcase bottom (B) and top (C) with 6d finishing nails. Use about three nails for each joint and drive them in along the guide lines that were drawn in Step 15. Use a nail set and hammer to set all the nails.

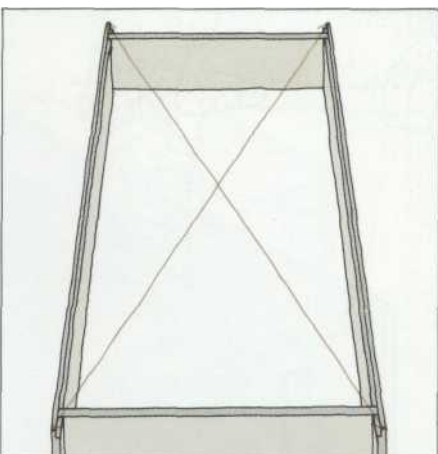

17. Check the bookcase shell for squareness by measuring its front from the upper left-hand corner to the lower right and the upper right to the lower left. If the two measurements are not identical, the bookcase is not square. Adjust the squareness before the glue dries.

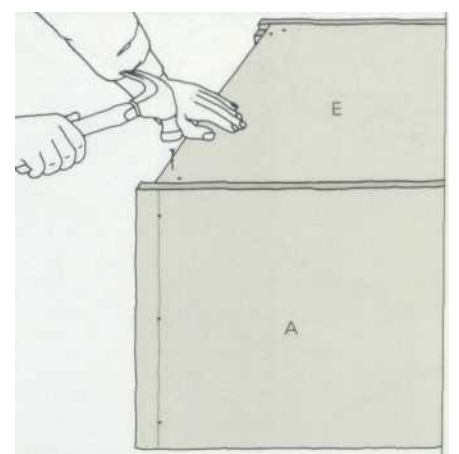

18. Get exact measurements for the bookcase back (E) from the shell, cut the plywood accordingly, and sand one side with Nos. 80, 100, and then 150 paper. Position back over shell, sanded side down, and nail each of its corners to shell with two 3d nails.

Early American bookcase

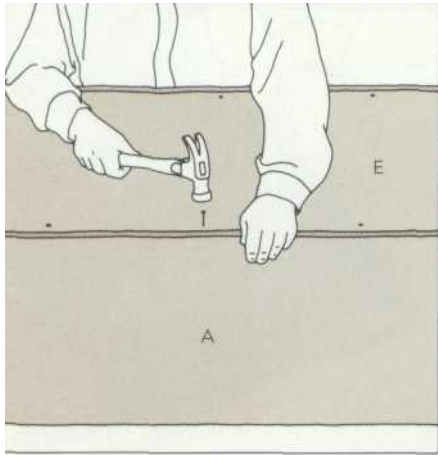

19. Drive more nails through the back into the sides, bottom, and top of the bookcase. Use one nail about every 8 in. If the bookcase sides bow out, pull them inward as you drive the nails home along the center portions of the sides. Do not set the nails

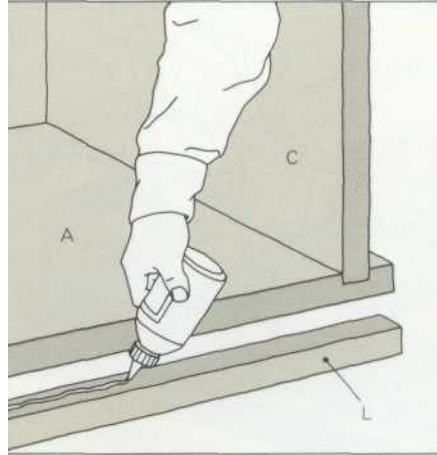

20. Measure and cut the molding supports (L), and then glue and nail them to the inside front edges of the bookcase sides (A). These will support the thin fluted moldings that run down the front of the bookcase. Use 3d finishing nails and set them.

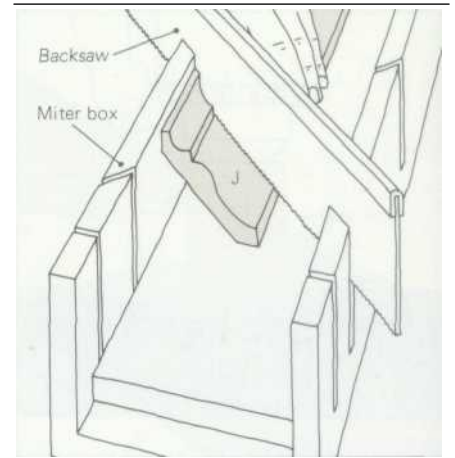

21. Clamp a length of crown molding (J) into a deep miter box with the top of the molding facing down. Angle the molding, as shown, with its bottom flush against the side of the box and its top against the floor of the box. Make a 45° miter cut with a backsaw

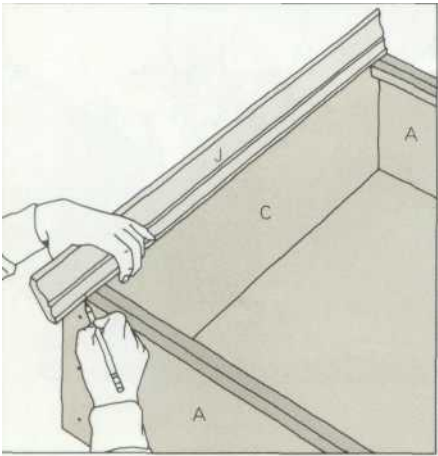

22. Place the cut piece of crown molding against the top of the bookcase shell, with the shorter cut corner of the molding against one front top corner of the shell. Mark the molding for the second miter cut where it meets the other side of the bookcase shell.

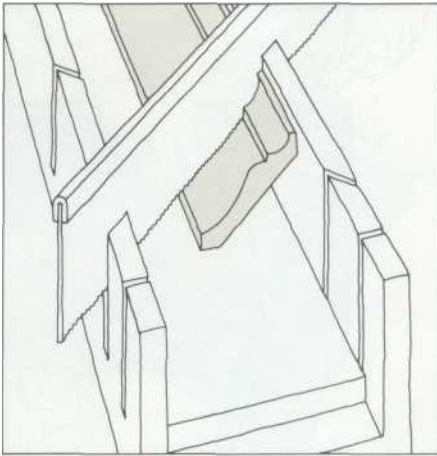

23. Return the molding to the miter box, but this time place it against the opposite side of the box with the cutting mark against a saw slot that runs in the opposite direction from the first. Hold the molding firmly in place and make the second miter cut.

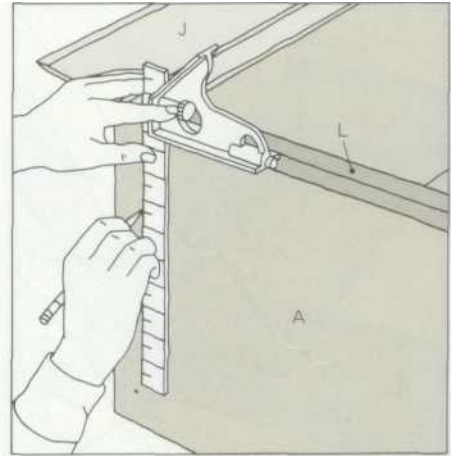

24. Glue and nail the mitered molding to the top of the bookcase with 4d finishing nails, but do not drive the nails all the way in. Use a combination square to draw rules on the sides of the bookcase to extend the bottom line of the front molding (J) along the sides (A)

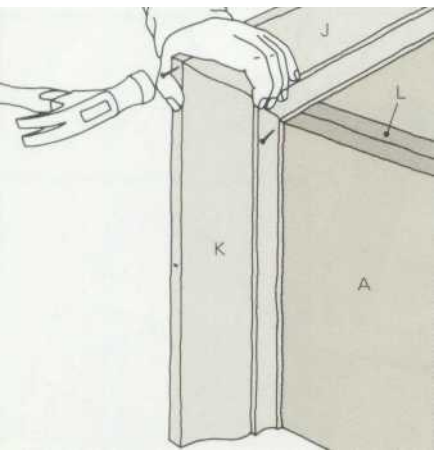

25. Measure the side crown moldings (K) against the bookcase and cut miters in one side. Cut the opposite side flush with the back of the bookcase. Rub glue into the mitered edges and position the side moldings on the bookcase and nail them on.



26. Align the mitered joints and carefully wipe off all the excess glue with a well-dampened cloth. (The stain will not penetrate the glue, so it is important to remove all the excess.) Drive all the nails home and use a nail set and hammer to set them.

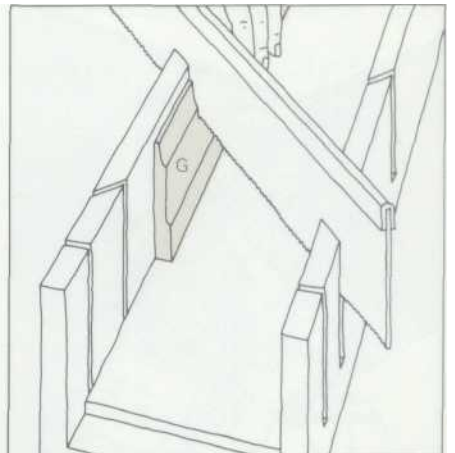

27. Measure, mark, cut, and attach the front and side baseboard moldings (G and H) as you did the crown moldings in Steps 21 -26, but when cutting the miters in the baseboard moldings, hold each molding flush against the side of the miter box, as shown here.

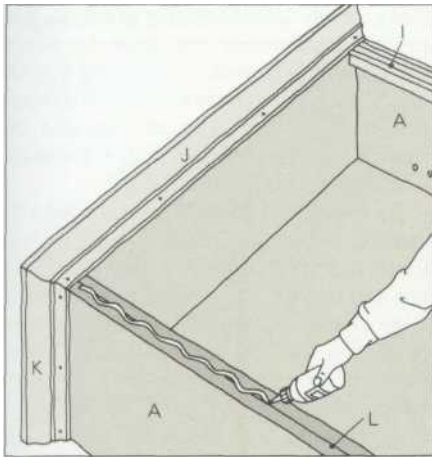

28. Measure the fluted moldings (I) against the sides of the bookcase and cut them. Glue them to the sides and molding supports, and wipe off the excess glue with a damp cloth. Nail the moldings down with 3/4-in. 19-gauge wire brads. Set the brads.

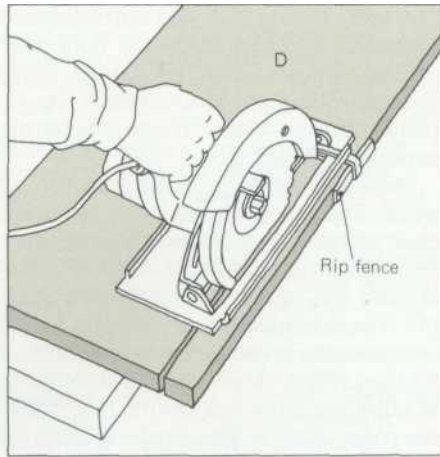

29. In order to fit properly, the shelves (D) must be narrower than the boards they are cut from. Use a circular saw with a rip blade and rip fence to cut the boards to a width of 10 1/8 in. Set fence for amount of wood to be removed and cut along length of each shelf.

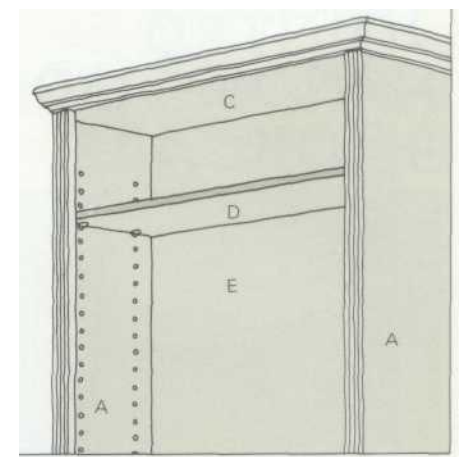

30. Measure the inside width of the bookcase and cut the first shelf 3/16 in. shorter than the measurement you get. Test-fit shelf by placing it into position. It should fit in easily without forcing. Adjust your measurements, if necessary, and cut the other five shelves.

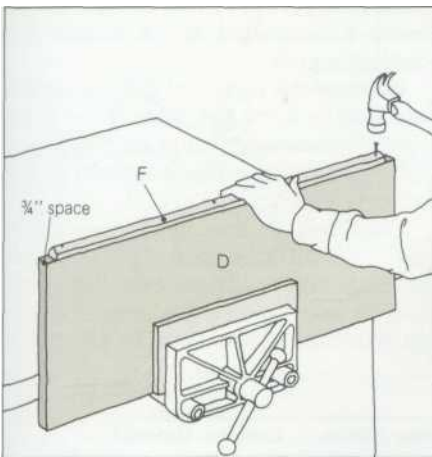

31. Clamp each shelf to the workbench, in turn, with the front edge up. Measure the shelf molding (F) against the shelf, leaving 3/4 in. on each side. Cut the molding, and glue and nail it to the shelf with 4d finishing nails. Set the nails with a nail set.

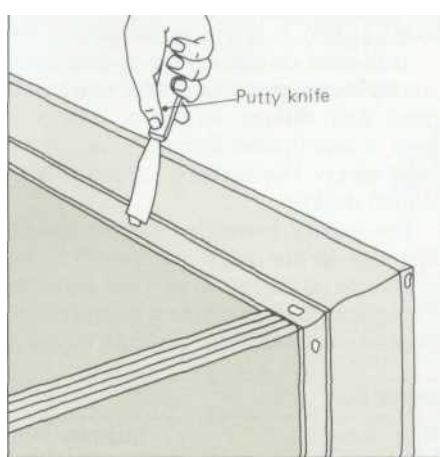

32. Fill all the holes left by these nails with putty. Use your finger or a small putty knife to work the putty firmly into the holes. Leave the putty a little higher than the surface of the wood; it will shrink as it dries, and if it is still too high, you can sand it down.

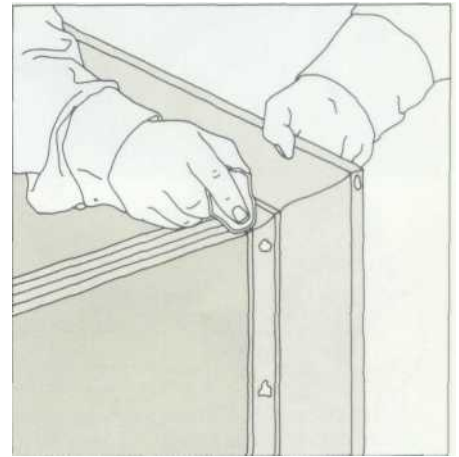

33. When the putty is dry, sand the bookcase and shelves with Nos. 80, 100, and then 150 sandpaper. When sanding moldings, use No. 100, then No. 150 paper and bend it around your finger. When sanding near mitered joints, sand away from joints along molding.

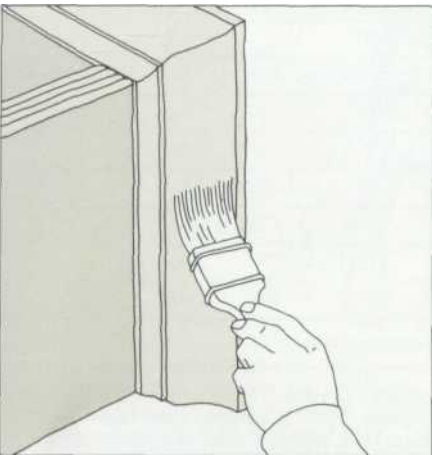

34. Brush the sanded bookcase and shelves with a tack cloth to remove the sawdust created by the sanding. Use a small brush to paint on the stain. Let the stain sit for 10 min., and then wipe off the excess with a clean, soft cloth. Let the stain dry for 24 hr.

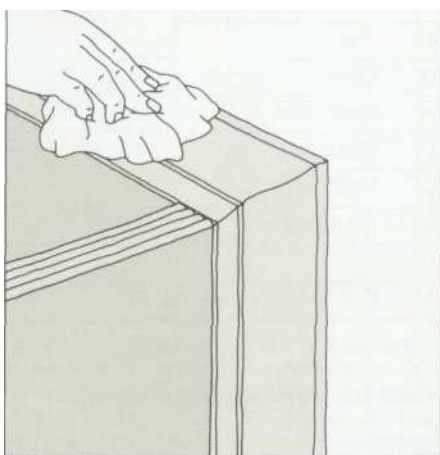

35. So that the first coat of polyurethane penetrates more deeply, brush on a coat of sealer made up of 70% satin polyurethane and 30% turpentine. Wipe off the excess after 10 min. After 4 hr. brush on a coat of full-strength polyurethane. Let it dry for 24 hr.

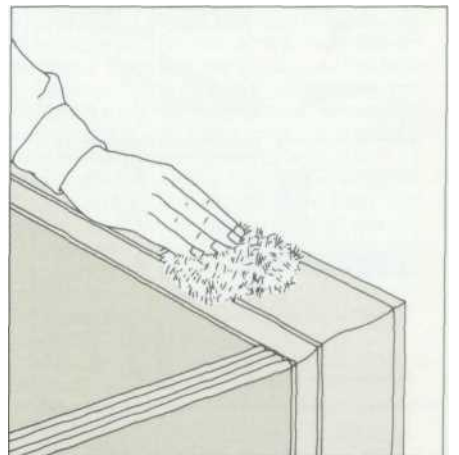

36. Sand all surfaces lightly with No. 220 sandpaper, then remove the sawdust with a tack cloth. Brush on another coat of full-strength polyurethane and let it dry for 24 hr. Apply paste wax with 0000 steel wool using medium pressure. Buff with a soft cloth.