



Project 19777EZ: Toy Wagon

This sturdy wagon provides room for a sizable supply of blocks, stuffed animals, books, or any other valued possession that a toddler might enjoy hauling around the house. Except for the birch dowel pins and the plywood bottom, all parts are made from maple, a wood that's both hard and durable.

Toy Wagon Materials List

Part	Description	Size	No. Req'd
A	Side	3/4" x 4" x 16"	2
B	End	3/4" x 4" x 9-1/4"	2
C	Bottom	1/4" x 9-1/4" x 15-1/4"	1
D	Back Axle	1-1/2" x 2-3/4" x 7-1/2"	1
E	Front Axle	1-1/2" x 2" x 7-1/2"	1
F	Spacer	3" dia. x 3/4" thick	1
G	Yoke	3/4" x 4" x 5-3/4"	2
H	Handle Shaft	3/4" x 1-3/4" x 22-1/2"	1
I	Handle	3/4" x 3/4" x 7"	1
J	Axle Pin	1/2" dia. x 2" long	4
K	Wheel	3-1/2" dia. x 3/4" thick	4
L	Cap	1" dia. x 3/8" thick	4

Toy Wagon Complete Schematic

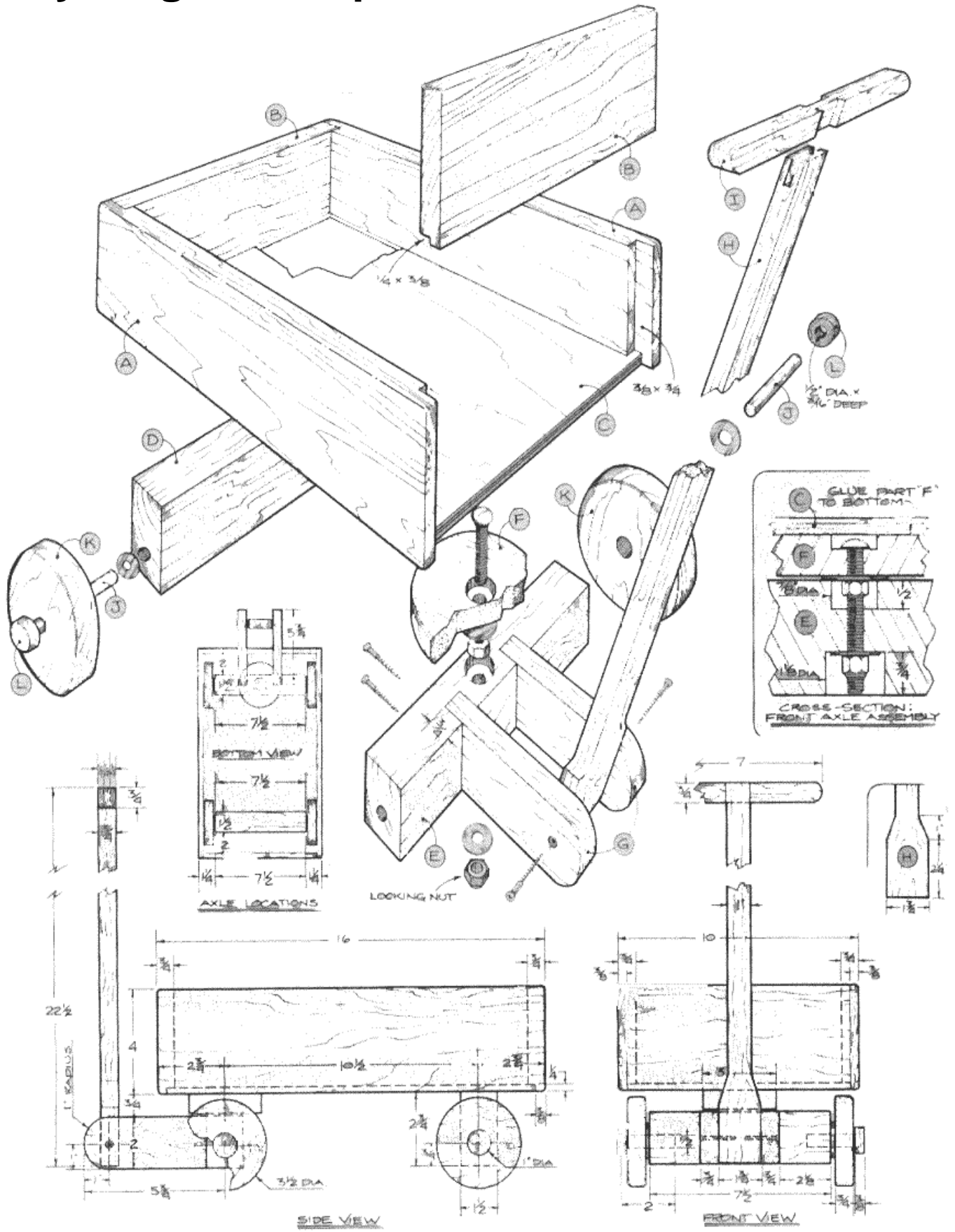

Toy Wagon Step-by-Step Instructions

1. Cut 3/4" thick stock to a width of 4" and a length of about 54" to make the sides (A) and ends (B). **NOTE: The length dimension allows for some extra stock.**
2. Use the dado cutter to cut a 1/4" by 3/8" rabbet all along one edge.
3. Use the regular saw blade to crosscut the stock into four pieces: two pieces 16" long (for the sides) and two pieces 9-1/4" long (for the ends).
4. Use the dado head again to cut the 3/8" by 3/4" rabbet on each end of the sides.
5. Cut the bottom (C) from 1/4" thick birch plywood, making sure the cuts are square.
6. Give each part a thorough sanding.
7. Apply glue to all mating surfaces to assemble the sides, ends, and bottom.
8. Use bar or pipe clamps to apply pressure.
9. Check for squareness.
10. Set aside to dry overnight.
11. Select 1-1/2" thick stock to make the back axle (D) and the front axle (E).
12. Rip the back axle to a width of 2-3/4".
13. Rip the front axle to a width of 2".
14. Cut both axles to a length of 7-1/2".
15. Bore a 1/2" diameter hole at a point 3/4" from the bottom edge of each axle (see side view) to a depth of 1"
16. Use a dado cutter to cut the two 3/4" by 3/4" dados at a point 2-1/8" from each end (see front view) of the front axle.
17. Bore a 3/8" hole at the centerpoint of the top edge (see cross section, front axle assembly) through the front axle.
18. Counterbore the hole on the top edge to 7/8" diameter x 1/2" deep.
19. Counterbore the hole on the bottom edge to 1-1/8" diameter x 3/4" deep.
20. Cut 3/4" stock to 3/12" square to make the spacer.
21. Use a compass to scribe a 3" diameter circle.
22. Use a band or saber saw and, staying just outside the marked line, cut the circle out.
23. Sand the rough edge exactly to the line.
24. Bore a 3/8" diameter hole at the centerpoint.
25. Counterbore the hole to 7/8" diameter by 1/4" deep.
26. Assemble a 3/8" diameter by 2-1/2" long carriage bolt to the spacer (see exploded view).
27. Add a 1-1/4" diameter washer and nut to hold the bolt in place.
28. Make sure the grain direction of the spacer runs parallel to the grain direction of the bottom.

29. Glue the spacer to the underside of the bottom.
 30. Clamp firmly to insure a good glue bond.
 31. Select 3/4" stock from which to cut the two yokes (G).
 32. Cut the yokes to to length and width.
 33. Round over the front end with a band or saber saw.
 34. Sand smooth.
 35. Glue and clamp the front axle as shown.
 36. Allow the glue to dry.
 37. Bore pilot holes and assemble two 1-3/4" by #8 flathead wood screws in the end of each yoke.
 38. Make and assemble the handle shaft (H) and the handle (I) as shown.
 39. Use a pair of 1-1/4" x #8 flathead wood screws to join the base of the handle shaft to the yoke.
 40. Tighten the screws completely, then back off about one turn to allow the handle shaft to pivot freely.
 41. Glue and clamp the back axle to the underside of the bottom.
 42. Allow the glue to dry.
 43. Use a 1" diameter washer and a locking nut to assemble the front axle to the carriage bolt.
 44. Cut 1/2" diameter birch dowel stock into four pieces, each 2" long to make the axle pin (J).
 45. Glue into the axle holes as shown.
 46. Lathe-turn the four wheels (K) and caps (L).
 47. Bore a 1/2" diameter x 3/16" deep hole in each wheel.
 48. Glue the caps in place, avoiding any glue squeeze-out that would cause the cap to stick to the wheel.
 49. Round over all sharp edges.
 50. Final sand.
 51. Leave unfinished.
-