



Wow! I Made It.com



Day Bed

How do you combine an office and a guest bedroom? Build this good-looking daybed. During office hours it provides ample seating, and when an overnight guest arrives, it accommodates them in style. Even spare sheets and blankets are kept handy: the front panels are hinged to provide under-the-bed storage.

Materials

- 12 linear feet of 1 x 2 pine
- 110 linear feet of 1 x 4 pine
- 6 linear feet of 1 x 10 pine
- 86 linear feet of 2 x 4 pine
- One piece of 3/4" plywood, 35" x 74"

Hardware

- 200 1-1/4" (3d) finishing nails
- 24 2" (6d) finishing nails
- 30 1-1/2" wood screws
- 63 2" wood screws
- 102 2-1/2" wood screws
- 4 cabinet hinges
- 4 magnetic catches

Special Tools and Techniques

- Bar clamps or pipe clamps
- Miters
- Dadoes
- Hand plane
- Router with 3/8" round-over cutter

Cutting List

Code	Description	Qty	Materials	Dimensions
A	Long Frame	4	2 x 4 pine	74" long
B	Short Frame	4	2 x 4 pine	35" long
C	Frame Support	6	2 x 4 pine	28" long
D	Frame Connector	10	2 x 4 pins	11-1/4" long
E	Platform	1	3/4" plywood	35" x 74"
F	Headboard Top/Bottom	2	2 x 4 pine	35" long
G	Headboard Slat	10	1 x 4 pine	35" long
H	Headboard Side	1	1 x 2 pine	41" long
I	Footboard Top/Bottom	2	2 x 4 pine	35" long
J	Footboard Slat	10	1 x 4 pine	9-1/4" long
K	Footboard Side	2	1 x 2 pine	15-1/4" long
L	Bottom Back	1	2 x 4 pine	75-1/2" long
M	Long Top Back	1	2 x 4 pine	40" long
N	Short Top Back	1	2 x 4 pine	39" long
O	Back Connector	1	2 x 4 pine	15-1/2" long

P	Long Back Slat	11	1 x 4 pine	35" long
Q	Short Back Slat	11	1 x 4 pine	23" long
R	Long Back Side	1	1 x 2 pine	41" long
S	Short Back Side	1	1 x 2 pine	29" long
T	Horizontal Trim	2	1 x 4 pine	74" long
U	Vertical Trim	3	1 x 4 pine	8-1/4" long
V	Storage Fronts	2	1 x 10 pine	33-3/4" long

Making the Base Structure

1. Cut four long frames (A) from 2 x 4 pine, each measuring 74 inches long.
2. Miter the ends of each of the four long frames (A) at opposing 45-degree angles, as shown in *Figure 1*.

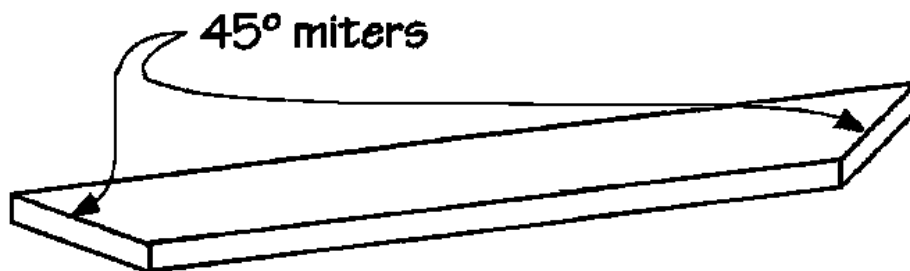
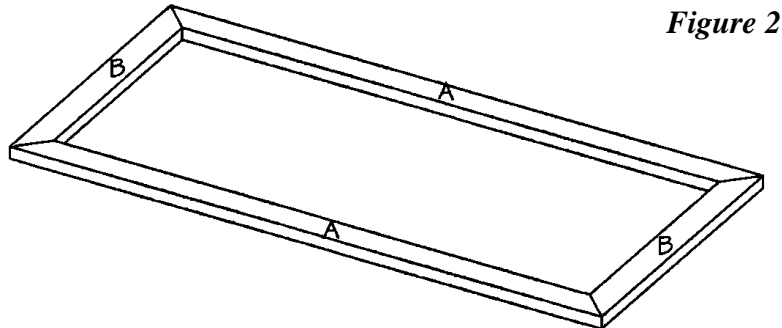

Figure 1

3. Cut four short frames (B) from 2 x 4 pine, each measuring 35 inches long.
4. Miter the ends of each of the four short frames (B) at opposing 45-degree angles, as shown in *Figure 1*.
5. Place two short frames (B) on a level surface, parallel to each other and 67 inches apart.
6. Fit two long frames (A) between the two short frames (B) to form a rectangle measuring 35 x 74 inches, as shown in *Figure 2*. Apply glue to the mitered surfaces, and fasten each joint with two 2 1/2-inch screws driven from the outside edge across the miter joint, one on each side.
7. Repeat Step 6 to construct a second 35 x 67-inch rectangular frame using the remaining two long frames (A) and two short frames (B).
8. Cut six frame supports (C) from 2 x 4 pine, each measuring 28 inches long.

9. Place three frame supports (C), evenly spaced, inside one rectangular frame, as shown in *Figure 3*. Toenail the three frame supports (C) in place, using two 2" (6d) finishing nails on each joint.



10. Repeat Step 10 to add the remaining three frame supports (C) to the other rectangular frame.
11. Cut ten frame connectors (D) from 2 x 4 pine, each measuring 11-1/4 inches long.

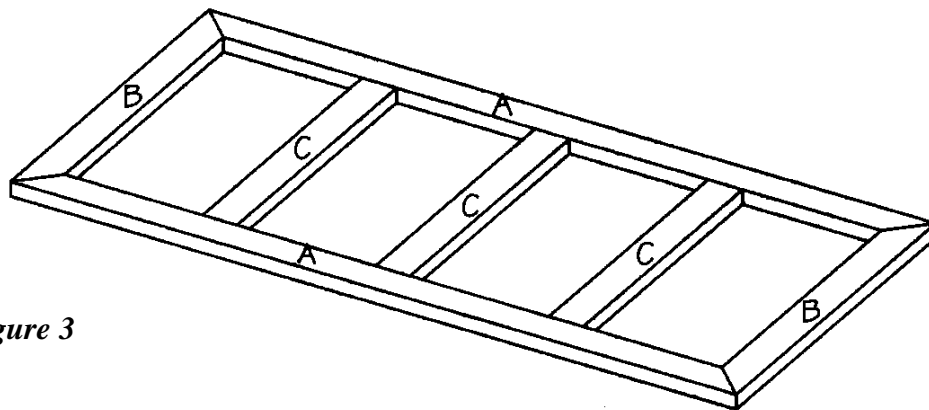

12. This next step will require a helping hand from an interested bystander. Place one rectangular frame on a level surface. Place each of the ten frame connectors (C) on top of the frame, as shown in *Figure 4*. Note that each corner of the frame has two connectors (D) and each long side of the frame has a frame connector (D) in the middle. Each of the frame connectors (D) must be flush with the outer edge of the rectangular frame. Then place the second frame on top of the ten frame connectors (D). Measure to make sure that the frame connectors (D) are correctly positioned on the second frame. Have your assistant steady the assembly while you screw through the second rectangular frame into each of the ten frame connectors (D). Use two 2-1/2- inch screws on each joint.
13. Where two frame connectors (D) meet in each of the four corners, screw through the overlapping frame connector (D) into the meeting edge of the other frame connector (D). Use

three 2-1/2-inch screws on each joint.

Figure 4

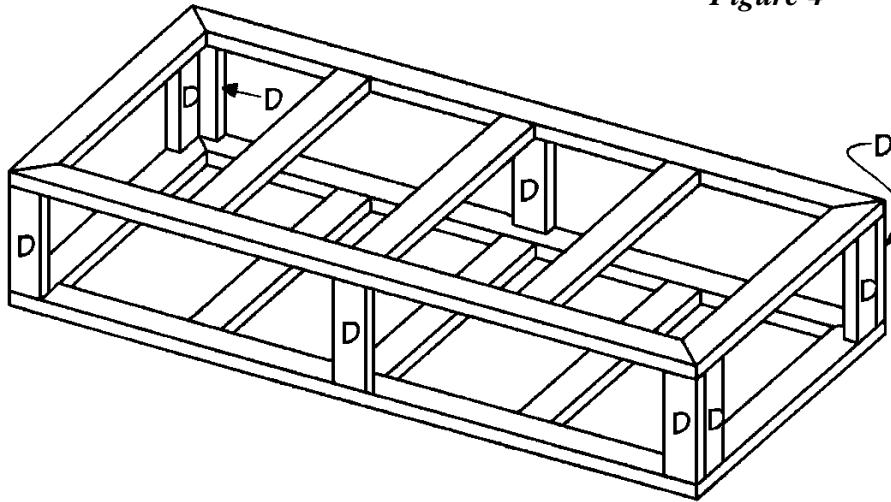

14. Turn the entire assembly upside down, replace the first rectangular frame on the top, measure to check for proper placement, and again screw through the rectangular frame into the frame connectors (D).
15. Cut one platform (E) from 3/4-inch plywood, measuring 35 x 74 inches.
16. Place the platform (E) over the assembly, as shown in *Figure 5*. Apply glue and screw through the platform (D) into the long frame (A), short frame (B), and each of the three frame supports (E). Use 2-inch screws spaced about every five inches.

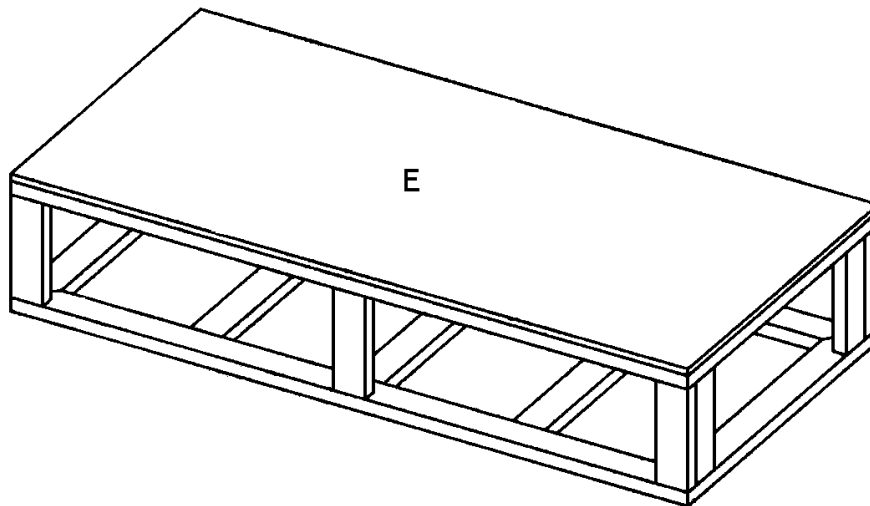

Figure 5

Making the Headboard

1. Cut two headboard top/bottoms (F) from 2 x 4 pine, each measuring 35 inches long.
2. Cut a 3/4-inch-wide dado 1/2-inch deep down the length of one edge of each of the headboard top/bottoms (F), as shown in *Figure 6*.

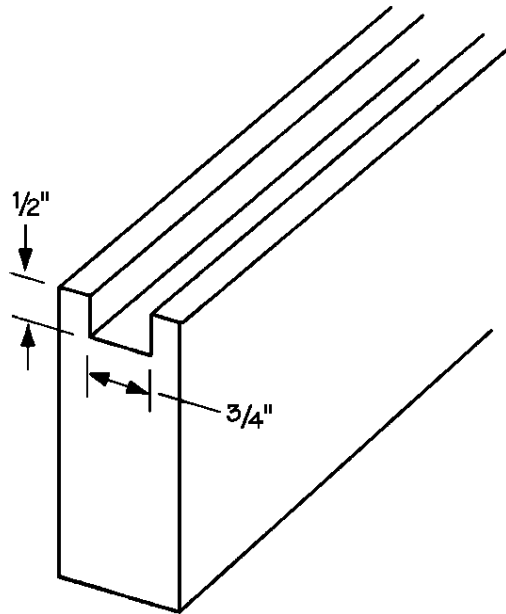

Figure 6

3. Cut ten headboard slats (G) from 1 x 4 pine, each measuring 35 inches long.
4. Working on a level surface, place the two headboard top/bottoms (F) parallel to each other, with the dados to the inside, as shown in *Figure 7*. Fit the ends of the ten headboard slats (G) into the dados in the headboard top/bottoms (F). When the headboard slats are properly fitted, the distance between the two headboard top/bottoms (F) should measure 34 inches. When the positions are perfect, the overall measurement of the headboard assembly should be 41 inches high and 35 inches long. Secure the headboard slats (G) by nailing through the back of the dadoed edge of the headboard top/bottoms (F) into the ends of the headboard slats (G) using two 1-1/4-inch (3d) finishing nails on each joint.
5. Cut one headboard side (H) from 1 x 2 pine measuring 41 inches long.
6. Apply glue to the edge of the end slat and attach the headboard side (H) to one side of the headboard assembly, as shown in *Figure 8*. Nail through the headboard side (H) into the ends of the headboard top/bottoms (F) and into the headboard slat (G). Use 1-1/4-inch (3d) finishing nails spaced every five inches.
7. Attach the headboard to the head of the bed frame, as shown in *Figure 9*. Note that the headboard assembly extends 3/4-inch past the frame assembly at the front. To make the daybed

portable in case of a move, do not use glue. Screw through the bottom of the assembly into the bottom base frame. Use 2-1/2-inch screws spaced about every six inches. There will be a 3/8-inch gap between the headboard slats (G) and the edge of the platform (E).

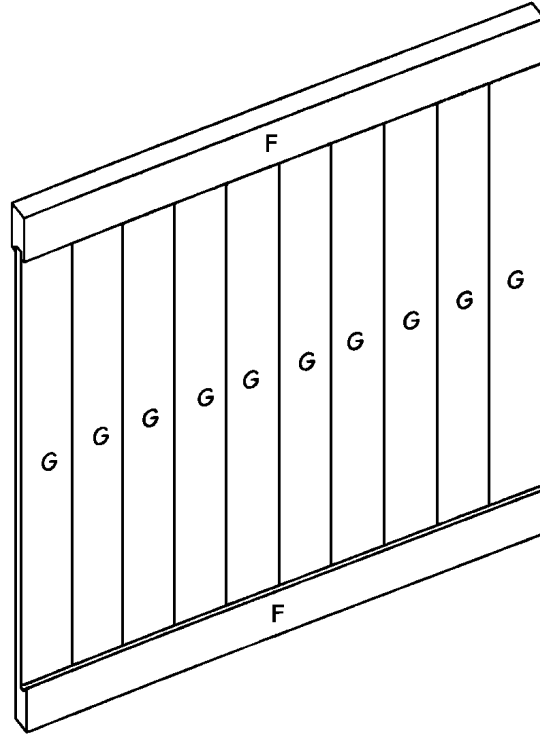

Figure 7

Making the Footboard

1. Cut two footboard top/bottoms (G) from 2 x 4 pine, each measuring 35 inches long.
2. Cut a 3/4-inch-wide dado 1/2-inch deep down the length of one edge of each of the footboard top/bottoms (I), as shown in *Figure 6*.
3. Cut ten footboard slats (J) from 1 x 4 pine, each measuring 9-1/4 inches long.
4. Working on a level surface, place the two footboard top/bottoms (I) parallel to each other with the dados to the inside, as shown in *Figure 7*. Fit the ends of the ten footboard slats (J) into the dados in the footboard top/bottoms (I). When the footboard slats are properly fitted, the distance between the two footboard top/bottoms should measure 8-1/2 inches. When the positions are perfect, the overall measurement of the footboard assembly should be 15-1/4 inches high and 35 inches long. Secure the footboard slats (J) by nailing through the dadoed edge of the footboard top/bottoms (I) into the ends of the footboard slats (I) using two 1-1/4 inch (3d) finishing nails on each joint.

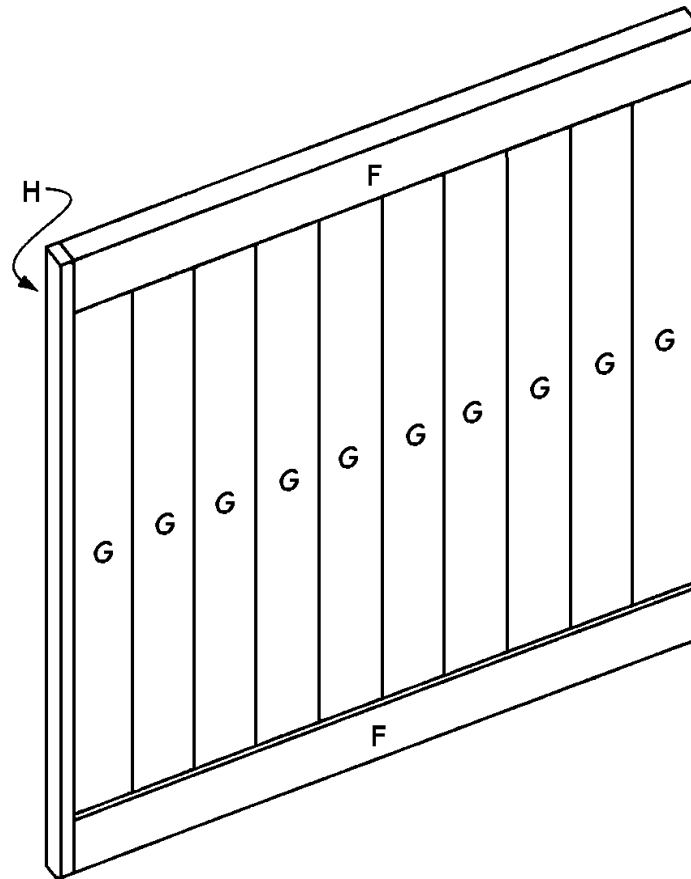

Figure 8

5. Cut one footboard side (K) from 1 x 2 pine measuring 15-1/4 inches long.
6. Attach the footboard side (K) to one side of the footboard assembly, in the same manner as shown in *Figure 8*. Nail through the footboard side (K) into the ends of the footboard top/bottoms (I) and into the footboard slats (J). Use 1-1/4-inch (3d) finishing nails spaced every five inches.
7. Attach the footboard assembly to the foot of the bed frame, as shown in *Figure 10*. Note that the footboard assembly extends 3/4 inch past the frame assembly at the front and 1/4 inch above the platform (E). Apply glue to the meeting surfaces and screw through the bottom of the footboard assembly into the bottom base frame. Also screw through the top of the footboard assembly into the top of the base frame. Use 2-1/2-inch screws spaced about every six inches.

Making the Back

1. Cut one bottom back (L) from 2 x 4 pine measuring 75-1/2 inches long.

- Cut one upper top back (M) from 2 x 4 pine, measuring 40 inches long.

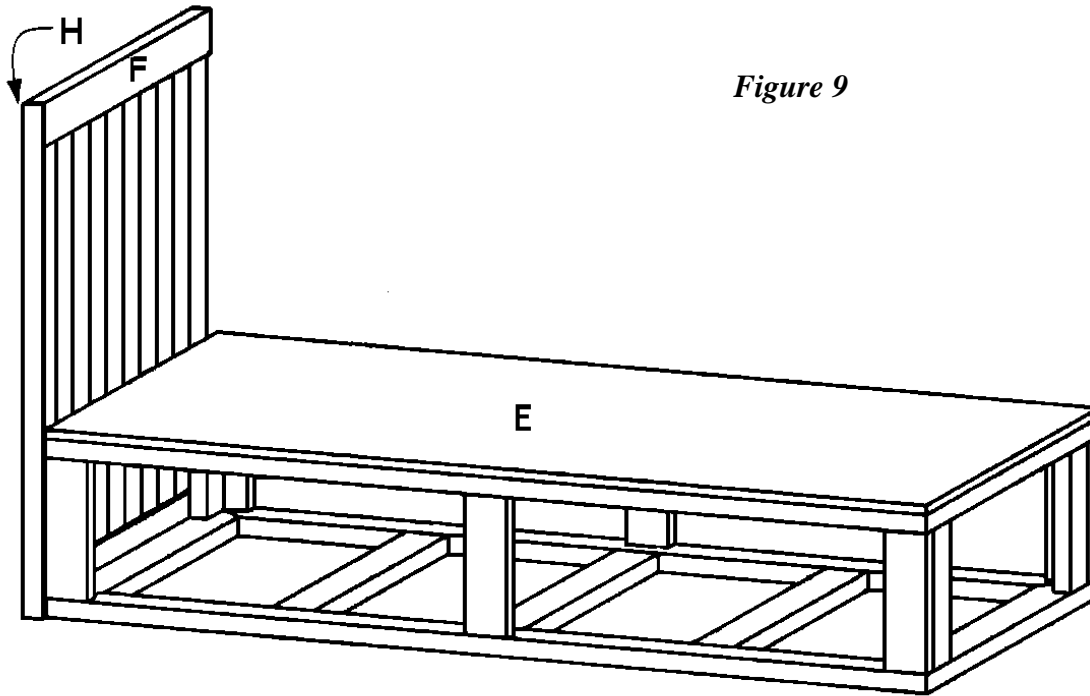

Figure 9

- Cut one lower top back (N) from 2 x 4 pine, measuring 39 inches long.
- Cut one back connector (O) from 2 x 4 pine, measuring 15-1/2 inches long.
- Cut a 3/4-inch-wide dado 1/2-inch deep down the length of one edge of the bottom back (L), the upper top back (M), the lower top back (N), and the back connector (O), as shown in *Figure 6*.
- Cut eleven long back slats (P) from 1 x 4 pine, each measuring 35 inches long.
- Rip one long back slat (P) to a width of 2 inches.
- Cut eleven short back slats (Q) from 1 x 4 pine, each measuring 23 inches long.
- Note that the back of the daybed is two different heights. In order to connect the different heights, the upper top back (M) and the lower top back (N) must be mitered on one end, and the back connector (O) must be mitered on both ends. Refer to *Figure 11* and cut 45-degree miters on each of these three pieces. Make certain that the dadoed edge is on the lower side, as shown in the illustration.

Place the bottom back (L) on a level surface. Working from left to right, fit the ends of the eleven long back slats (P) in the bottom back (L), beginning with the 2-inch-wide back slat (P). Then fit the eleven short back slats (Q) into the same dado. Fit the long top back (M), the short top back (N), and the back connector (O) over the upper ends of the long and short backslats (P and Q). When the positions are perfect, the back assembly should measure 75-1/2 inches long. Secure the long and short back slats (P and Q) by nailing through the dadoed edge of the bottom back (L), the upper top back (M), lower top back (N) and back connector (O) into the ends of the slats (P and Q) using two 1-1/4-inch (3d) finishing nails on each joint.

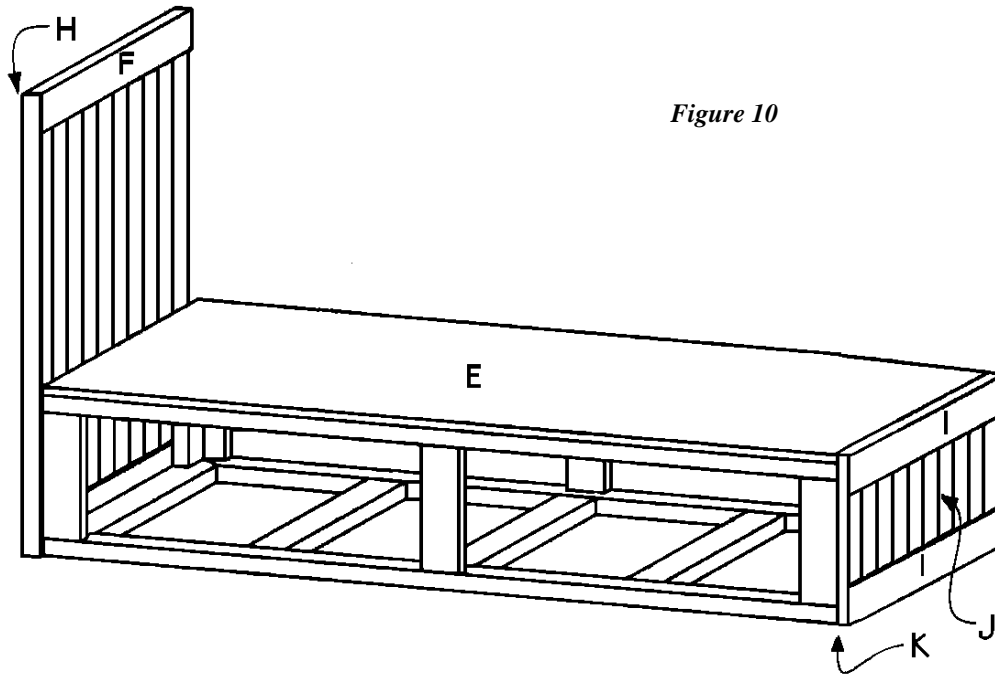

Figure 10

10. Cut one long back side (R) from 1 x 2 pine measuring 41 inches long.
11. Apply glue to the edge of the 2-inch slat (P) and attach the long back side (R) to the long side of the back assembly, as shown in *Figure 12*. Nail through the long back side (R) into the ends of the upper top back (M) and into the long back slat (P). Use 1-1/4-inch (3d) finishing nails spaced every five inches.
12. Cut one short back side (S) from 1 x 2 pine measuring 29 inches long.
13. Apply glue to the edge of the end slat (Q) and attach the short back side (S) to the short side of the back assembly, as shown in *Figure 12*. Nail through the short back side (S) into the ends of the lower top back (N) and into the short back slat (Q). Use 1-1/4-inch (3d) finishing nails spaced every five inches.

- Attach the back assembly to the back of the bed frame, as shown in *Figure 13*. Screw through the bottom of the back assembly into the bottom base frame. Also screw through the top of the back assembly into the top of the headboard assembly and through the short back side (S) into the top of the footboard assembly. Use 2-1/2-inch screws spaced about every 6 inches.

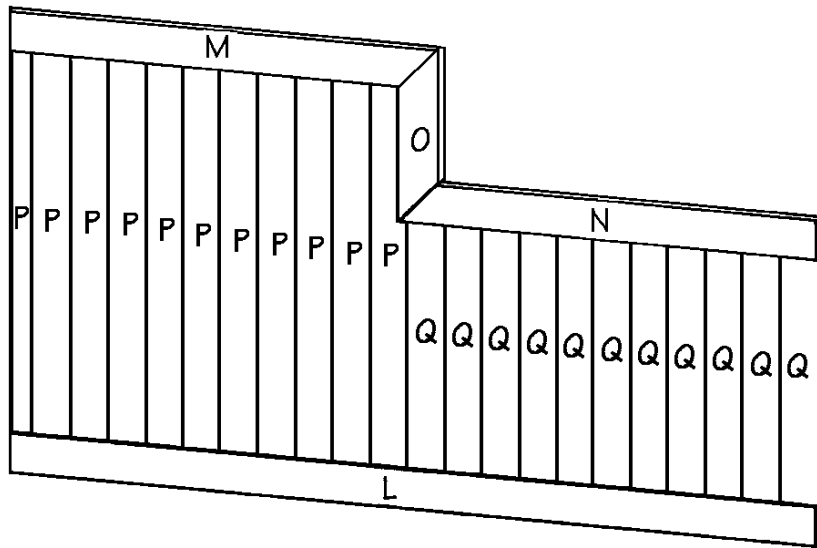

Figure 11

Adding the Front Trim

- Cut two horizontal trims (T) from 1 x 4 pine, each measuring 74 inches long.
- Cut three vertical trims (U) from 1 x 4 pine, each measuring 8-1/4 inches long.
- Attach one horizontal trim (T) between the headboard and the footboard flush with the bottom of the frame assembly, as shown in *Figure 14*. Use glue and 1 1/2-inch screws spaced about 6 inches apart.
- Attach each of the three vertical trims (U) to a front frame connector (D). Place the two outside vertical trims (U) against the headboard side (H) and the footboard side (K), respectively, but do not glue the vertical trim (U) to the headboard side (H). The third vertical trim (U) should be centered between the first two, as shown in *Figure 14*. Apply glue to the meeting surfaces and screw through each vertical trim (U) into its frame connector (D) using two 1 1/2-inch screws.
- Repeat step 4 to attach the remaining horizontal trim (T) between the headboard and footboard, against the tops of the vertical trims (U), as shown in *Figure 14*. This horizontal trim (T) extends above the platform (E) by 1/4 inch.
- Cut two storage fronts (V) from 1 x 12 pine, each measuring 33-3/4 inches long.

7. Center the storage fronts (V), both vertically and horizontally over the openings in the front of the completed daybed. Attach them to the daybed using two hinges on the bottom of each front. Install catches to keep the fronts closed. You may wish to round the front edges of the storage fronts (V) as we did.

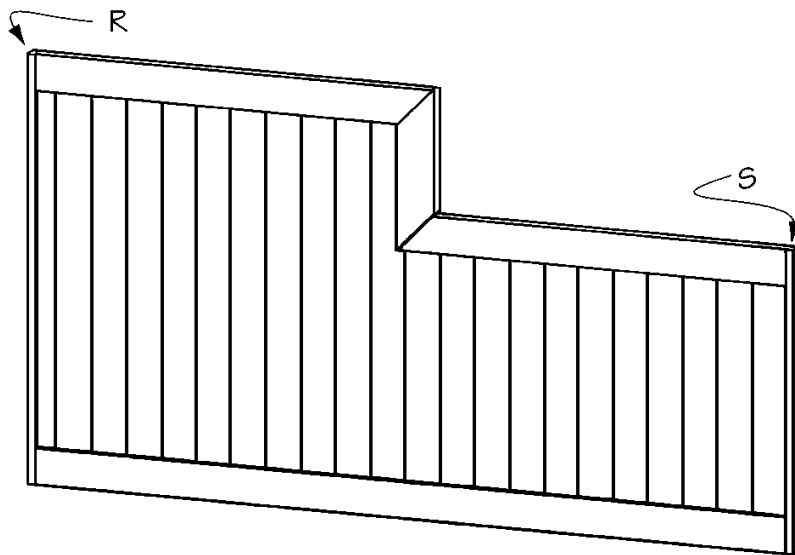

Figure 12

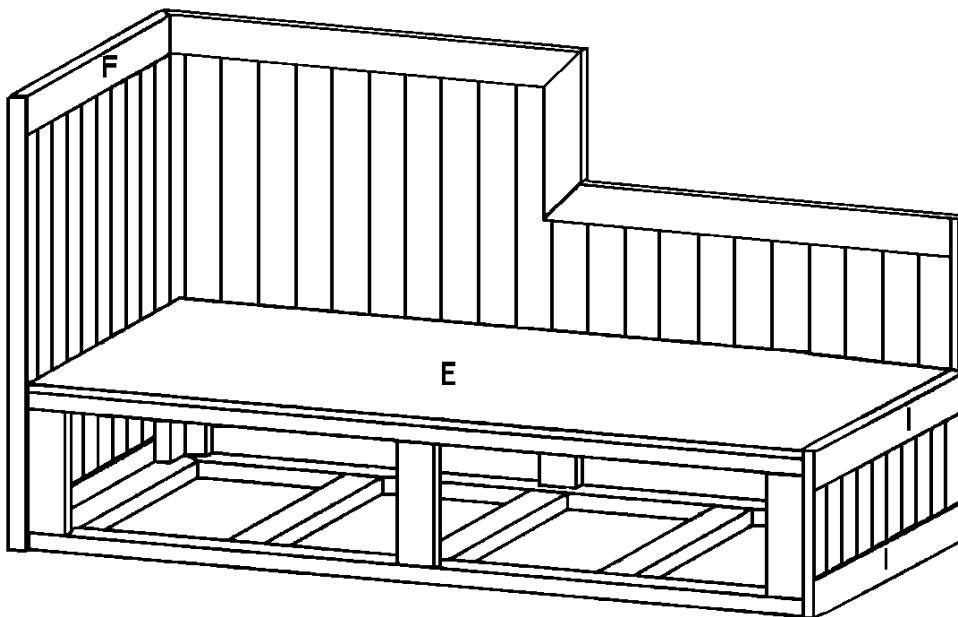

Figure 13

Finishing

1. Fill the screw holes, crevices and cracks with wood filler.
2. Sand all surfaces of the completed daybed.
3. Stain or paint the daybed the color of your choice. We chose to retain the natural color of the pine and simply sealed it with a glossy polyurethane.

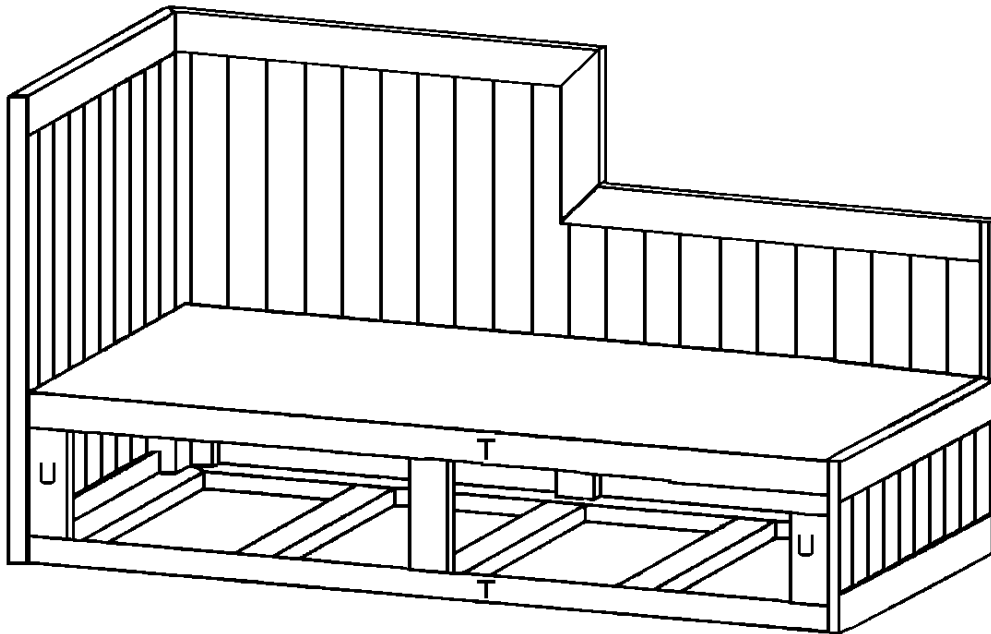

Figure 14

Try other bedroom (and bathroom, living room, kitchen, etc.) projects from !



Kitchen



Living Room