



Wow! I Made It.com

Desk Organizer

Too much work and not enough desk space? Make better use of your work surface with this handy organizer. There's room for scores of desk necessities, and the top surface is large enough to accommodate books and even a clock.



Materials List

- 12 linear feet of 1 x 12 pine
- 9 linear feet of 1 x 4 pine
- 6 linear feet of 3/4"-wide cove molding
- 6 linear feet of 3-1/4"-wide crown molding

Hardware

- 40 1" (2d) finish nails
- 20 1-1/4" wood screws
- 50 1-5/8" wood screws

Special Tools and Techniques

- Miter

Cutting List

Code	Description	Qty.	Materials	Dimensions
A	Vertical Divides	4	1 x 12 pine	9" long
B	Shelves	2	1 x 12 pine	11-5/8" long
C	Top/Bottom	2	1 x 12 pine	38" long
D	Front Trim	1	1 x 4 pine	40" long
E.	Side Trim	2	1 x 4 pine	12-1/4" long
F	Back Trim	1	1 x 4 pine	35" long
G	Cove Molding		3/4 x 3/4	Cut to fit
H	Crown Molding		3-1/4" wide	Cut to fit

Building the Center Compartments

1. Cut four Vertical Dividers (A) from 1 x 12 pine, each measuring 9 inches.
2. Cut two Shelves (B) from 1 x 12 pine, each measuring 11-5/8 inches.
3. Place two Vertical Dividers (A) on edge on a flat surface, parallel to each other, and 11-5/8 inches apart. Center one Shelf (B) horizontally between the two Vertical Dividers (A), as shown in *Figure 1*. Apply glue to the meeting surfaces, and screw through the Vertical

Dividers (A) into the edges of the Shelf (B), using three 1-5/8" wood screws.

- Repeat Step 3 to attach the remaining Shelf (B) to the remaining two Vertical Dividers (A).

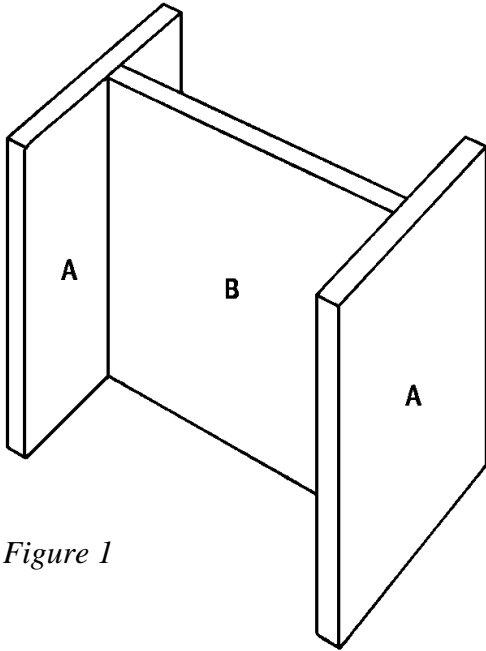

Figure 1

Adding the Top and Bottom

- Cut two Top/Bottoms (C) from 1 x 12 pine, each measuring 38 inches.
- Place one Top/Bottom (C) on edge, on a flat surface. Place one shelf assembly (A and B) 1-1/2 inches from one end of the Top/Bottom (C), as shown in *Figure 2*. Apply glue to the meeting surfaces, and screw through the Top/Bottom (C) into the ends of the Vertical Dividers (A). Use three 1-5/8" wood screws on each joint.
- Repeat Step 2 to attach the remaining shelf assembly (A) and B) 1-1/2 inches from the opposite end of the same Top/Bottom (C).

- Center the remaining Top/Bottom (C) over the assembly. It should overhang the outermost Vertical Dividers (A) by 1-1/2 inches on both ends. Apply glue to the meeting surfaces, and screw through the Top/Bottom (C) into each of the Vertical Dividers (A). Use three 1-5/8" wood screws on each joint.

Adding the Trim

- Cut one Front Trim (D) from 1 x 4 pine measuring 40 inches.
- Miter each end of the Front Trim (D) at opposing 45-degree angles, as shown in *Figure 3*.
- Cut two Side Trims (E) from 1 x 4 pine, each measuring 12-1/4 inches.
- Miter one end of each of the Side Trims (E) at a 45-degree angle, as shown in *Figure 4*.
- Place the Front Trim (D) over the edge of the Top/Bottom (C), as shown in *Figure 5*. The Front Trim (D) should overhang the Top/Bottom (C) by 1 inch on the front and both sides. Apply glue to the meeting surfaces, and screw through the Front Trim (D) into the Top/Bottom (C) using 1-5/8" wood screws spaced every 5 inches.

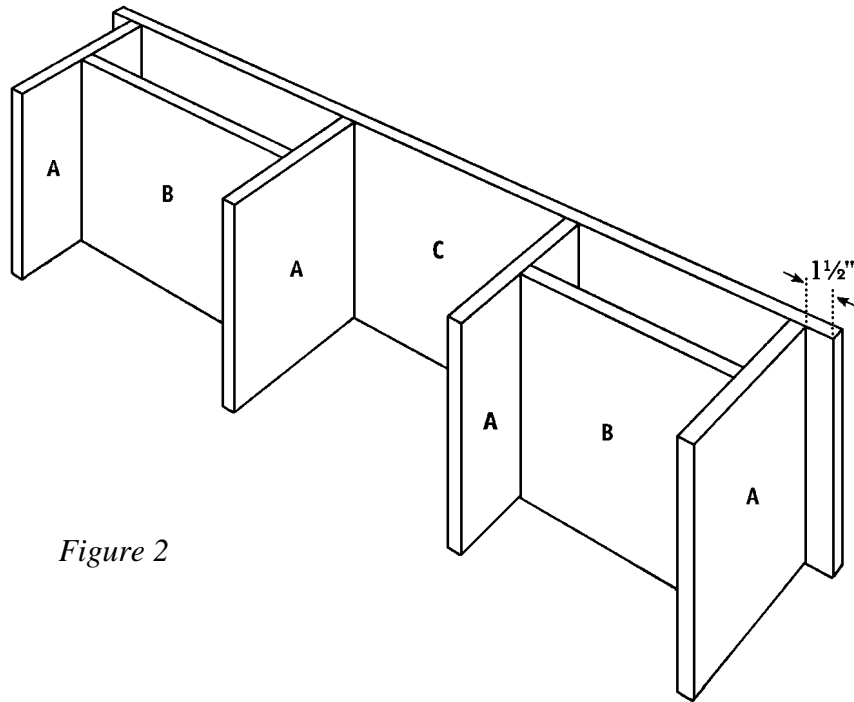

Figure 2

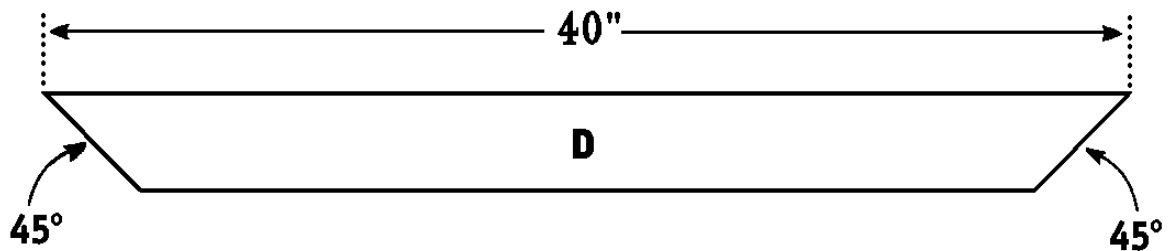

Figure 3

6. Place one Side Trim (E) over the ends of the Top/Bottom (C), with the miter toward the Front Trim (D), as shown in *Figure 5*. The trims should overhang the sides by 1 inch. Apply glue to the meeting surfaces, and screw through the Side Trim (E) into the Top/Bottom (C) using three 1-1/4" wood screws.
7. Repeat Step 6 to attach the remaining Side Trim (E) to the opposite end of the Top/Bottom (C).
8. Cut one Back Trim (F) from 1 x 4 pine measuring 35 inches.

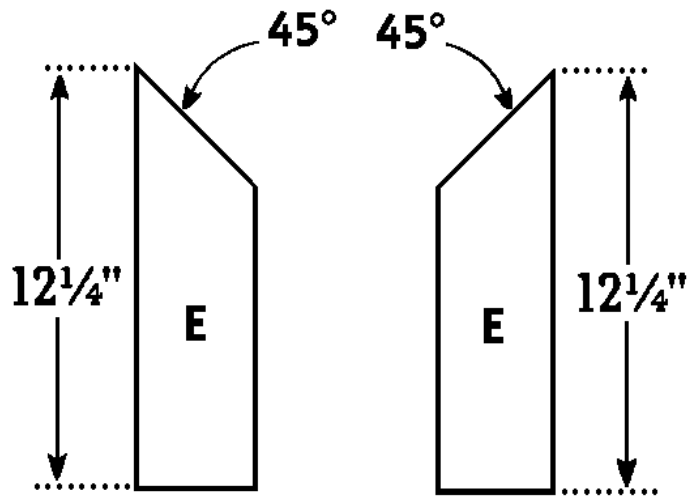

Figure 4

9. Fit the Back Trim (F) between the two Side Trims (E), flush with the back edge of the Top/Bottom (C), as shown in *Figure 5*. This piece does not overhang. Apply glue to the meeting surfaces, and screw through the Back Trim (F) into the Top/Bottom (C), using 1-5/8" wood screws spaced every 5 inches.

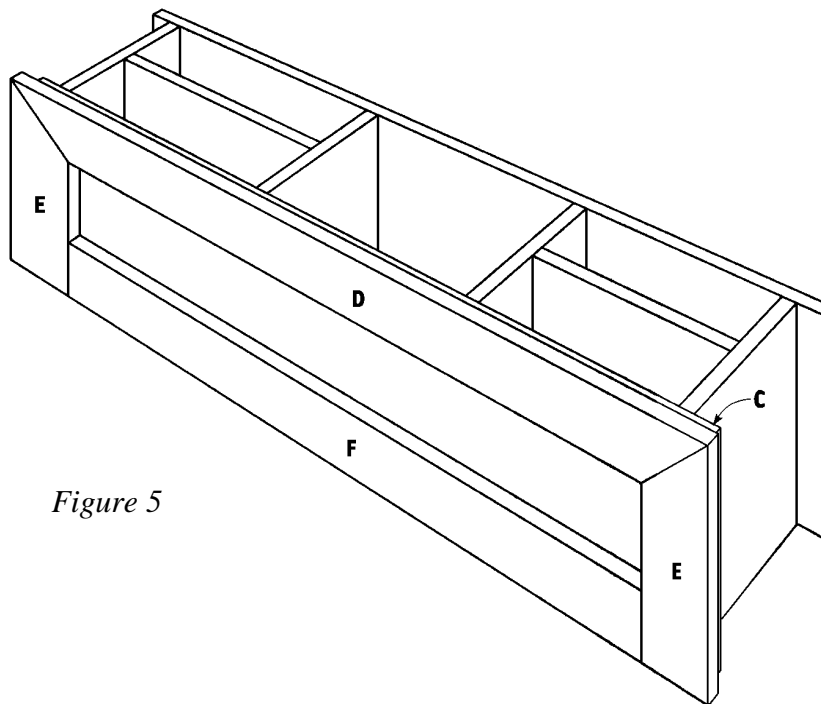

Figure 5

Adding the Molding

1. Turn the assembly so that the Front, Back and Side Trims (D, E, and F) are against the work surface. Cut and fit $\frac{3}{4}$ -wide Cove Molding (G) to cover the joints between the Top/Bottom (C) and the Front, Back and Side Trims (D, E, and F). The molding should be cut at a 45-degree angle to fit the front corner, except for the molding for the back of the organizer, which should be cut straight. Apply glue to the meeting surfaces, and nail through the Cove Molding (G) into the Top/Bottom (C) using 1" finishing nails.
2. Cut and fit 3-1/4-inch-wide Crown Molding (H) to fit around the remaining Top/Bottom (C), as shown in the photograph. Remember that the front corners are a compound 45-degree angle cut. Apply glue to the meeting surfaces, and nail through the Crown Molding (H) into the Top/Bottom (C) using 1" finishing nails.

Finishing

1. Fill any holes, cracks or crevices with wood filler.
2. Thoroughly sand all areas of the completed organizer.
3. Paint or stain the organizer with the color of your choice. We chose a honey maple stain, and then sealed it with satin polyurethane.



Enjoy many more indoor and outdoor projects from

