

3

CROTCH-GRAINED CHESS TABLE

Walnut, Poplar



MAKING THE CHESS TABLE

This piece is designed around a set of angles taken from the playing pieces, angles echoed in the fat dovetails holding the stretchers to the legs and to each other, in the big triangles cut from the apron parts, and in the compound angles used to bring the legs into the tabletop. The repetition of these angles—in addition to the consistent color of the walnut—unifies this piece.

Construction begins with the two sides (the faces of the table showing the wide sides of the legs). Fasten the apron parts to the legs with wide tenons glued only halfway across their widths in order to minimize the potential for cracking as these cross-grained constructions expand and contract in response to seasonal changes in humidity.

The creation of these joints is complicated by the compound angles at which the legs meet the tabletop. The tenon shoulders on the apron parts, for example, are cut at angles which are 83° from the top edges of these apron parts. The dovetailed ends of the stretcher are simpler to lay out, as these can be marked once the apron tenons have been dry-fit into their leg mortises.

Once dry-fit, glue and clamp these sub-assemblies—each of which consists of two legs, apron part, and stretcher.

On the table saw, give the center stretcher a dovetailed bottom that extends from end to end. Then fit this into dovetail mortises cut into the side stretchers. Surplus length is necessary on this stretcher so that the end grain can be pared back to the 83° angle at which the sides are canted. Then fasten the apron part opposite the drawer front to the legs on the back end of the table with a pair of 1/2"-long tenons. Again, in order to avoid cracking as a result of this cross-grained construction, glue the tenon only across half its width. Screw glue blocks into place behind this joint to reinforce these stubby tenons.

Resaw the drawer guide stock so that one face is canted at an 83° angle. Then, using a set of dado cutters on the table saw, plough a 1/2" X 5/8" groove down the center of the uncanted face of this stock. Cut the two drawer-guide pieces to length and install them on the inside faces of the apron sides.

The top is the next concern.

If woodworkers stay in the discipline long enough, they inevitably become wood collectors. My dad is no exception. Over the years he's put together a hoard of native hardwoods with an emphasis on black walnut, his personal favorite among American species. At the time this table was built, he had in his collection a number of short lengths of crotch-grained walnut he'd harvested several years before,

MATERIALS LIST

Table

A	Leg	4 pcs.	1 × 2¼ × 15¾
B	Apron (sides)		1 × 5¾ × 14¾ (includes 1" tenons on each end)
C	Apron (end)	2 pcs.	1 × 5¾ × 15¾ (includes ½" tenons on each end)
D	Stretcher (sides)	1 pc.	1 × 1½ × 15 (includes dovetailed ends)
E	Stretcher (center)	2 pcs.	1 × 2¼ × 18 (includes surplus to be sanded flush)
F	Glue block	1 pc.	7/8 × 7/8 × 5¼
G	Drawer guide	2 pcs.	7/8 × 3¼ × 13¾
H	Moulding (sides)	2 pcs.	1½ × 1¾ × 17¼
I	Moulding (end)	1 pc.	1½ × 1¾ × 18¾
J	Chessboard base	1 pc.	¼ × 14¾ × 14¾
K	Chessboard frame	4 pcs.	7/8 × 3¼ × 21¼
L	Frame spline	4 pcs.	¼ × 1½ × 5¾
M	Chessboard	1 pc.	½ × 13¾ × 13¾
N	Drawer stop strip	1 pc.	¾ × 1 × 14¾
O	Button	4 pcs.	¼ × ¾
P	Screws	various	

Drawer

Q	Front (apron)	1 pc.	1 × 5¾ × 14¾
R	Front spline	2 pcs.	¼ × ¾ × 5¾
S	Moulding	1 pc.	1½ × 1¾ × 18¾
T	Front shim	1 pc.	¾ × 3¾ × 12¾
U	Side	2 pcs.	¾ × 3¾ × 13¾
V	Back and front	2 pcs.	¾ × 3¾ × 11¾
W	Bottom	1 pc.	¼ × 12¼ × 12¼
X	Runner	2 pcs.	7/16 × 7/16 × 13¾
Y	Screws	various	

and he selected four of these for the top of this table because the swirling grain in the walnut echoed the swirling figure in the onyx frame of the chessboard.

Once you have chosen the stock for the chessboard frame, give it a shaped outside edge, and rabbet the bottom inside edge to receive the base on which the chessboard will set. Cut the slots for the splines. You can cut these by hand with a tenon saw, but I find it much easier to perform this operation on the table saw with a Universal Jig. (See

TOP VIEW

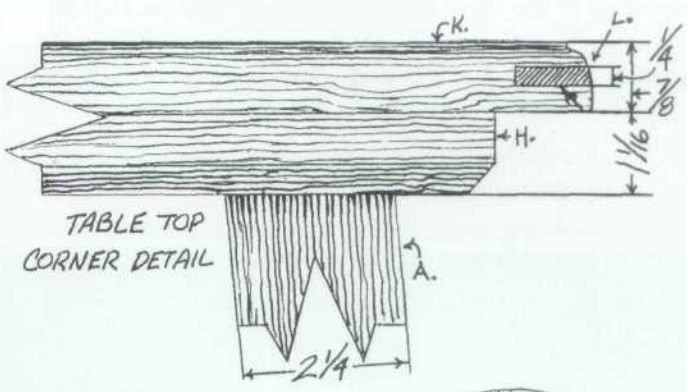
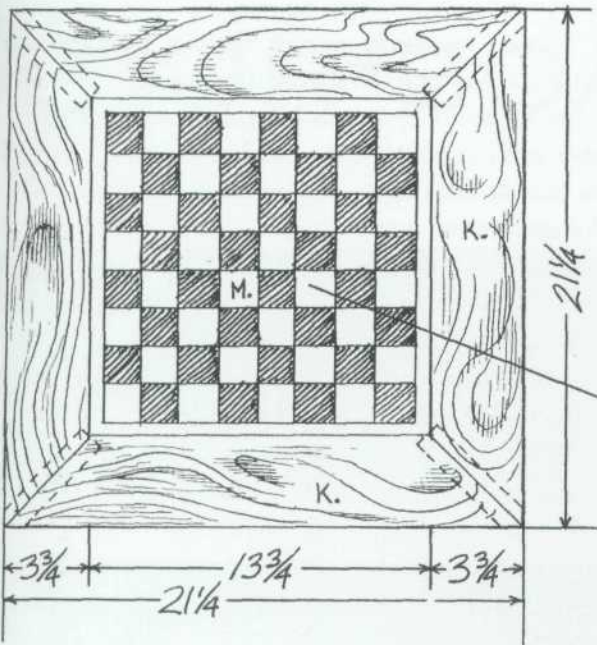
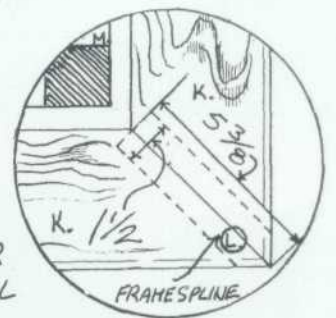
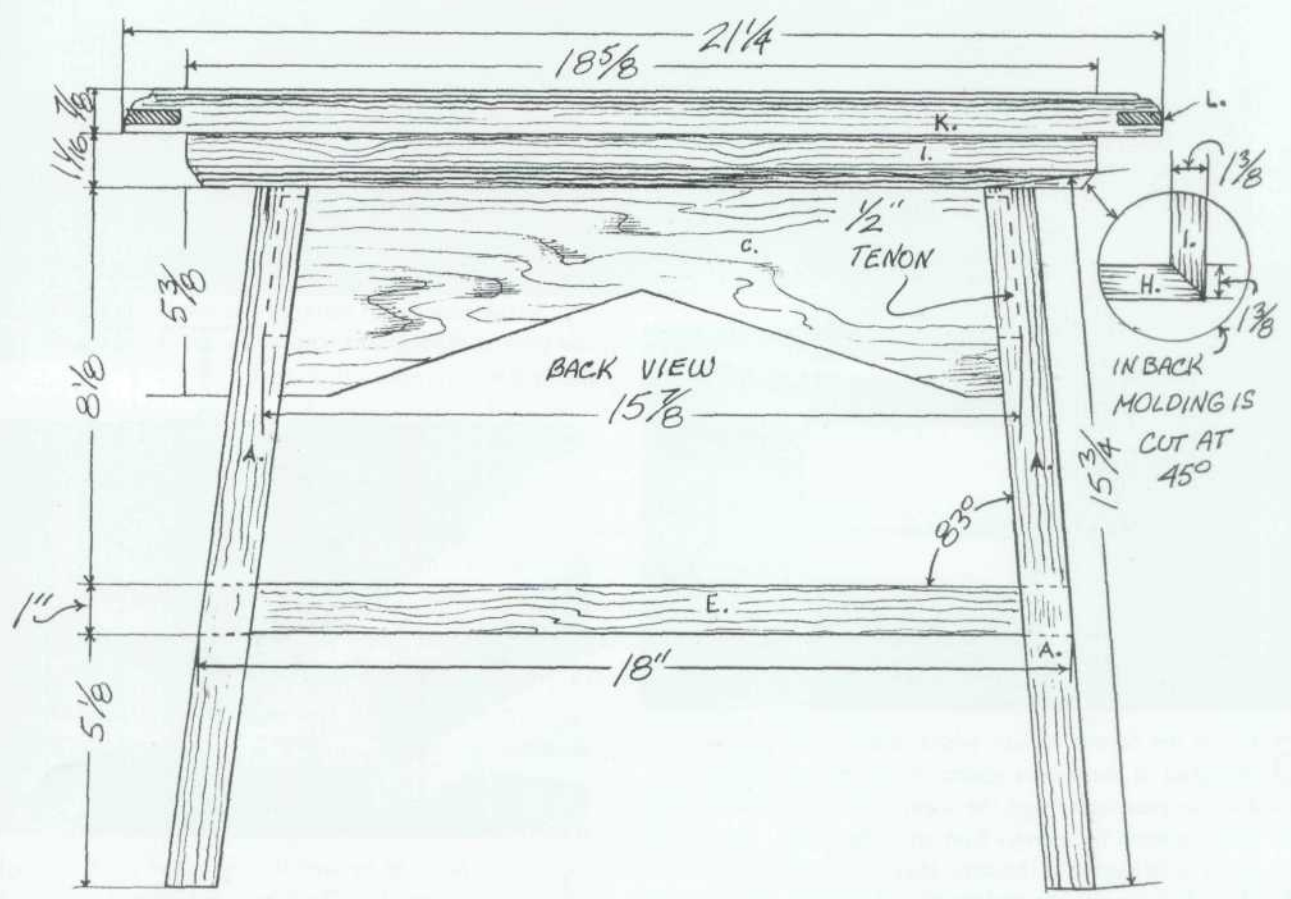

TABLE TOP CORNER DETAIL

BOARD IS 13 1/16 SQUARE



FRAME CORNER DETAIL



BACK VIEW

1/2" TENON

IN BACK MOLDING IS CUT AT 45°

chapter six for a photo of this jig in operation. Please note, however, that in order to cut the slots for the splines on the frame of the chess table, the work would be aligned so that the mitered end of the frame stock sets flat on the saw table). Thickness and cut splines, and assemble the frame.

Next, install the 1/4" chessboard base in its 1/4" X 1/2" rabbet with a number of small wood screws.

The moulding under the tabletop is not merely decorative—it's also functional, serving to fasten the top to the base via a number of wood screws passing up through the moulding into the top and passing through the apron into the moulding into the top and passing through the apron into the moulding.

The drawer is a simple open-topped, butt-jointed box, to the front end of which a section of the apron and the moulding are affixed so that when the drawer is closed,

both the apron and the moulding appear to run continuously around the table. Place a wedge of wood the full length of the drawer front, tapered from a bottom thickness of $\frac{5}{16}$ " to a top thickness of 0 between the drawer front and the apron that covers the drawer front. This shim causes the apron to be canted at the same 83° angle as the other sections of the apron. Slide the runners screwed to the outside faces of the drawer sides into the grooves ploughed in the drawer guides. Construct a drawer stop by screwing a strip of wood across the bottom of the drawer guides. When the drawer is opened to its greatest extension, a pair of screws turned slightly into the bottom edge of the drawer sides strike this strip, preventing the drawer from coming out too far and spilling its contents.

After finishing the table, set the chessboard into place on a felt pad.

1 Fasten the stretcher to the leg with a hand-cut dovetail

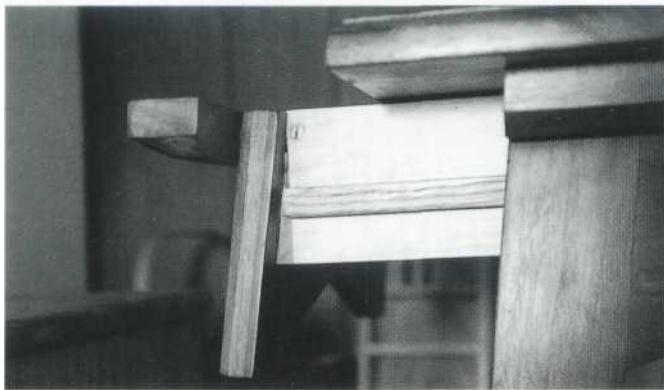
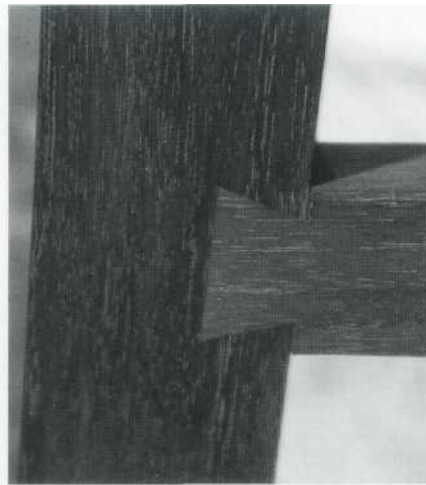

3 Fasten the drawer runner, which slides in the groove ploughed in the drawer guides, to the drawer via several wood screws passing through the drawer side into the slide. Note the shim between the drawer front and the apron. This causes the apron to be canted at the same angle as the table's legs. Note also the spline set into the end grain of the apron. This prevents the corners of the apron from breaking off because of the grain runout on the apron's triangular tips.



2 Screws passing up through this moulding into the top and passing through the apron into the moulding hold the top to the base.

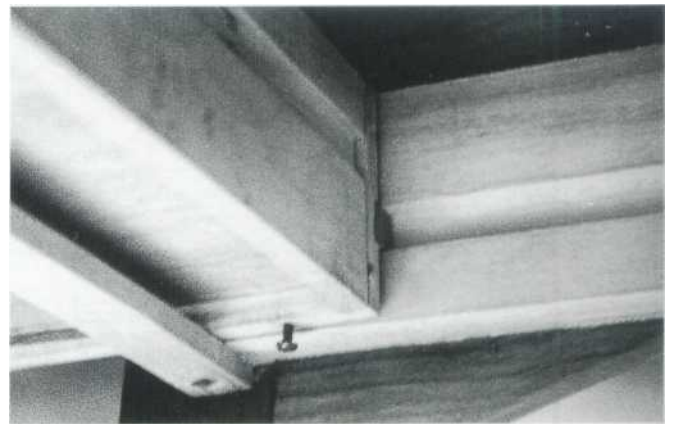

4 The drawer can be seen sliding in the groove ploughed in the drawer guide. When the screw turned into the bottom of the drawer side strikes the stop strip, the drawer is prevented from being pulled completely from the table.