

Power Play:

Exponents and Equations

5th
Grade

How can you write 2^3 in words?
Option 1: *Two to the third power*
Option 2: *Two to the power of three*

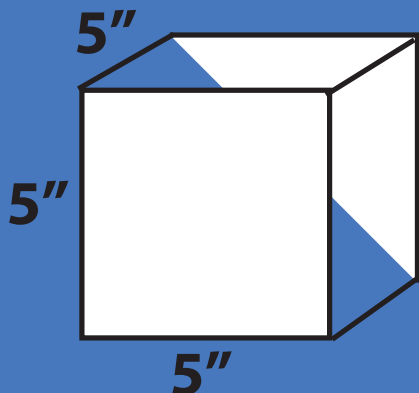

Multiplication
Expression: $5 \times 5 \times 5$

Exponent
Expression: 5^3

Value: **125**

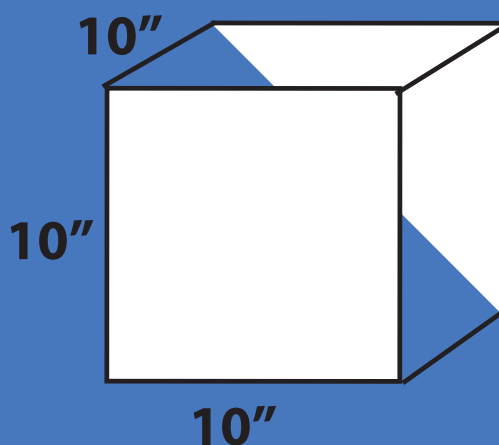

Multiplication
Expression: $10 \times 10 \times 10$

Exponent
Expression: 10^3

Value: **1000**

$$4(p + 6) - p$$

if $p = 1$

if $p = 10$

if $p = 6$

$$3r + 4^2$$

if $r = 2$

if $r = 5$

if $r = 10$

Table of Contents

Power Play: Exponents and Equations

- Introduction to Exponents: What Is an Exponent? *
- Introduction to Exponents: Understanding Key Terms *
- Introduction to Exponents: Exponents Make Numbers More Powerful *
- Exponents as Squares *
- Exponents as Cubes *
- Practice with Exponents: There's More Than One Way to Write a Number! *
- Word Problems Using Exponents *
- Evaluating Expressions: Order of Operations with Exponents *
- Evaluating Expressions Using Variables *
- From Words to Symbols: Test Your Math Vocabulary (Part One) *
- From Symbols to Words: Test Your Math Vocabulary (Part Two) *
- Write Equations: What Equals What? *
- Understanding Equations: Find the Missing Operation *
- Solving Equations Using Variables *
- Talking About Math: Important Vocabulary
- Certificate of Completion
- Answer Sheets

** Includes Answer Sheet*

Introduction to Exponents: What Is an Exponent?

An exponent is the simplest way to show how many times a number is multiplied by itself.

This example shows how to simplify an expression using exponents.

Example: $4 \times 4 \times 4 \times 4 \times 4$

The number 4 is multiplied by itself 5 times.

We can write

$$4^5$$

An **exponent** indicates how many times the base number is multiplied by itself.

The **base** is the number.

Write the following expressions using exponents.

$5 \times 5 \times 5 \longrightarrow \boxed{}$

$7 \times 7 \times 7 \times 7 \times 7 \times 7 \longrightarrow \boxed{}$

$3 \times 3 \times 3 \times 3 \longrightarrow \boxed{}$

$4 \times 4 \times 4 \times 4 \longrightarrow \boxed{}$

$9 \times 9 \longrightarrow \boxed{}$

$6 \times 6 \times 6 \times 6 \times 6 \longrightarrow \boxed{}$

$10 \times 10 \times 10 \times 10 \longrightarrow \boxed{}$

$1 \times 1 \times 1 \longrightarrow \boxed{}$

Introduction to Exponents: Understanding the Key Terms

It's important to understand the vocabulary we use when talking about exponents.

Factors are numbers we can multiply together to get another number.

Example: $2 \times 2 \times 2$ The factors are all 2.

The **base number** is the number that is going to be raised to a power.

Example: 2^3 The number 2 is the base number.

An **exponent** is the superscript number that tells you how many times its base is used as a factor.

Example: 2^3 3 is the exponent

The **value** of an exponent expression is the product of multiplying the base number by itself as indicated by the exponent.

Example: $2^3 = 2 \times 2 \times 2 = 8$

Let's Practice!

Take a close look at the numbers in each expression. Then, write your answers on the answer line.

1. 4^2

Write in expanded form (showing the factors) _____

Base number _____ Exponent _____ Value _____

2. 5^3

Write in expanded form (showing the factors) _____

Base number _____ Exponent _____ Value _____

3. 10^4

Write in expanded form (showing the factors) _____

Base number _____ Exponent _____ Value _____

4. 6^7

Write in expanded form (showing the factors) _____

Base number _____ Exponent _____ Value _____

Introduction to Exponents: Exponents Make Numbers More Powerful

It's no surprise that every time you multiply a number by another number, its value increases.

$2 \times 2 \times 2$ or 2^3 is definitely bigger and more powerful than 2.

How can you write 2^3 in words?

Option 1: *Two to the third power*

Option 2: *Two to the power of three*

Let's Practice Using These Terms

Write the following exponent expressions in words. You may choose either option above to write your answer.

1. 4^8 _____

2. 9^4 _____

3. 11^{20} _____

4. 3^8 _____

Write each problem in exponent form.

1. Thirty to the power of ten _____

2. Eighteen to the power of fifty-five _____

3. One hundred to the power of three _____

4. Seventeen to the power of sixteen _____

Find the value for each problem.

1. Twelve to the power of two _____

2. Three to the third power _____

3. Four to the power of six _____

4. Four to the power of four _____

Exponents as Squares

Whenever you use 2 as an exponent, you are multiplying a number by itself just one time.

Example: $5 \times 5 = 5^2$

Remember, you can write this in words as "five to the power of two" or "five to the second power."
You can also write it another way:

Five squared

How Are Squares Related to Exponents?

When you "square" a number, you are multiplying it by itself. This is the same formula for finding the area of a square.

Let's Practice!

Part 1

Record the answers for each problem on their answer lines.

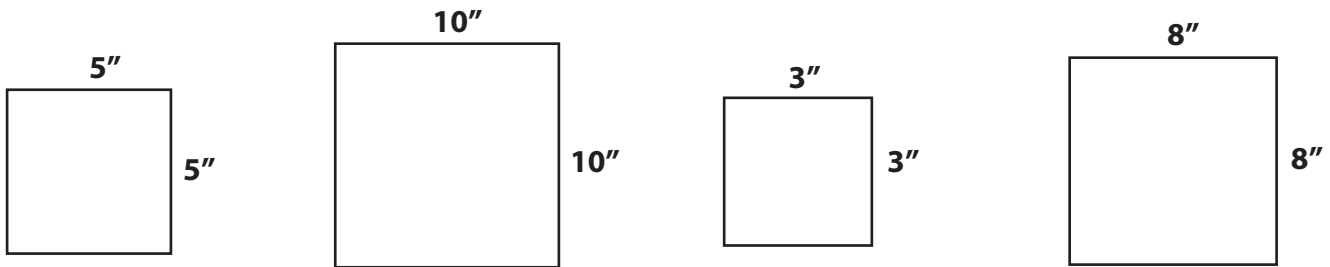

Multiplication
Expression: 5×5

Multiplication
Expression: _____

Multiplication
Expression: _____

Multiplication
Expression: _____

Exponent
Expression: 5^2

Exponent
Expression: _____

Exponent
Expression: _____

Exponent
Expression: _____

Value: 25

Value: _____

Value: _____

Value: _____

Part 2

Change the written form to its exponent form.

- Ten squared _____
- Fourteen squared _____
- Three hundred and fifty-six squared _____
- twelve squared _____

Exponents as Cubes

Whenever you use 3 as an exponent, you multiply a base number by itself twice.

Example: $2^3 = 2 \times 2 \times 2$

Remember, you can write this in words as "two to the power of three" OR "two to the third power."

You can also write it as:

Two cubed

How Are Cubes Related to Exponents?

When you "cube" a number you are multiplying it by itself two times. This is also how you find the volume of a cube.

Let's Practice

Part 1

Record the answers for each problem on their answer lines.

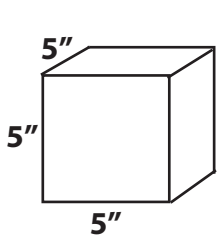

Multiplication
Expression: $5 \times 5 \times 5$

Exponent
Expression: 5^3

Value: 125

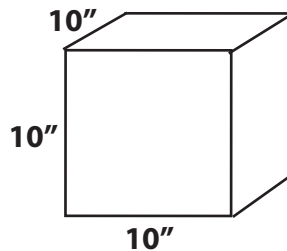

Multiplication
Expression: _____

Exponent
Expression: _____

Value: _____

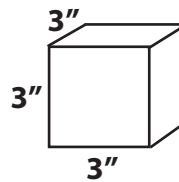

Multiplication
Expression: _____

Exponent
Expression: _____

Value: _____

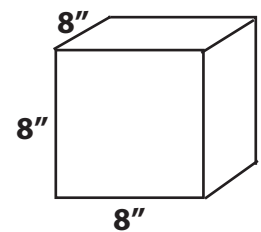

Multiplication
Expression: _____

Exponent
Expression: _____

Value: _____

Part 2

Change the written form to its exponent form.

1. Ten cubed 10^3

2. Five cubed _____

3. Four cubed _____

4. Nine cubed _____

Practice with Exponents: There's More Than One Way to Write a Number!

As you have seen, there are many ways to write or represent numbers that are multiplied by themselves.

Write the following problems in exponent form. The first problem has been completed for you.

1. $10 \times 10 \times 10$ 10^3

2. $2 \times 2 \times 2 \times 2$ _____

3. Seven to the power of ten _____

4. Nine cubed _____

Find the value of each problem. The first problem has been completed for you.

5. Three cubed 27

6. Two to the power of four _____

7. Five squared _____

8. 10^3 _____

Write the following problems in words. The first problem has been completed for you.

9. 17^3 Seventeen cubed

10. $3 \times 3 \times 3 \times 3 \times 3 \times 3$ _____

11. 8^6 _____

12. 60×60 _____

Word Problems Using Exponents

It's important to know when you can and cannot use exponents to solve a problem. There are two groups of word problems below. One group asks you to use exponents; the other doesn't.

Word Problems without Exponents

The first one has been completed for you.

1. Carla ate three cookies every day for a week. Show how many cookies she ate in a week.

Write an equation here: $3 \times 7 = \text{number of cookies}$ _____

Show the solution: 21 cookies _____

2. On Monday, Wednesday, and Thursday of last week, Carla read thirty pages each day in her independent reading book. How many total pages did she read last week?

Write an equation here: _____

Show the solution: _____

3. Carla has a dog walking service and makes \$9 for every day she works walking dogs. One week, she was sick and could only walk the dogs on 2 days. The following week, she felt better, so she worked 4 days. How much money did she make?

Write an equation here: _____

Show the solution: _____

4. Raymond drinks 7 glasses of water a day. How many glasses did he drink in a week?

Write an equation in standard form: $7 \times 7 = \text{total glasses of water}$ _____

Write an equation using exponents: $7^2 = \text{total glasses of water}$ _____

Show the solution: 49 _____

5. On school days (Monday, Tuesday, Wednesday, Thursday, and Friday), Raymond runs five laps around the track. How many laps does he run total?

Write an equation in standard form: _____

Write an equation using exponents: _____

Show the solution: _____

Evaluating Expressions: Order of Operations with Exponents

When you evaluate an expression—or find the total value—it's important to perform the operations in the proper order. What is the proper order?

Let me introduce you to a friend who can help you remember: PEMDAS! It's a funny name, but if you can remember it, you will always remember what to do first, next, and last.

P - Parentheses. If there are parentheses, evaluate what's in them first.

E - Exponents. If there are additional exponents, evaluate them next.

M - Multiplication. Then, multiply.

D - Division. Division comes next.

A - Addition. Addition and subtraction are done at the same time. Go left from right to determine the order.

S - Subtraction. This is the final step.

Evaluate the expressions below, paying attention to the order of operations. Show the steps. The first one has been completed for you.

1) $(8 - 4) \times 5^3 - 10$

$4 \times 5^3 - 10$

$4 \times 125 - 10$

$500 - 10$

490

2) $2^2 \times 9 + 5$

3) $33 - (48 \div 4) + 7$

4) $52 + (18 - 9) - 2^2$

5) $(29 - 7) \times 7^2 + 6$

6) $58 - (36 \div 4) + 8$

Evaluating Expressions Using Variables

What is a variable? A variable stands for a value that isn't known.

Example: $5 \times r$

In this example, r stands for a value. Until you know what it stands for, you cannot evaluate this expression.

So, if $r = 10$, the value of this expression would be 50 because $5 \times 10 = 50$.

If $r = 2$, what would the value be? If you said 10, you would be right!

Evaluate the expressions below using different values for the variable. The first one has been completed for you. Remember to pay attention to the order of operations.

1. $31k$ (same as $31 \times k$)

if $k = 4$

124

if $k = 10$

310

if $k = 2$

62

2. $4(p + 6) - p$

if $p = 1$

if $p = 10$

if $p = 6$

3. $9^2 - (f - 1)$

if $f = 1$

if $f = 2$

if $f = 20$

4. $3r^2 + 4$

if $r = 2$

if $r = 5$

if $r = 10$

From Words to Symbols: Test Your Math Vocabulary

Here is a good way to test your knowledge of math vocabulary and your math reasoning. On this worksheet, you will translate words into math expressions.

Example:

Written in words: Subtract five from six times ten.

Written as a math expression: $6 \times 10 - 5$

Notice that the minus five is at the end. That's what makes subtraction a bit tricky to write in words.

Here is a more challenging example:

Written in words: Multiply the sum of six plus four by two to the second power.

Written as a math expression: $2^2 (6 + 4)$

Now you try! Rewrite the sentences below as math expressions.

1. Multiply the sum of two plus five by ten and subtract five.

2. Multiply the difference between seven and three by five and add 2.

3. Divide one hundred by five squared.

4. Add ten to the power of three to the variable r.

5. Subtract the variable p from the product of ten times three.

From Symbols to Words: Test Your Math Vocabulary II

Now that you've had practice translating words into math expressions, it's time to try the reverse and translate the math expression into words. It's a challenge, but it's a good way to improve your understanding of what you're doing when you evaluate an expression. Pretend that you have to give someone very clear instructions using only words.

Example:

Written as a math expression: $4(25 + 5) / 2$

Written in words: Multiply the sum of twenty-five plus five by four and divide the product by two.

You might find the following words helpful:

Sum: The answer you get when you add.

Product: The answer you get with you multiply.

Difference: The answer you get when you subtract.

Quotient: The answer you get when you divide.

Write the following math expressions in words. The first problem has been completed for you. Remember, there are different ways to write out each expression.

1. $10(25-9) + 8$

Multiply the difference between twenty-five and nine by ten and add eight.

2. $3^3 + 100$

3. $18 \div r - 10$

4. $3(4-1)$

5. $(50 + 10) \div 2$

6. $5^2 - 5$

7. $5 + 2 \times 7 - 1$

Write Equations: What Equals What?

Equations are number sentences with equal signs. They show how two quantities are equal. One way of thinking about equations is that they are two expressions that have the same value and are joined by an equal sign.

$5 + 2 = 7$ is an equation The value of both sides is 7.

But so is this:

$5^2 (10-5) = 25 \times 5$ The value of both sides is 125.

and this:

$10(5-2) + 1 = 11 + 20$ The value of both sides is 31.

In this worksheet you will be given an expression and asked to write another expression of equal value to create an equation. Try to use multiplication, division, and exponents whenever possible. Get creative! Think about all the ways you can make a 1 by just subtracting one number from another, such as $9 - 8$.

Hint: First evaluate the expression. Then, find another way to write that number.

1. $10 \times 3 + 5 =$ _____

2. $10^2 + 1 =$ _____

3. $50 / 2 + 3 =$ _____

4. $10 \times 10 \times 10 + 30 =$ _____

5. $75 \times 2 =$ _____

Understanding Equations: Find the Missing Operation

Now that you understand how to make both sides of an equation equal, try this exercise. Add the operation symbols: addition (+), subtraction (-), multiplication (x), or division (÷) to complete the equation.

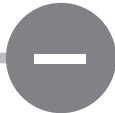

$(20 \text{ } \text{ } 12) + 7 = 15$

$(31 \text{ } \text{ } 3) - 5 = 29$

$(4 \text{ } \text{ } 18) + 8 = 80$

$(9 \text{ } \text{ } 9) + 9 = 10$

$(14 \text{ } \text{ } 2) + 5 = 12$

$(7 \text{ } \text{ } 21) - 4 = 24$

$(14 \text{ } \text{ } 6) + 6 = 90$

$(22 \text{ } \text{ } 11) + 9 = 11$

$(12 \text{ } \text{ } 2) - 5 = 19$

$(15 \text{ } \text{ } 3) + 7 = 52$

$(8 \text{ } \text{ } 4) - 5 = 27$

$(6 \text{ } \text{ } 15) + 6 = 27$

Solving Equations Using Variables

Equations can be used to find the value of variables. Simple equations can be solved using mental math.

Example: $22 - y = 20$

What number would you use to replace y that would make the equation true? If you answered 2, you would be correct.

$$22 - 2 = 20$$

In the following simple equations, you will be using mental math to find the value of the variables.

1. $3 \times y = 30$

$y =$ _____

2. $5 + 1 \times n = 36$

$n =$ _____

3. $2^2 - r = 0$

$r =$ _____

4. $3^3 - x = 7$

$x =$ _____

5. $4 \times 2 \times n = 32$

$n =$ _____

6. $n - 30 = 55$

$n =$ _____

7. $8x = 64$

$x =$ _____

8. $45 \div p = 5$

$p =$ _____

Try these challenge equations. First, find the value of the expression that doesn't contain a variable.

9. $20 + y = 5^3 + 2$

$y =$ _____

10. $12 \times n + 10 = 12^2 + (2 \times 5)$

$n =$ _____

Glossary

Talking About Math: Important Vocabulary

Factors: Numbers that are multiplied to make another number. Example: 5 x 2 are both factors that can be multiplied to make 10.

Expression: A number sentence using numbers and operations to express a quantity.
Example: $5 + 20$.

Equation: A number sentence using numbers and operations to show how two quantities are equal. Includes an equal sign. Example: $5 + 20 = 25$.

Exponent: A number showing how many times the base number is multiplied by itself.
Example: 2^3 (the exponent is the **3**).

Base number: A number that is multiplied by itself. Example: 2^3 (the base number is **2**).

Product: The number that results when numbers are multiplied. Example: $2 \times 5 = 10$. 10 is the product.

Sum: The number that results when numbers are added. Example: $2 + 5 = 7$. 7 is the sum.

Difference: The number that results when numbers are subtracted. Example: $7 - 5 = 2$. 2 is the difference between 7 and 5.

Quotient: The number that results when numbers are divided. Example: $10/2 = 5$. 5 is the quotient.

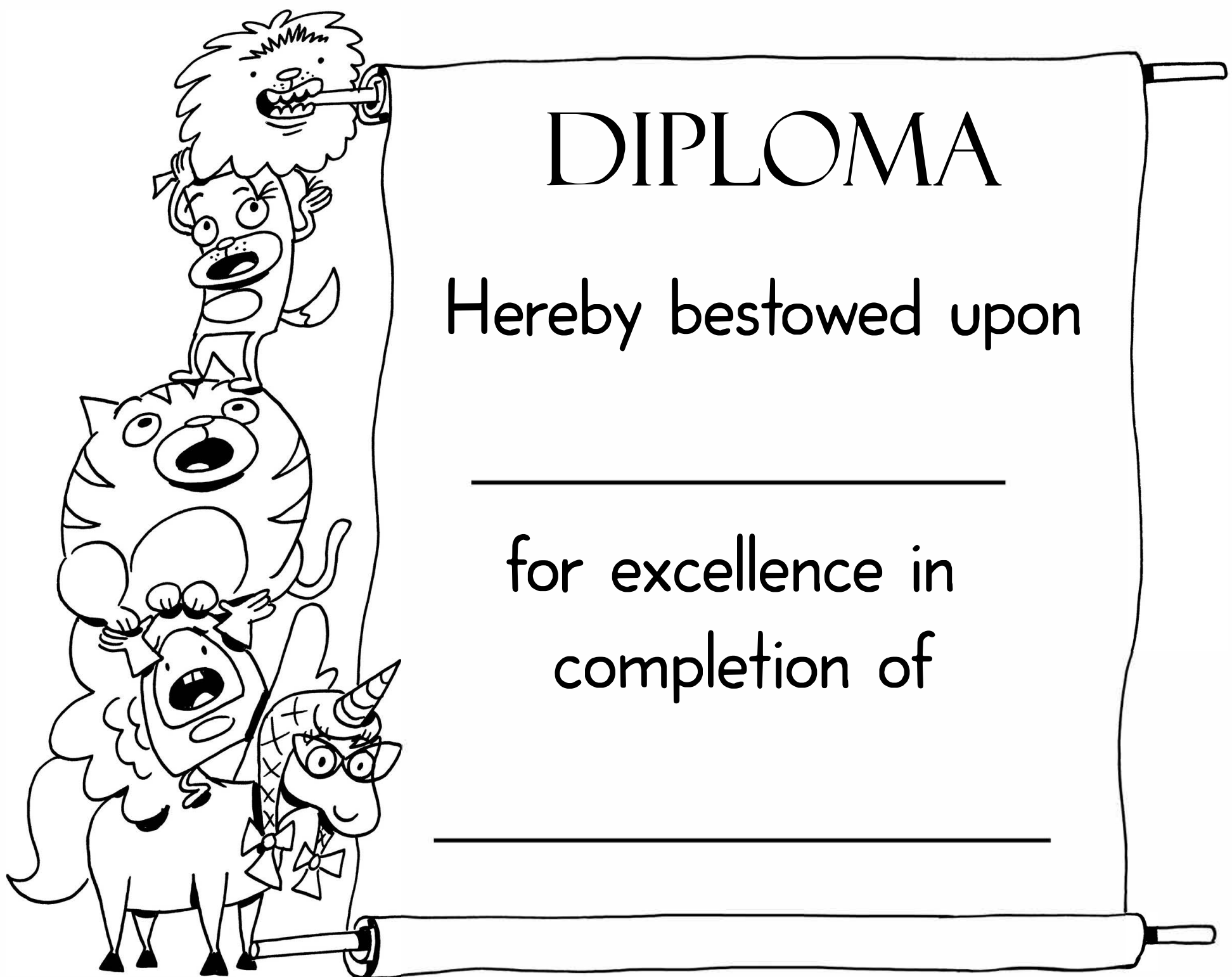

DIPLOMA

Hereby bestowed upon

for excellence in
completion of

Answer Sheets

Power Play: Exponents and Equations

- Introduction to Exponents: What Is an Exponent?
- Introduction to Exponents: Understanding Key Terms
- Introduction to Exponents: Exponents Make Numbers More Powerful
 - Exponents as Squares
 - Exponents as Cubes
- Practice with Exponents: There's More Than One Way to Write a Number!
 - Word Problems Using Exponents
- Evaluating Expressions: Order of Operations with Exponents
 - Evaluating Expressions Using Variables
- From Words to Symbols: Test Your Math Vocabulary (Part One)
- From Symbols to Words: Test Your Math Vocabulary (Part Two)
 - Write Equations: What Equals What?
- Understanding Equations: Find the Missing Operation
 - Solving Equations Using Variables

Answer Sheet

Name _____

Date _____

Introduction to Exponents: What Is an Exponent?

ANSWERS

An exponent is the simplest way to show how many times a number is multiplied by itself.

This example shows how to simplify an expression using exponents.

Example: $4 \times 4 \times 4 \times 4 \times 4$

The number 4 is multiplied by itself 5 times.

We can write

$$4^5$$

An **exponent** indicates how many times the base number is multiplied by itself.

The **base** is the number.

Write the following expressions using exponents.

$5 \times 5 \times 5$

→

5^3

$7 \times 7 \times 7 \times 7 \times 7 \times 7$

→

7^6

$3 \times 3 \times 3 \times 3$

→

3^4

$4 \times 4 \times 4 \times 4$

→

4^4

9×9

→

9^2

$6 \times 6 \times 6 \times 6 \times 6$

→

6^5

$10 \times 10 \times 10 \times 10$

→

10^4

$1 \times 1 \times 1$

→

1^3

Answer Sheet

Name _____

Date _____

ANSWERS

Introduction to Exponents: Understanding the Key Terms

It's important to understand the vocabulary we use when talking about exponents.

Factors are numbers we can multiply together to get another number.

Example: $2 \times 2 \times 2$ The factors are all 2.

The **base number** is the number that is going to be raised to a power.

Example: 2^3 The number 2 is the base number.

An **exponent** is the superscript number that tells you how many times its base is used as a factor.

Example: 2^3 3 is the exponent

The **value** of an exponent expression is the product of multiplying the base number by itself as indicated by the exponent.

Example: $2^3 = 2 \times 2 \times 2 = 8$

Let's Practice!

Take a close look at the numbers in each expression. Then, write your answers on the answer line.

1. 4^2

Write in expanded form (showing the factors) 4 X 4

Base number 4 Exponent 2 Value 16

2. 5^3

Write in expanded form (showing the factors) 5 X 5 X 5

Base number 5 Exponent 3 Value 125

3. 10^4

Write in expanded form (showing the factors) 10 X 10 X 10 X 10

Base number 10 Exponent 4 Value 10,000

4. 6^7

Write in expanded form (showing the factors) 6 X 6 X 6 X 6 X 6 X 6 X 6

Base number 6 Exponent 7 Value 279,936

Answer Sheet

Name _____

Date _____

Introduction to Exponents: Exponents Make Numbers More Powerful

It's no surprise that every time you multiply a number by another number, its value increases.

$2 \times 2 \times 2$ or 2^3 is definitely bigger and more powerful than 2.

How can you write 2^3 in words?

Option 1: *Two to the third power*

Option 2: *Two to the power of three*

ANSWERS

Let's Practice Using These Terms

Write the following exponent expressions in words. You may choose either option above to write your answer.

1. 4^8 four to the eighth power OR four to the power of eight

2. 9^4 nine to the fourth power OR nine to the power of four

3. 11^{20} eleven to the twentieth power OR eleven to the power of twenty

4. 3^8 three to the eighth power OR three to the power of eight

Write each problem in exponent form.

1. Thirty to the power of ten 30^{10}

2. Eighteen to the power of fifty-five 18^{55}

3. One hundred to the power of three 100^3

4. Seventeen to the power of sixteen 17^{16}

Find the value for each problem.

1. Twelve to the power of two 144

2. Three to the third power 27

3. Four to the power of six 4,096

4. Four to the power of four 256

Answer Sheet

Name _____

Date _____

Exponents as Squares

Whenever you use 2 as an exponent, you are multiplying a number by itself just one time.

ANSWERS

Example: $5 \times 5 = 5^2$

Remember, you can write this in words as “five to the power of two” or “five to the second power.” You can also write it another way:

Five squared

How Are Squares Related to Exponents?

When you “square” a number, you are multiplying it by itself. This is the same formula for finding the area of a square.

Let's Practice!

Part 1

Record the answers for each problem on their answer lines.

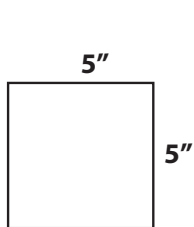

Multiplication
Expression: 5×5

Exponent
Expression: 5^2

Value: 25

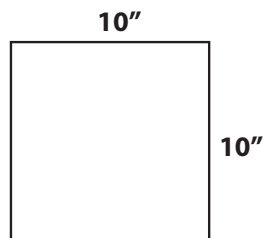

Multiplication
Expression: 10×10

Exponent
Expression: 10^2

Value: 100

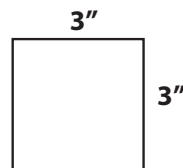

Multiplication
Expression: 3×3

Exponent
Expression: 3^2

Value: 9

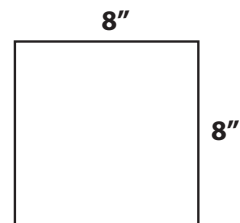

Multiplication
Expression: 8×8

Exponent
Expression: 8^2

Value: 64

Part 2

Change the written form to its exponent form.

1. Ten squared 10^2

2. Fourteen squared 14^2

3. Three hundred and fifty-six squared 356^2

4. twelve squared 12^2

Answer Sheet

Name _____

Date _____

ANSWERS

Exponents as Cubes

Whenever you use 3 as an exponent, you multiply a base number by itself twice.

Example: $2^3 = 2 \times 2 \times 2$

Remember, you can write this in words as "two to the power of three" OR "two to the third power."

You can also write it as:

Two cubed

How Are Cubes Related to Exponents?

When you "cube" a number you are multiplying it by itself two times. This is also how you find the volume of a cube.

Let's Practice

Part 1

Record the answers for each problem on their answer lines.

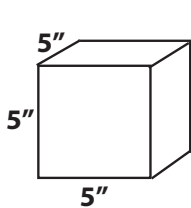

Multiplication
Expression: $5 \times 5 \times 5$

Exponent
Expression: 5^3

Value: 125

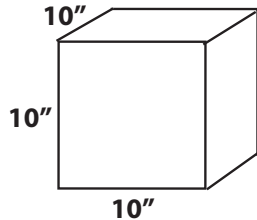

Multiplication
Expression: $10 \times 10 \times 10$

Exponent
Expression: 10^3

Value: 1000

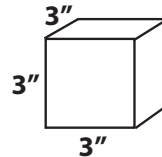

Multiplication
Expression: $3 \times 3 \times 3$

Exponent
Expression: 3^3

Value: 27

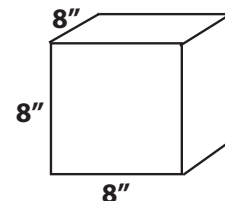

Multiplication
Expression: $8 \times 8 \times 8$

Exponent
Expression: 8^3

Value: 512

Part 2

Change the written form to its exponent form.

1. Ten cubed 10^3

2. Five cubed 5^3

3. Four cubed 4^3

4. Nine cubed 9^3

Answer Sheet

Name _____

Date _____

Practice with Exponents: There's More Than One Way to Write a Number!

As you have seen, there are many ways to write or represent numbers that are multiplied by themselves.

Write the following problems in exponent form. The first problem has been completed for you.

1. $10 \times 10 \times 10$ 10^3 2. $2 \times 2 \times 2 \times 2$ 2^4

3. Seven to the power of ten 7^{10} 4. Nine cubed 9^3

Find the value of each problem. The first problem has been completed for you.

5. Three cubed 27 6. Two to the power of four 16

7. Five squared 25 8. 10^3 1,000

Write the following problems in words. The first problem has been completed for you.

9. 17^3 Seventeen cubed 10. $3 \times 3 \times 3 \times 3 \times 3 \times 3$ Three to the power of six

11. 8^6 Eight to the power of six 12. 60×60 Sixty squared

Answer Sheet

Name _____

Date _____

ANSWERS

Word Problems Using Exponents

It's important to know when you can and cannot use exponents to solve a problem. There are two groups of word problems below. One group asks you to use exponents; the other doesn't.

Word Problems without Exponents

The first one has been completed for you.

1. Carla ate three cookies every day for a week. Show how many cookies she ate in a week.

Write an equation here: $3 \times 7 = \text{number of cookies}$

Show the solution: 21 cookies

2. On Monday, Wednesday, and Thursday of last week, Carla read thirty pages each day in her independent reading book. How many total pages did she read last week?

Write an equation here: $3 \times 30 = \text{number of pages}$

Show the solution: 90 pages

3. Carla has a dog walking service and makes \$9 for every day she works walking dogs. One week, she was sick and could only walk the dogs on 2 days. The following week, she felt better, so she worked 4 days. How much money did she make?

Write an equation here: $(2 \times 9) + (4 \times 9) = \text{money earned}$ OR $9 \times (2 + 4) = \text{money earned}$
 $18 + 36 = \text{money earned}$ OR $9 \times 6 = \text{money earned}$

Show the solution: 54

4. Raymond drinks 7 glasses of water a day. How many glasses did he drink in a week?

Write an equation in standard form: $7 \times 7 = \text{total glasses of water}$

Write an equation using exponents: $7^2 = \text{total glasses of water}$

Show the solution: 49

5. On school days (Monday, Tuesday, Wednesday, Thursday, and Friday), Raymond runs five laps around the track. How many laps does he run total?

Write an equation in standard form: $5 \times 5 = \text{total number of laps}$

Write an equation using exponents: $5^2 = \text{total number of laps}$

Show the solution: 25

Answer Sheet

Name _____

Date _____

Evaluating Expressions: Order of Operations with Exponents

When you evaluate an expression—or find the total value—it's important to perform the operations in the proper order. What is the proper order?

Let me introduce you to a friend who can help you remember: PEMDAS! It's a funny name, but if you can remember it, you will always remember what to do first, next, and last.

P - Parentheses. If there are parentheses, evaluate what's in them first.

E - Exponents. If there are additional exponents, evaluate them next.

M - Multiplication. Then, multiply.

D - Division. Division comes next.

A - Addition. Addition and subtraction are done at the same time. Go left from right to determine the order.

S - Subtraction. This is the final step.

Evaluate the expressions below, paying attention to the order of operations. Show the steps. The first one has been completed for you.

1) $(8 - 4) \times 5^3 - 10$

$4 \times 5^3 - 10$

$4 \times 125 - 10$

$500 - 10$

490

2) $2^2 \times 9 + 5$

$4 \times 9 + 5$

$36 + 5$

41

3) $33 - (48 \div 4) + 7$

$33 - 12 + 7$

$21 + 7$

28

4) $52 + (18 - 9) - 2^3$

$52 + 9 - 2^3$

$52 + 9 - 8$

$61 - 8$

53

5) $(29 - 7) \times 7^2 + 6$

$22 \times 7^2 + 6$

$22 \times 49 + 6$

$1,078 + 6$

$1,084$

6) $58 - (36 \div 4) + 8$

$58 - 9 + 8$

$49 + 8$

57

Answer Sheet

Name _____

Date _____

ANSWERS Evaluating Expressions Using Variables

What is a variable? A variable stands for a value that isn't known.

Example: $5 \times r$

In this example, r stands for a value. Until you know what it stands for, you cannot evaluate this expression.

So, if $r = 10$, the value of this expression would be 50 because $5 \times 10 = 50$.

If $r = 2$, what would the value be? If you said 10, you would be right!

Evaluate the expressions below using different values for the variable. The first one has been completed for you. Remember to pay attention to the order of operations.

1. $31k$ (same as $31 \times k$)

if $k = 4$

124

if $k = 10$

310

if $k = 2$

62

2. $4(p + 6) - p$

if $p = 1$

27

if $p = 10$

54

if $p = 6$

42

3. $9^2 - (f - 1)$

if $f = 1$

81

if $f = 2$

80

if $f = 20$

62

4. $3r^2 + 4$

if $r = 2$

16

if $r = 5$

79

if $r = 10$

304

Answer Sheet

Name _____

Date _____

From Words to Symbols: Test Your Math Vocabulary

ANSWERS

Here is a good way to test your knowledge of math vocabulary and your math reasoning. On this worksheet, you will translate words into math expressions.

Example:

Written in words: Subtract five from six times ten.

Written as a math expression: $6 \times 10 - 5$

Notice that the minus five is at the end. That's what makes subtraction a bit tricky to write in words.

Here is a more challenging example:

Written in words: Multiply the sum of six plus four by two to the second power.

Written as a math expression: $2^2 (6 + 4)$

Now you try! Rewrite the sentences below as math expressions.

1. Multiply the sum of two plus five by ten and subtract five.

$10(2 + 5) - 5$

2. Multiply the difference between seven and three by five and add 2.

$5(7 - 3) + 2$

3. Divide one hundred by five squared.

$100 / 5^2$

4. Add ten to the power of three to the variable r.

$10^3 + r$

5. Subtract the variable p from the product of ten times three.

$10 \times 3 - p$

Answer Sheet

Name _____

Date _____

ANSWERS

From Symbols to Words: Test Your Math Vocabulary II

Now that you've had practice translating words into math expressions, it's time to try the reverse and translate the math expression into words. It's a challenge, but it's a good way to improve your understanding of what you're doing when you evaluate an expression. Pretend that you have to give someone very clear instructions using only words.

Example:

Written as a math expression: $4(25 + 5) / 2$

Written in words: Multiply the sum of twenty-five plus five by four and divide the product by two.

You might find the following words helpful:

Sum: The answer you get when you add.

Product: The answer you get with you multiply.

Difference: The answer you get when you subtract.

Quotient: The answer you get when you divide.

Write the following math expressions in words. The first problem has been completed for you. Remember, there are different ways to write out each expression.

1. $10(25-9) + 8$

Multiply the difference between twenty-five and nine by ten and add eight.

2. $3^3 + 100$

Find the value of three cubed (or three to the power of three) and add one hundred.

3. $18 \div r - 10$

Divide eighteen by the variable r, then subtract ten.

4. $3(4-1)$

Subtract one from four. Then, multiply the answer (or difference) by three.

5. $(50 + 10) \div 2$

Divide the sum of fifty plus ten by two.

6. $5^2 - 5$

Find the value of five squared, then subtract 5.

7. $5 + 2 \times 7 - 1$

Add five to the product of 2 and 7, then subtract 1.

Answer Sheet

Name _____

Date _____

ANSWERS Write Equations: What Equals What?

Equations are number sentences with equal signs. They show how two quantities are equal. One way of thinking about equations is that they are two expressions that have the same value and are joined by an equal sign.

$5 + 2 = 7$ is an equation The value of both sides is 7.

But so is this:

$5^2 (10-5) = 25 \times 5$ The value of both sides is 125.

and this:

$10(5-2) + 1 = 11 + 20$ The value of both sides is 31.

In this worksheet you will be given an expression and asked to write another expression of equal value to create an equation. Try to use multiplication, division, and exponents whenever possible. Get creative! Think about all the ways you can make a 1 by just subtracting one number from another, such as $9 - 8$.

Hint: First evaluate the expression. Then, find another way to write that number.

- $10 \times 3 + 5 =$ POSSIBLE ANSWERS: 7×5 OR $5^2 + 10$
- $10^2 + 1 =$ POSSIBLE ANSWERS: $5 \times 20 + 1$, $5(4 \times 5) + 1$, $5 \times 20 + (9-8)$
- $50 / 2 + 3 =$ POSSIBLE ANSWERS: $100 / 4 + 3$, $5^2 + 3$
- $10 \times 10 \times 10 + 30 =$ POSSIBLE ANSWERS $10^3 + 3(9 + 1)$
- $75 \times 2 =$ POSSIBLE ANSWERS 10×15 , $10^2 + 2 \times 5^2$

Answer Sheet

Name _____

Date _____

ANSWERS

Understanding Equations: Find the Missing Operation

Now that you understand how to make both sides of an equation equal, try this exercise. Add the operation symbols: addition (+), subtraction (-), multiplication (x), or division (÷) to complete the equation.



$$(20 \text{ } \ominus \text{ } 12) + 7 = 15$$

$$(31 \text{ } \oplus \text{ } 3) - 5 = 29$$

$$(4 \text{ } \otimes \text{ } 18) + 8 = 80$$

$$(9 \text{ } \div \text{ } 9) + 9 = 10$$

$$(14 \text{ } \div \text{ } 2) + 5 = 12$$

$$(7 \text{ } \oplus \text{ } 21) - 4 = 24$$

$$(14 \text{ } \otimes \text{ } 6) + 6 = 90$$

$$(22 \text{ } \div \text{ } 11) + 9 = 11$$

$$(12 \text{ } \otimes \text{ } 2) - 5 = 19$$

$$(15 \text{ } \otimes \text{ } 3) + 7 = 52$$

$$(8 \text{ } \otimes \text{ } 4) - 5 = 27$$

$$(6 \text{ } \oplus \text{ } 15) + 6 = 27$$

Answer Sheet

Name _____

Date _____

Solving Equations Using Variables

ANSWERS

Equations can be used to find the value of variables. Simple equations can be solved using mental math.

Example: $22 - y = 20$

What number would you use to replace y that would make the equation true? If you answered 2, you would be correct.

$$22 - 2 = 20$$

In the following simple equations, you will be using mental math to find the value of the variables.

1. $3 \times y = 30$

$y = \underline{10}$

2. $5 + 1 \times n = 36$

$n = \underline{6}$

3. $2^2 - r = 0$

$r = \underline{4}$

4. $3^3 - x = 7$

$x = \underline{20}$

5. $4 \times 2 \times n = 32$

$n = \underline{4}$

6. $n - 30 = 55$

$n = \underline{85}$

7. $8x = 64$

$x = \underline{8}$

8. $45 \div p = 5$

$p = \underline{9}$

Try these challenge equations. First, find the value of the expression that doesn't contain a variable.

9. $20 + y = 5^3 + 2$

$y = \underline{7}$

10. $12 \times n + 10 = 12^2 + (2 \times 5)$

$n = \underline{12}$