

Project 20391EZ: Shop-Made Lathe Chuck



Spigot chucks support blanks for a variety of turning projects, but many facilities don't have enough spigot chucks for all the students. One way to fix this problem is to have students make their own. It's easy to make, and the only cost involved other than the wood is the hose clamp.

Shop-Made Lathe Chuck Step-by-Step Instructions

1. Start with a 3-1/2" x 3-1/2" x 3-1/2" block of hard maple (**Figure 1**).
2. Use a band saw to cut the corners off, thereby producing a rough cylinder 3-1/2" in diameter with the grain running end to end.
3. Drill pilot holes and use #12 sheet metal screws about 1-1/4" long (**Figure 2**) to attach the block to your faceplate (the smaller the faceplate, the better).
4. Mount the piece on the lathe.
5. Bring the tailstock with a live center up for extra support.
6. Position the tool rest parallel to the workpieces.
7. Use a roughing gouge to true the block.
8. Use a square scraper to reduce the right end of the cylinder to 1-3/4" diameter and approximately 1" long (**Figure 3**).
9. Remove the tailstock.
10. Reposition the tool rest in the front of the blank at a right angle to the axis of the lathe.
11. Use a 3/8" spindle gouge to true up the face of the blank with a light, shearing cut.
12. Place the point of the spindle gouge at the center of the blank to begin hollowing the center.
13. Push the gouge in to produce a hole 1" deep.
14. Withdraw the tool.

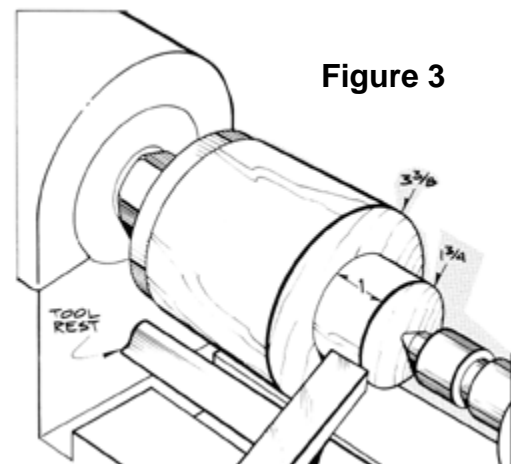
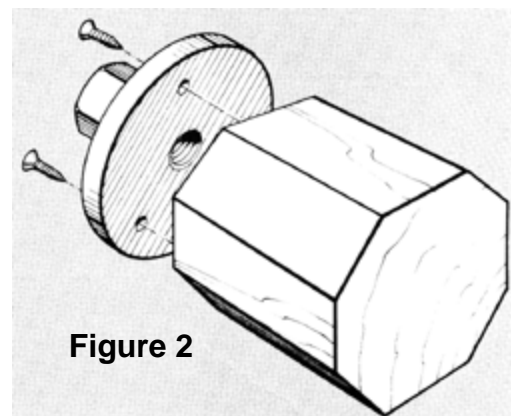
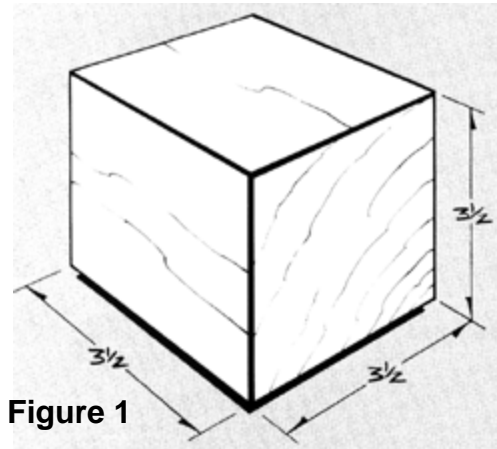

15. Proceed to hollow the opening with the same gouge, being sure to leave the walls about 1/8" thick and parallel to the outside (**Figure 4**).
16. Use a scraper to true up.
17. Remove the piece from the lathe.
18. Clamp it upright in a bench vise.
19. Use dividers to make eight equal segments on the top of the rim.
20. Use a backsaw and, being sure to stay straight up and down, make a cut down each mark to the shoulder of your chuck, creating flexible fingers (**Figure 5**).
21. Use 80-grit sandpaper to clean up the interior.
22. Slide on the hose clamp.
23. Cut the excess metal from the hose clamp.
24. Position the clamp so it will not catch on anything.

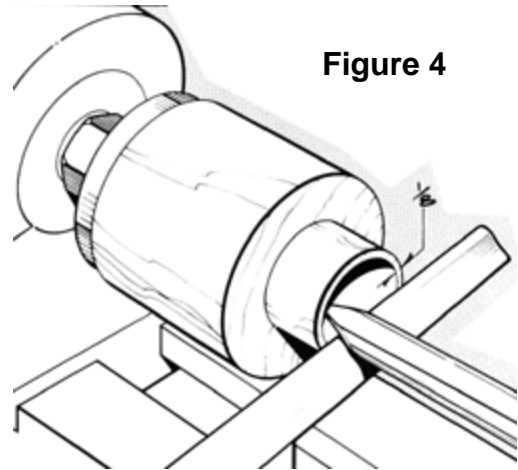

Figure 4

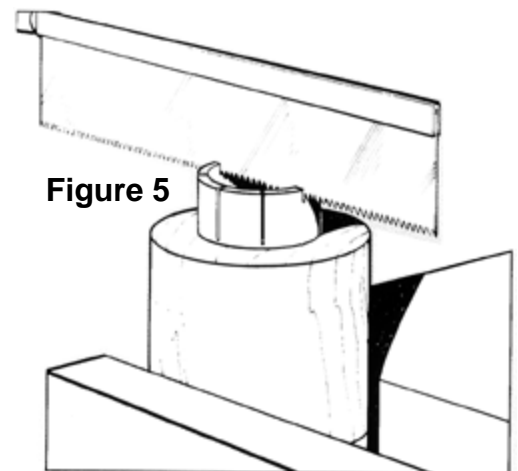

Figure 5

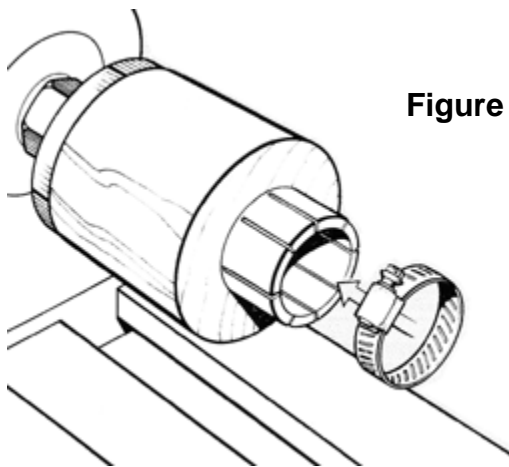

Figure 6

The tenons on your turning pieces should be approximately 1/2" long and sized accurately to fit your chuck. If they are too large, you could break the flexible fingers; too small and you will not be able to grip the

tenon and hold your stock for turning. Tighten the clamp and test the fit before turning. If you can still twist the blank in the chuck, remove it and rub chalk around the tenon to provide enough friction to keep it from spinning.

For added safety, once the turning piece is mounted, you can wrap several layers of duct tape around the hose clamp to avoid catch your knuckles.