

Pocket Hole Jig Plans



The pocket hole joint is one of the easiest joints to make. This joint is much faster and simpler than dowel joints because you only drill the hole in one of the pieces you need to join. Just apply some glue, clamp the pieces together and insert the screw. The screw stays in the joint and serves as both a dowel pin and permanent clamp. Also, you can use ready made plugs to hide the holes if the surface is to be visible.

Now you can make pocket holes on your drill press. Pocket holes are normally drilled with an electric hand drill and a special step drill bit which cuts the larger (3/8") diameter hole for the screw head and the smaller pilot hole in one pass. This jig makes it possible to use either a regular pocket hole step drill or forstner bits. For instance, you can use a 1/4" forstner bit for the outer hole and a 1/8" twist drill for the inner hole to make pocket holes for smaller screws. An added benefit is the extremely clean cut you get from forstner bits.

If you want to plug your pocket holes, you can use a set of tenon/plug cutters and this jig to make your own plugs. Just cut a row of plugs in a piece of matching wood and use your table saw to cut the bottom of the plugs from the surrounding wood.

Note: The drill press pocket hole jig is great for medium to small size work pieces. For larger work pieces, you'll still need a traditional pocket hole jig.

Table of Contents

Please read and follow all tool manufacturers safety and operating instructions before operating equipment. Always wear eye and hearing protection.

| | |
|---|---|
| Materials List | 1 |
| Pocket Hole Jig Parts Drawings (A) | 2 |
| Pocket Hole Jig Parts Drawings (B) | 3 |
| Pocket Hole Jig Assembly Instructions (A) | 4 |
| Pocket Hole Jig Assembly Instructions (B) | 4 |

Introduction

I hope you will find our Drill Press Pocket Hole Jig to be a rewarding and useful project. The base is made of either 3/4" or 1/2" material. The front is made of 3/4" material because it requires 1/2" deep slots for the T-Track. The gussets, work support, and stiffener are made of 3/4" stock. You'll need one 11 1/2" and one 7 1/2" strip of T-Track. You'll also need some knobs, clamps, and T-Track bolts.

This project has two 5/16" mounting holes that are spaced so it can be mounted to the drill press table for which free plans are also offered on BobsPlans.com. It was originally designed for use in making spokes for the 14" wagon wheel for which we offer plans. But it comes in handy any time there is a need to hold a small piece of stock for either drilling or sawing. Examples of how to use this jig can be seen at www.bobsplans.com.

For clean and accurate cuts, the work piece must be securely clamped to the jig. I highly recommend you glue sandpaper to the surfaces of the face of this jig. The sandpaper greatly increases the holding power of the clamps.

Sources for the T-Track and clamps you'll need are provided on the sponsor's page.

Materials List

Page 1

Pocket Hole Jig Materials List

| Qty | Item Name | Size | Material |
|------------|--------------------|------------------|--------------------|
| 1 | Base | 12" X 10" | 1/2" or 3/4" Stock |
| 1 | Front | 11 1/2" X 8" | 3/4" Stock |
| 1 | Work Piece Support | 11 1/2" X 1 1/2" | 3/4" Stock |
| 1 | Stiffener | 7 1/2" X 1" | 3/4" Stock |
| 2 | Gussets | 3 1/2" X 2" | 3/4" Stock |
| 1 | T-Track | 11 1/2" | Aluminum T-Track |
| 2 | T-Track | 7 1/2" | Aluminum T-Track |
| 2 | T-Track Bolts | Assorted | |
| | Toggle Clamps | | |
| | Hold Down Clamps | | |
| | Stop Blocks | | |

Pocket Hole Jig Parts Drawings (A)

Page 2

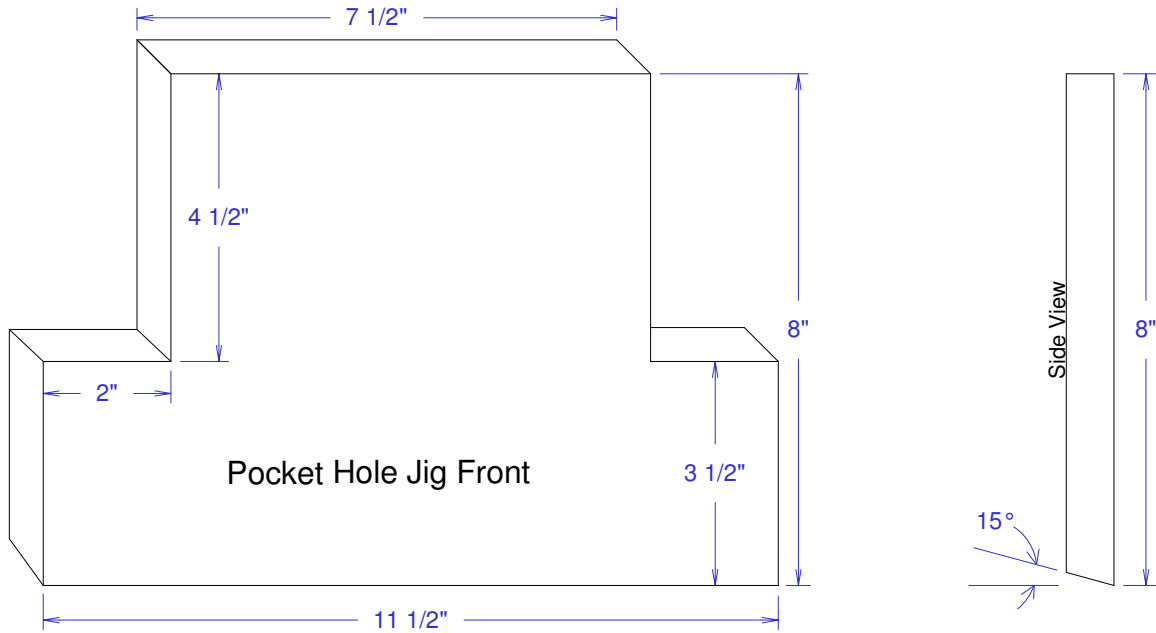

Cut the pocket hole jig front from 3/4" stock (3/4" plywood will work fine). The 15° angle on the bottom is necessary because the front must tilt back by 15° so it holds the work piece at the correct angle.

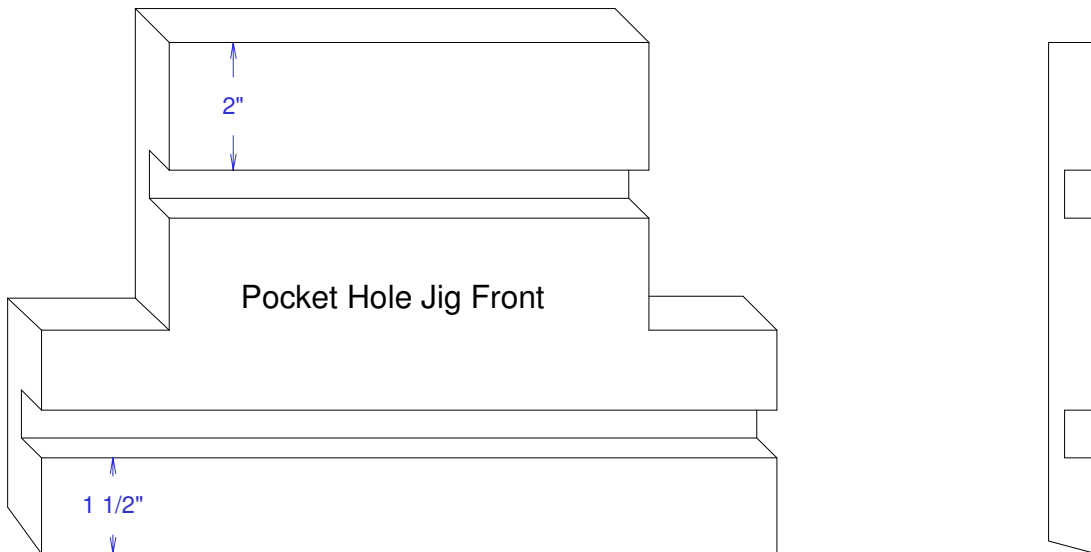

Cut two 3/4" wide by 1/2" deep slots for the T-Track as shown above. This only leaves 1/4" material thickness for the T-Track screws but the screws will be aligned with the gussets and stiffeners when the jig is assembled.

Pocket Hole Jig Parts Drawings (B)

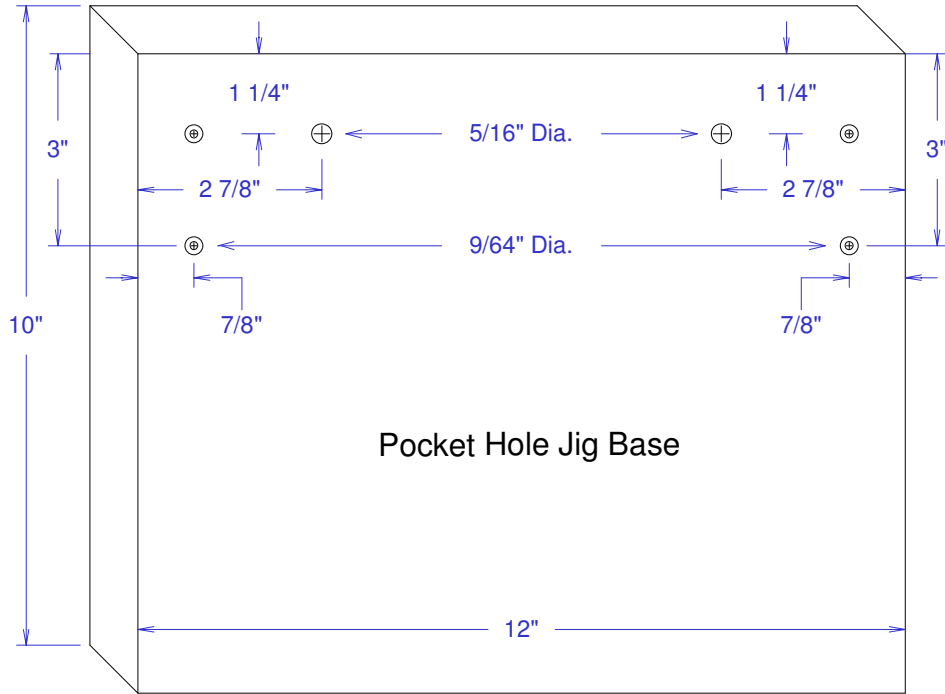

For the base, either 1/2" or 3/4" stock will work fine. Drill the holes as shown above. The four 9/64" holes are for the # 6 flat head screws that secure the gussets. They should be countersunk on the underside of the base.

The two 5/16" holes are for T-Track bolts. Since this jig is designed to be mounted on the drill press table for which we also offer free plans, these holes should have 6 1/4" between centers. If you won't be using the pocket hole jig with our drill press table, the holes should be spaced based on the way the jig will be secured to your drill press table.

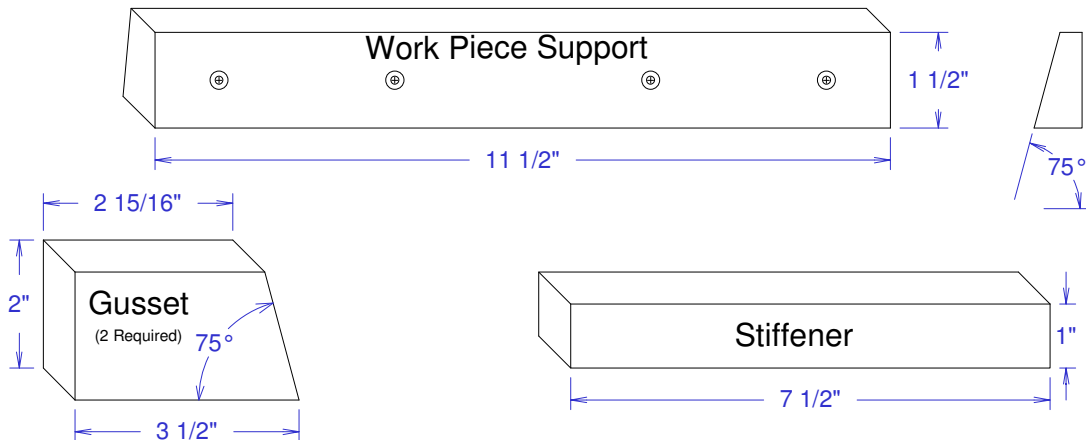

The Work Piece Support, Gussets and Stiffener are made from 3/4" stock. The Work Piece Support must have a 75° angle as shown in the end view. You can get the proper angle by setting your table saw blade to 15°. (90° - 15° = 75°.)

Tenon Jig Assembly Instructions (A)

Page 4

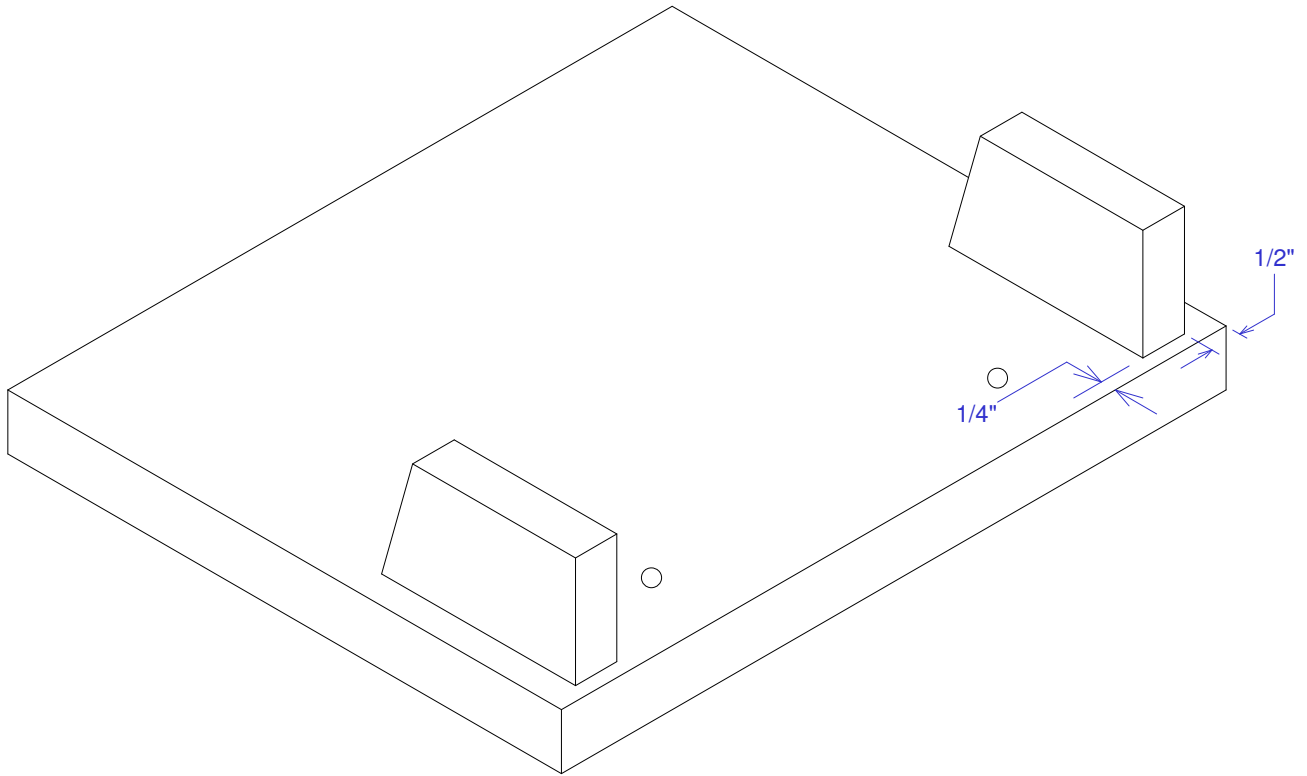

Attach the Gussets to the base as shown above using 1 1/2" # 6 screws.

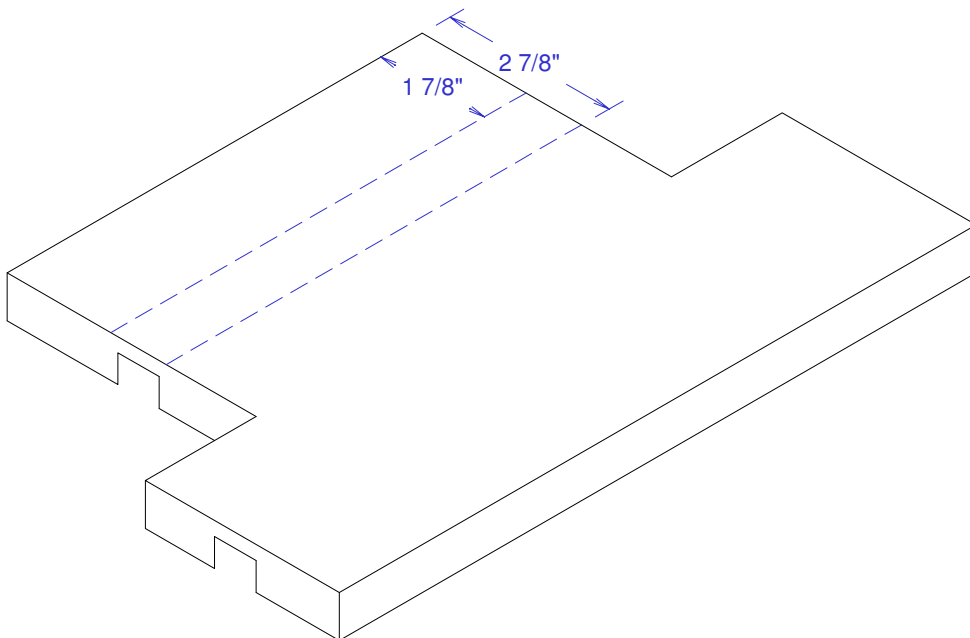

Mark the position of the Stiffener on the backside of the Front section. It should be centered over the slot for the upper T-Track.

Tenon Jig Assembly Instructions (B)

Page 5

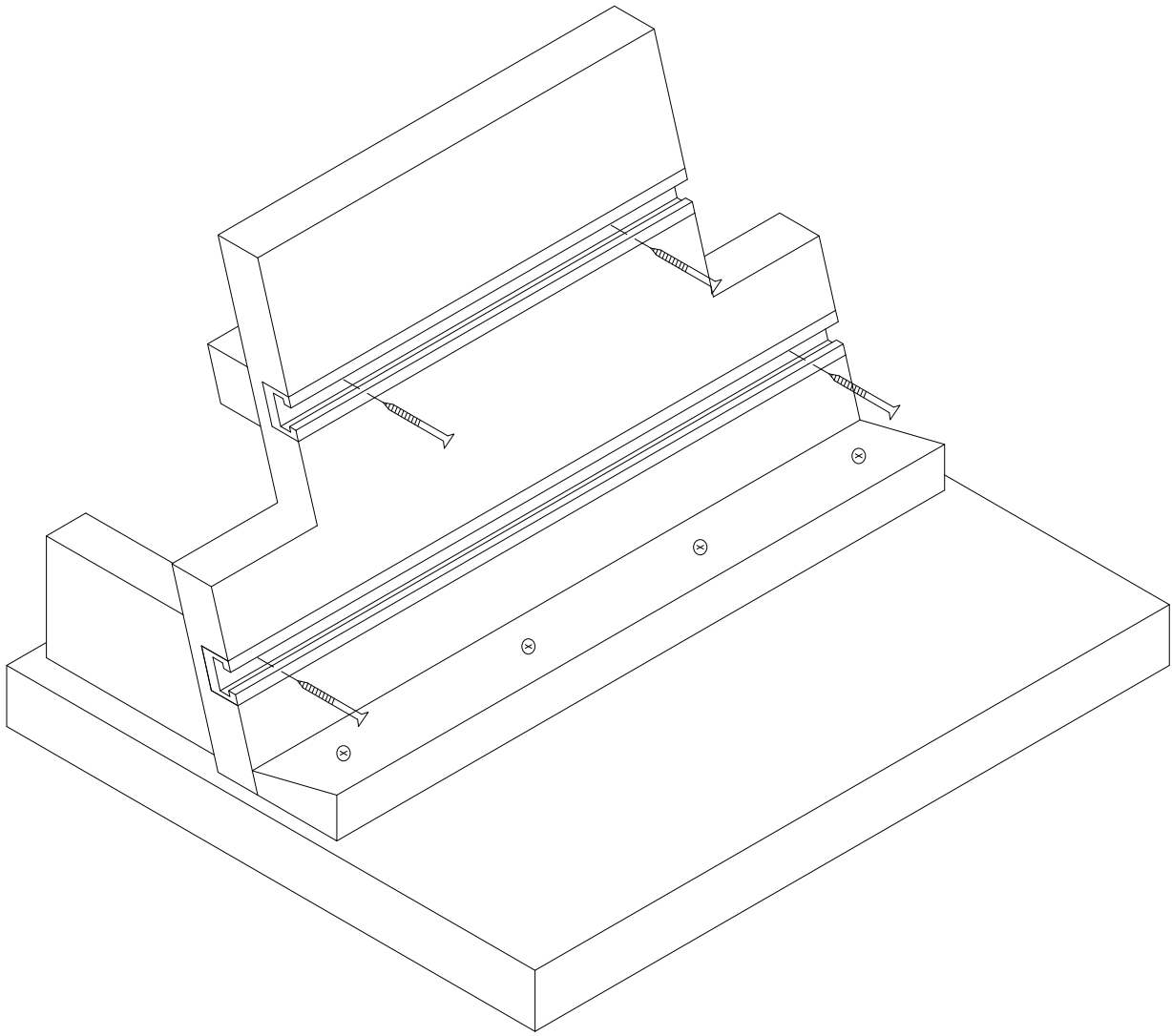

Drill and countersink a 9/64" hole 5/8" from each end of the long piece of T-Track and 1 1/4" from each end of the short T-Track. Then position the T-Track, Front, and Stiffener as shown above. Secure the Front to the Gussets with 1 inch # 6 flathead screws through the lower T-Track. Apply some glue and clamp the Stiffener behind the Front section (centered behind the Upper T-Track) and secure the upper T-Track with 1 inch # 6 flathead screws.

Next, Install the Work Piece Support with four 3/4 inch # 6 screws. The end screws should be about 1 inch from each end and the middle ones about 4 1/2" from each end. Don't glue the Work Piece Support to the Base because you'll want to be able to replace it from to time.

This completes your Drill Press Pocket Hole Jig.