

SHAKER STEP-STOOL

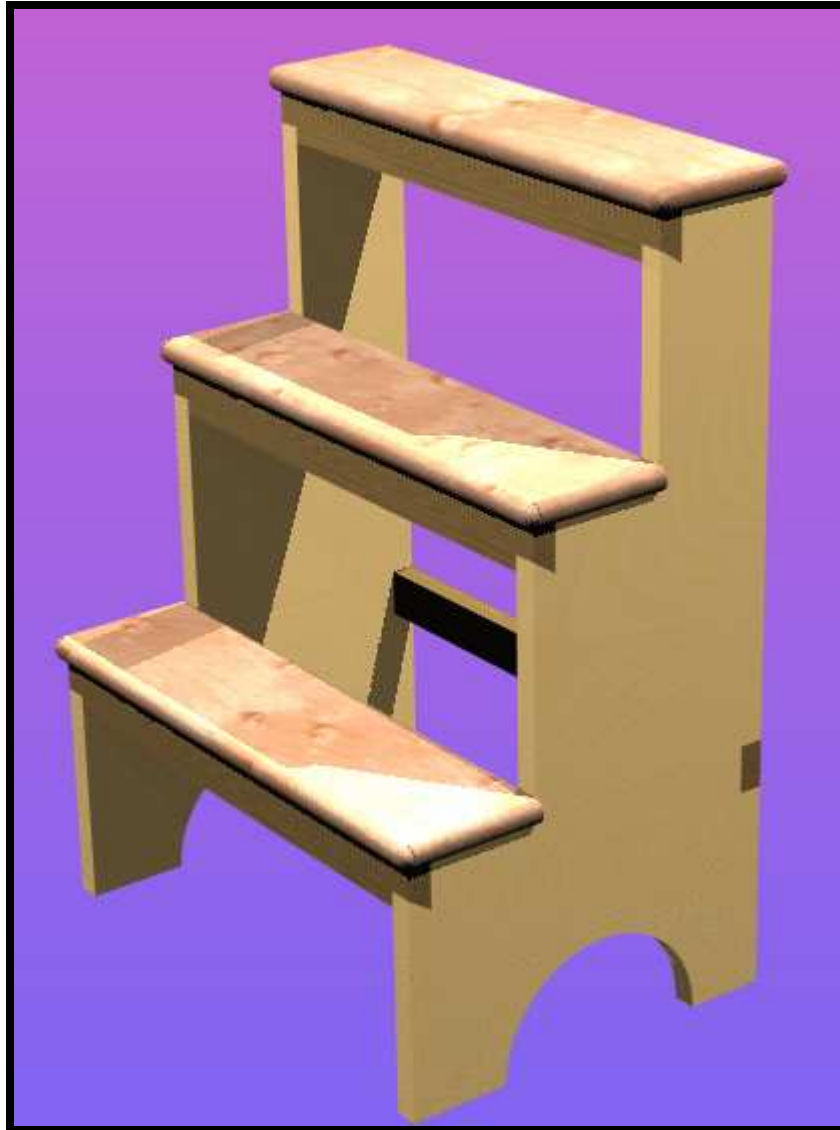

This tutorial is the design of a shaker style step stool. It consists of sides, steps, back cross piece and front dovetail cross pieces. Several items such as the sides and

bottom and middle steps need only be designed once since they will be used more than once in the final assembly.

When you open Pro/DESKTOP, set the Options, Units to inches. It is expected that you already know how to move between orthographic and pictorial views and have a reasonable amount of skill in using the mouse.

A complete dimensioned drawing of this project is presented below. Refer to this drawing for accurate numerical data while executing the design.

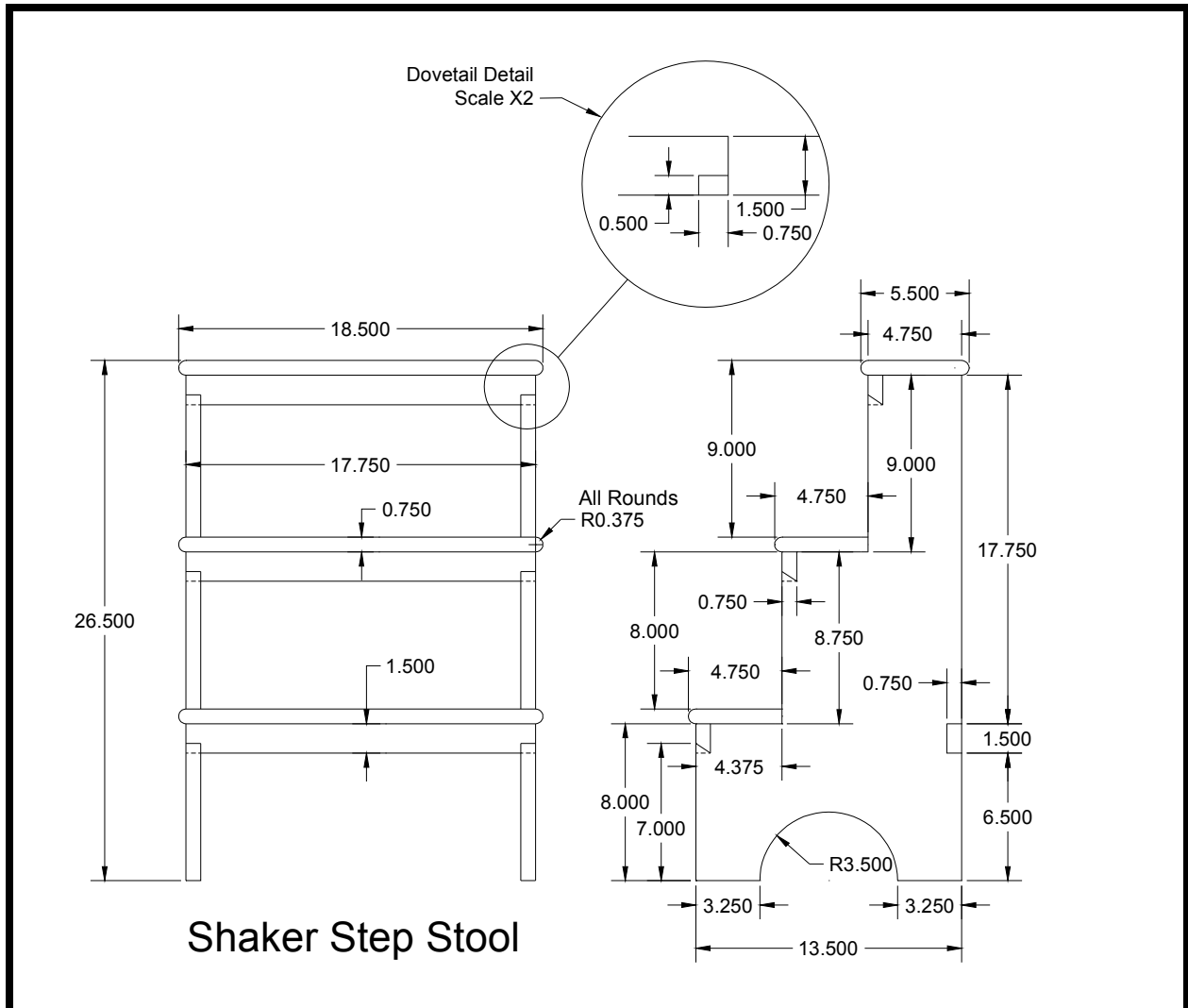

Dimensioned Drawing for Step Stool

Knowledge or information you should know prior to beginning this tutorial:

- ★ Navigate in Windows
- ★ Create, save, rename and delete folders and files
- ★ Mouse commands - right and left click and mouse wheel
- ★ Basic Pro/DESKTOP sketching tools - lines, circles etc.
- ★ Pro/D Workplanes and sketches.

What you should learn from completing this tutorial:

- ★ Create sketches
- ★ Draw valid profiles
- ★ Extrude profiles
- ★ Rounding Edges
- ★ Assembly
- ★ Alignment, Centering Axis and Mating

1. Open a new Pro/Desktop Design (CTRL +N)
2. Use the dimensions in figure 1 to create a valid profile. Length is 17.75" and width is 1.5"
3. Select Extrude Profile and extrude the profile 0.75" above the workplane.

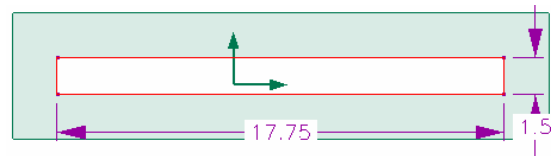

Figure 1. Dimensions of back cross piece

4. The resulting solid object should look like figure 2. Save the design and name it Back Cross Piece

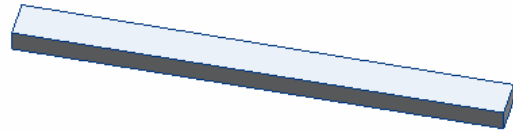

Figure 2. Finished Back Cross Piece

5. Open a new design (Ctrl + N)
6. Create a valid profile of the side of the step stool. A valid profile should look like figure 3. See page 2 for dimensions. Notice that the bottom and right side lines have a Fixed constraint (triangle). (Dimensions have been removed for clarity)
7. When you have a valid (filled) profile, select Extrude Profile and extrude a distance of 0.75" above the workplane.
8. Save the resultant profile and name it Side Piece. It should look like figure 4

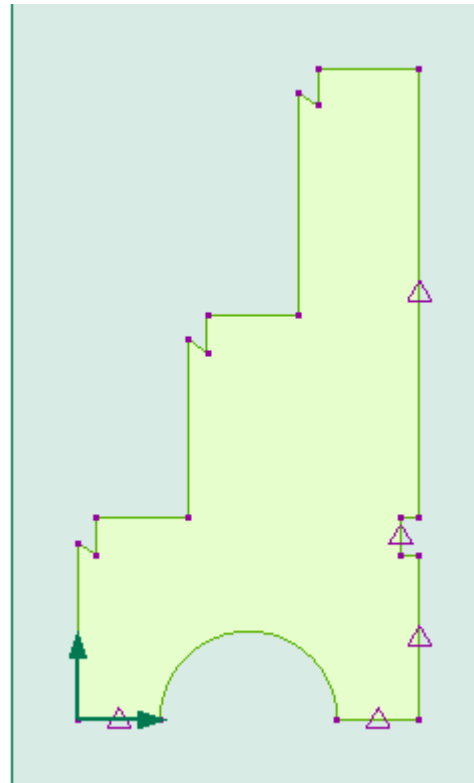

Figure 3. Valid Side Profile

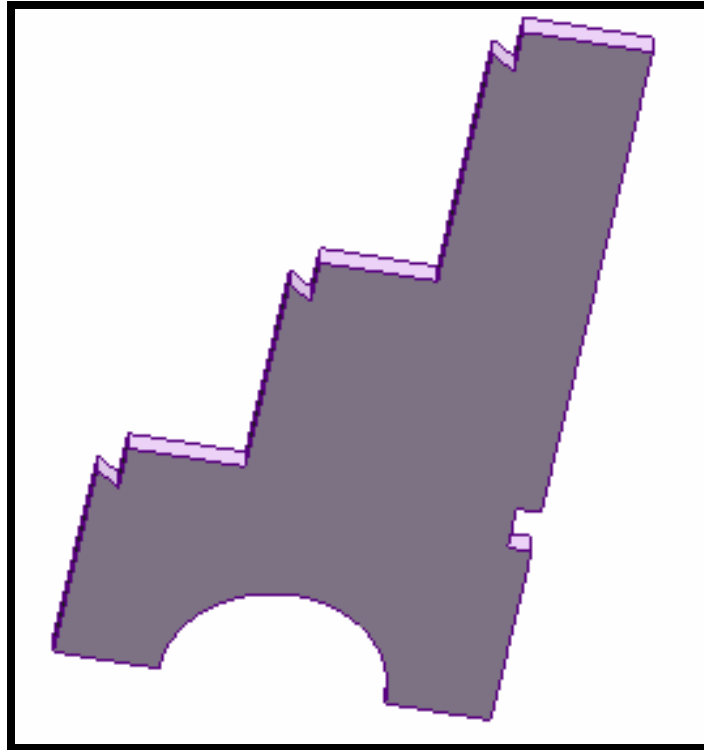

Figure 4. Finished Side Piece

9. Open a new design (Ctrl + N)
10. Draw a rectangle 5.5" long and 0.75" high as shown in figure 4
11. Select Extrude Profile and extrude the profile 18.5" above the workplane. Rotate the view so that it is similar to figure 5.

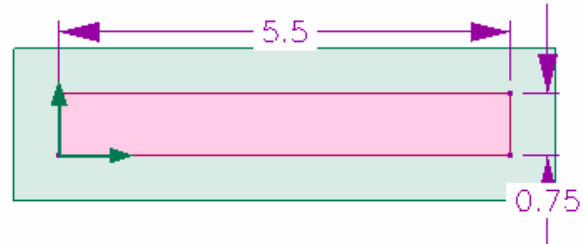

Figure 4. Extruded Top Step

12. Use Face Selection  to select either the Top or Bottom face. The face will turn red.
13. With the face selected, right click and select Round Edges.



Figure 5. Extruded Top Step

14. Figure 6 shows the top face selected and the Round Edges dialog box correctly filled for a 0.375" round. Notice the yellow trial view in the background. Click OK to complete the rounds.

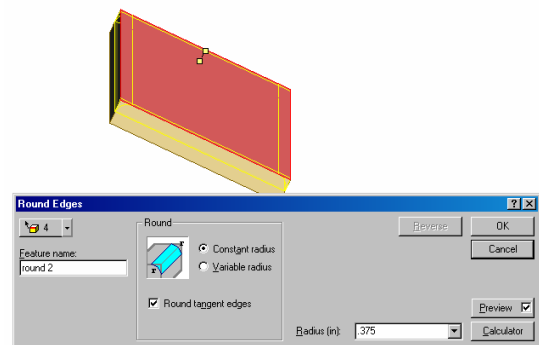

Figure 6. Top Face selected for rounding.

15. Rotate the image and select the bottom face. Right Click and select Round Edges. Set the radius to 0.375" and click OK to complete the round.
16. The image should look like figure 7. Save it and name it Top Step.

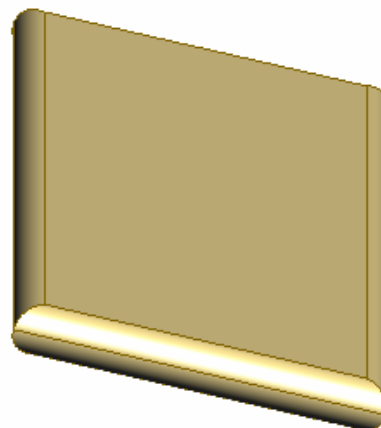

Figure 7. Completed Top Step.

17. Open a new design (Ctrl + N)
18. Draw a valid profile according to the dimensions given on page 2 and figure 8.
19. Once you have a valid (filled) profile, select Extrude Profile and extrude the profile 0.75" above the workplane.

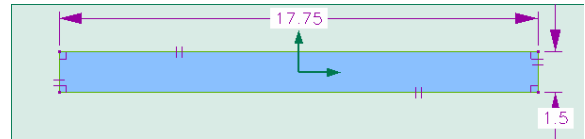

Figure 8. Dimensions for Front Dovetail Piece.

20. Use face selection to select one end face of the extrusion. It will turn red. Right Click and select New Sketch. Name it Dovetail Notch 1.
21. Draw the valid notch triangle for the notch as shown in figure 9.

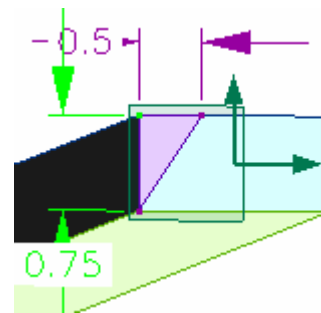

Figure 9. Dovetail notch triangle profile.

22. With the valid profile filled, select Extrude Profile and extrude the profile. You must subtract material a distance of 0.75" below the workplane.

23. Figure 10 shows the completed notch with material removed.

24. Repeat this process by selecting the other end of the part, create a new sketch (Dovetail Notch 2) and remove material for the Dovetail.

Figure 11 shows the finished Front Dovetail piece.

25. Save this part and name it Front Dovetail Piece.

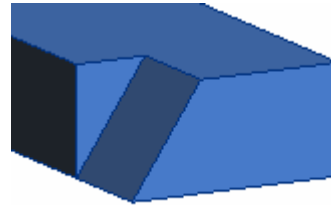

Figure 10. Remove material for Dovetail.

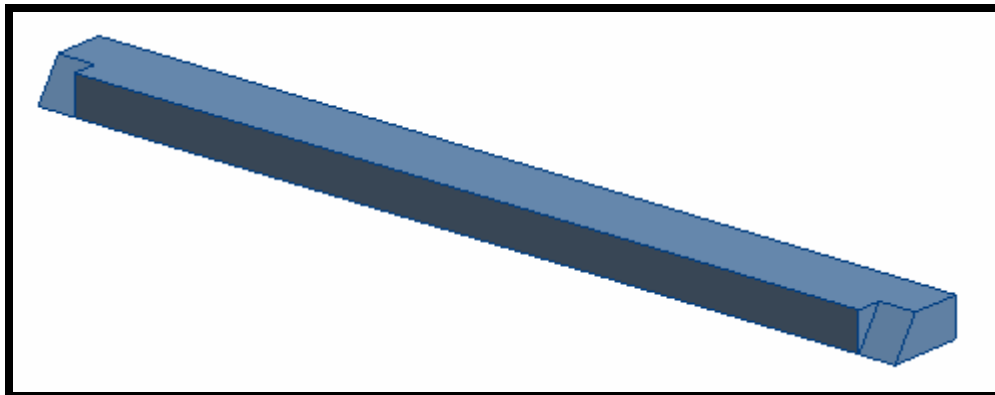

Figure 11. Finished Front Dovetail Piece

26. Start a new design (Ctrl + N)

27. Draw the profile shown in figure

12. The two radii are 0.375"

28. When you have a valid profile, select Extrude Profile and extrude a distance of 0.75" above the workplane.

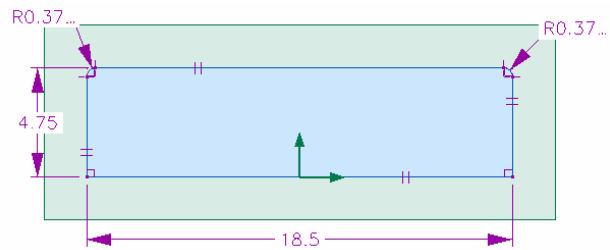

Figure 12. Bottom and Middle Step Profile.

29. Select front and side edges (do not select the back edge), right click and round them to 0.375". The back face remains unrounded to fit flush in the final assembly. Figure 13 shows the finished step. Save it and name it Bottom and Middle Step.

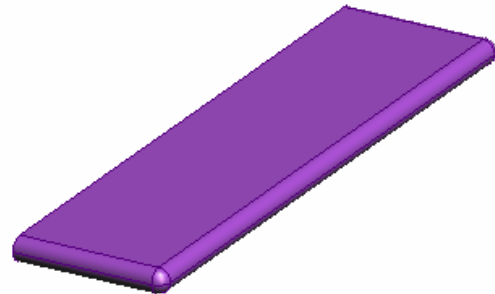

Figure 13. Finished Bottom and Middle Step.

30. Start a new design (Ctrl + N)

31. Under Assembly, select Add Component. Select the Side Piece. When it is loaded and still selected (red), move it to the left then under Assembly select Fix Component. This will fix the part so that it will not move while attaching other parts. See fig. 14.



Figure 14. First part added and Fixed.

32. In a similar fashion, Add Component parts until you have all the parts necessary to assemble the Step Stool. Figure 15 shows all the parts ready for assembly. Your parts may not be in the same place as the illustration but each can be selected (part selection) and moved. Move each duplicate part when it is added so they will not overlay each other.

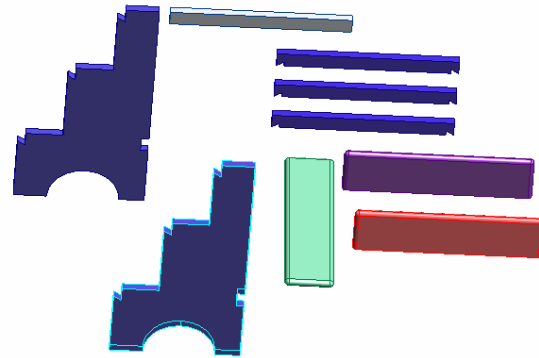



Figure 15. All Components Added ready for Assembly.

33. Use Edge Selection  and select the top edge of the notch in the back of the fixed side piece and the top edge of the back cross piece as shown by arrows in figure 16. Hold the shift key down to select more than one edge

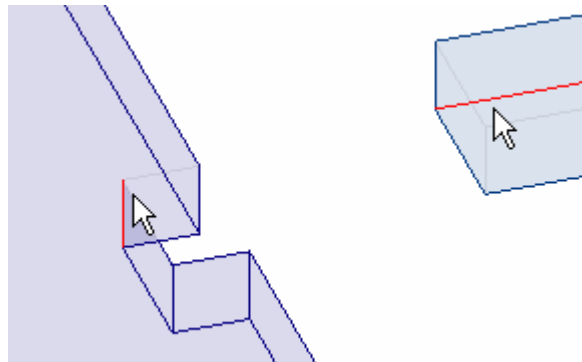

Figure 16. Edges Selected

34. With the two edges selected (red), right click and select Center Axis. The cross piece will center with the notch. Use part selection to select the cross piece and move it so it is similar to figure 17. It will slide in the constraint plane. Be sure to move the cross piece so that the left end is near the notch.

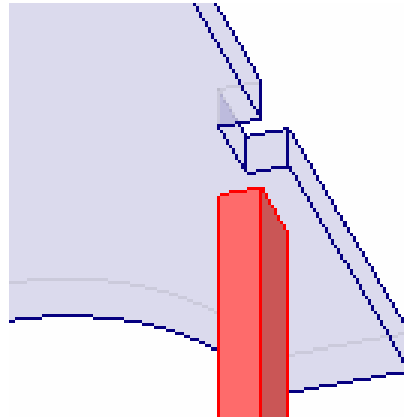

Figure 17. Cross Piece moved prior to mating.

35. The Center constraint applied to the cross piece may need to be suppressed so that another constraint can be applied. To do this, select Components in the browser, then highlight Back Cross Piece. See figure 18. Notice at the bottom of the browser a Constraint tree will be visible. Right click on any constraint and select Suppress. Now Right Click on any remaining constraints and select Suppress. This will suppress all constraints and allow you to apply another constraint.

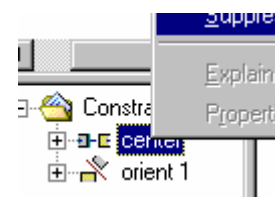

Figure 18. Suppressing Constraints.

36. Use Edge selection to select the two edges shown in figure 18.

37. Right Click and select Center Axis. The cross piece will align with the notch.

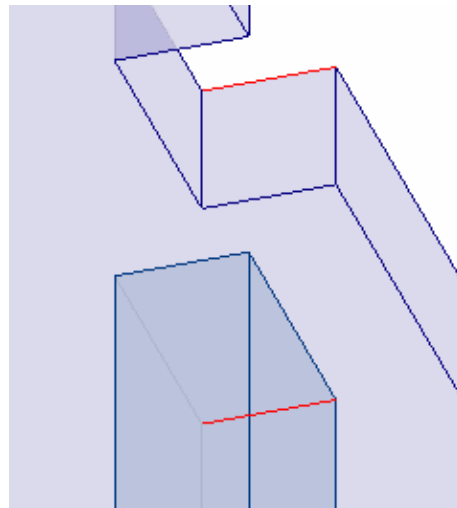

Figure 18. Edges Selected prior to Centering Axis
(Selected Edges in Red)

38. Move the left side piece so it is oriented similar to figure 19. Turn on the transparent view mode for easier viewing if desired.

39. Zoom in on the end of the cross piece and the notch.

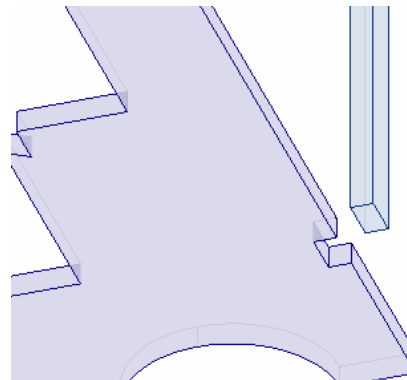

Figure 19. Orient left side piece.

40. Select the edges shown by the arrows in figure 20.

41. Right click and select Center Axis.
The cross piece should align with the side piece notch.

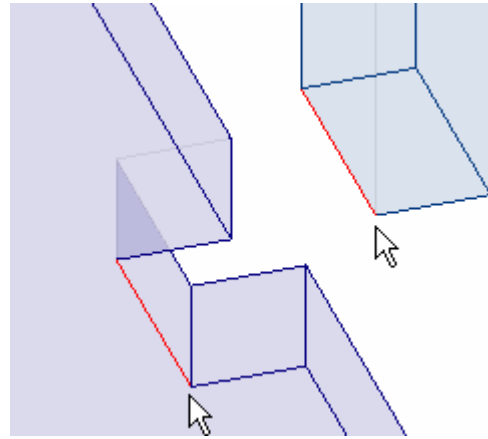

Figure 20. Edges Selected for Centering Axis.

42. Figure 21 shows what the assembly should look like at this point.

43. Select one of the dovetail cross pieces and orient it near the top of one side.

44. Using Center Axis and Mating constraints, select edges and faces and constrain the dovetail front piece to one side piece. You may need to suppress constraints if you get an error message indicating that a new constraint will over constrain the part.

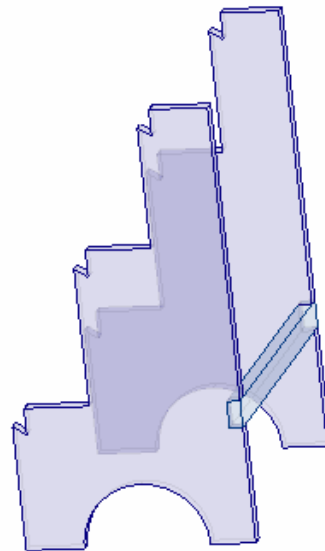

Figure 21. Assembly with sides and back piece.

45. Figure 22 shows the top dovetail cross piece installed.

46. Using the same procedure, install the middle and bottom front dovetail cross pieces.

47. Figure 23 shows the assembly with all cross pieces installed.

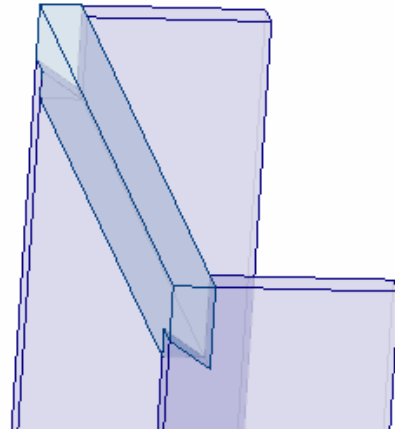

Figure 22. Top Dovetail Piece installed.

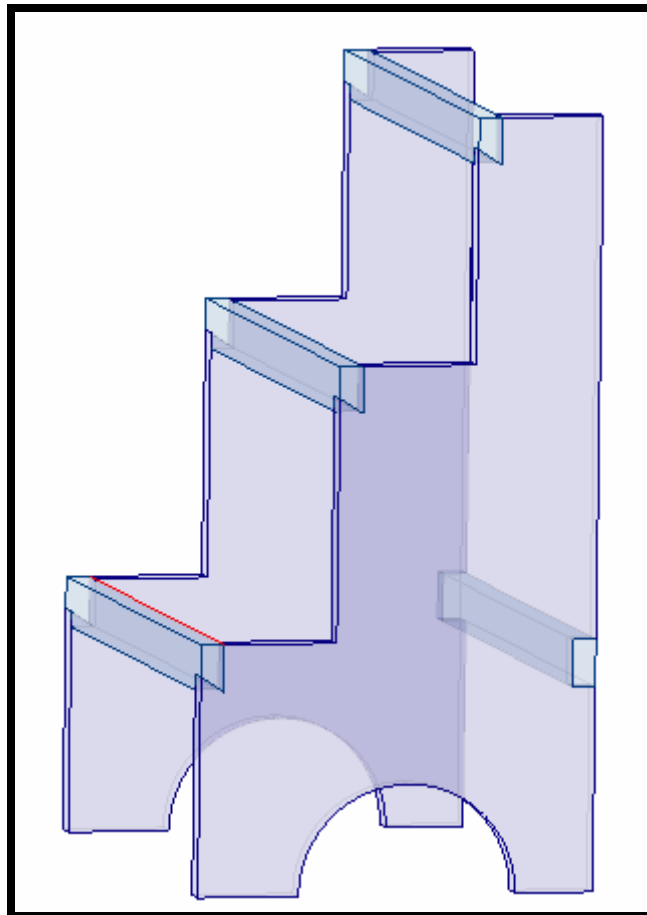

Figure 23. Assembly with all cross pieces installed.

48. Select the top step and orient it near the top of the sides. Use edge select, select one of the outside edges of the top and a corresponding outside edge of the step end. Do not select the outside of the round. Use Center Axis to constrain the step to both directions so the step fits exactly on top of the sides. Figure 24 shows the step installed.

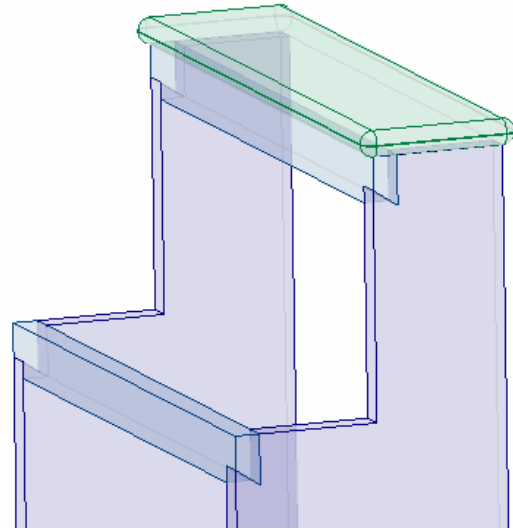

Figure 24. Top step installed.

49. In a similar fashion, install the middle and bottom steps. Use edge and face selection and constraints such as Center Axis and Mating. You may need to suppress some constraints in order to apply new constraints.

50. Figure 25 show the completed step stool. Save it and name it Step Stool Assembly.

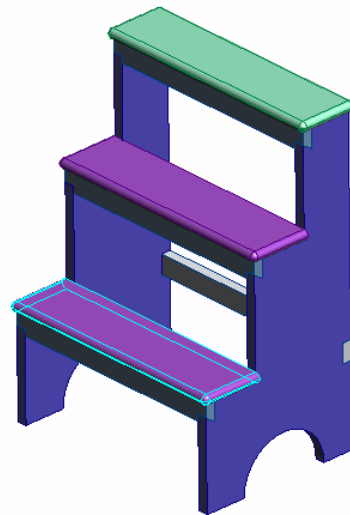

Figure 25. Completed Assembly

51. The last exercise will create an Album of this design.
52. Under File, select New then Photo Album.
53. A new window will open but there will be no image in it. If you already have the previously completed assembly design open, it can be loaded by selecting the Image drop down menu and select New Image. A dialog box will appear with the assembly design (and any other designs that are open) as in figure 26. Press OK to load the design.

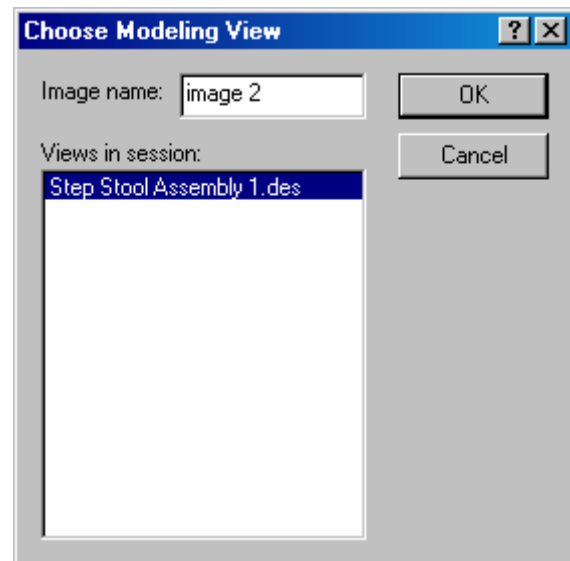

Figure 26. Choosing an Open session to load into an Album.

54. If you do not have a design open, you can browse to open the assembly drawing. It will look like figure 27.

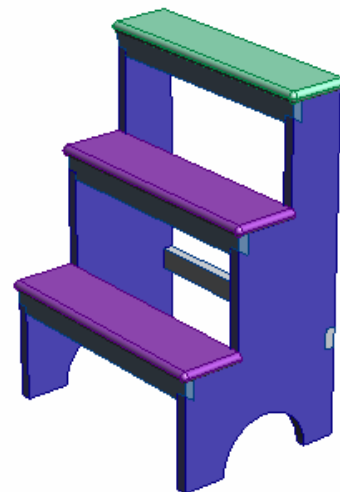



Figure 27. Assembly design loaded into Album.

55. To change material, select Materials in the browser. Click the + in front of non-metal. Notice that a number of materials are available as shown in figure 28.

56. Select Wood, varnished. Click on the bag at the left of the words and drag. When you drag over the parts in the design, the bag will turn into a material fill cursor . When the cursor is in the fill mode and the part is highlighted, release the mouse button and the part will fill.

57. You will not see the change since any change will need to be up-

dated. Notice the  update button in the menu bar. When it is green it means you need to click it to see the effect of the fill or change you have just completed.

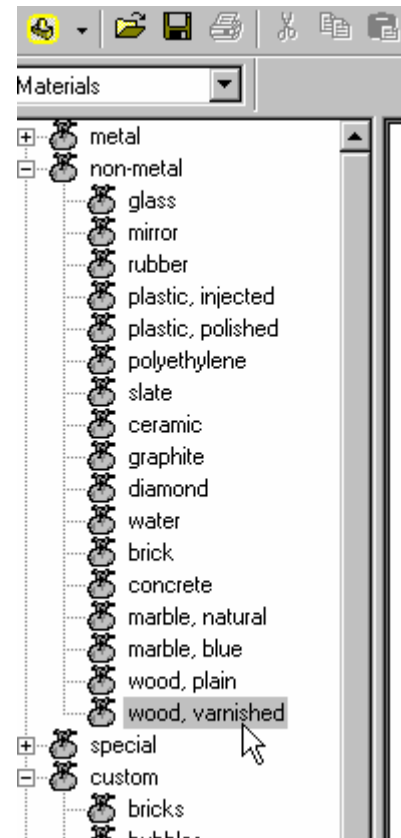

Figure 28. Selecting a fill material.

58. Select wood, varnished and drag into the design. Drag over one of the sides until it highlights then release the mouse button. Press the up-date button to see the result. It should look like figure 29.

59. Notice that both left and right sides have taken on the material characteristics. This is because we designed 1 side and all duplicates will take on the same material character.

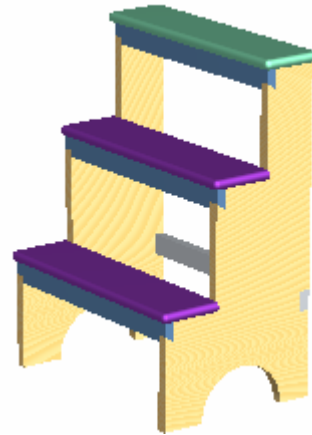

Figure 29. Varnished Wood added to sides.

60. Fill the steps with maple (under custom). You will need to fill the top step separately since it was designed as one unit.

61. Fill the dovetail cross pieces and back cross piece with wood, plain.

62. The design should now look like figure 30.



Figure 30. Step stool fill completed.

63. You can change the color of any part by highlighting it then right click. A color selection box can be used to select any desired color.

64. To change the foreground and background, select the Image drop down menu then Image Properties. A dialog box such as in figure 31 will appear. This will allow you to change lighting (Studio) or the image quality (Image).

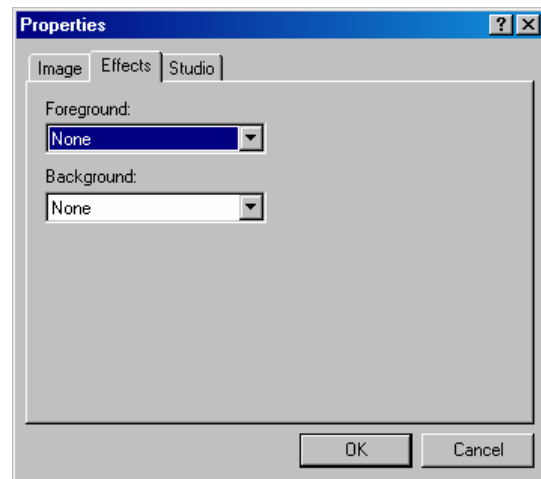

Figure 31. Image Properties.

65. Click on the Foreground selection button. This will reveal a number of possible selections such as clouds or snow.

66. Click on the Background button. Select Graduated. A new dialog box will appear that has a button for top color and bottom color.

67. Click the top color button and pick a color (I used a light blue) Click OK. See figure 32.

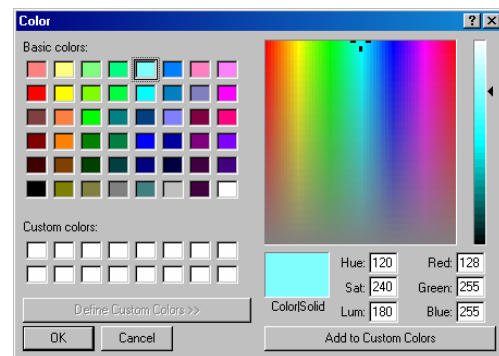

Figure 32. Picking a top color.

68. Click the bottom color button and select a color (dark blue) Click OK then click OK to get back to the design.
69. Click the up-date button and notice that the background now starts at a light blue at the top and gradually changes to dark blue at the bottom as shown in figure 33.
70. Save this album and give any name you choose.

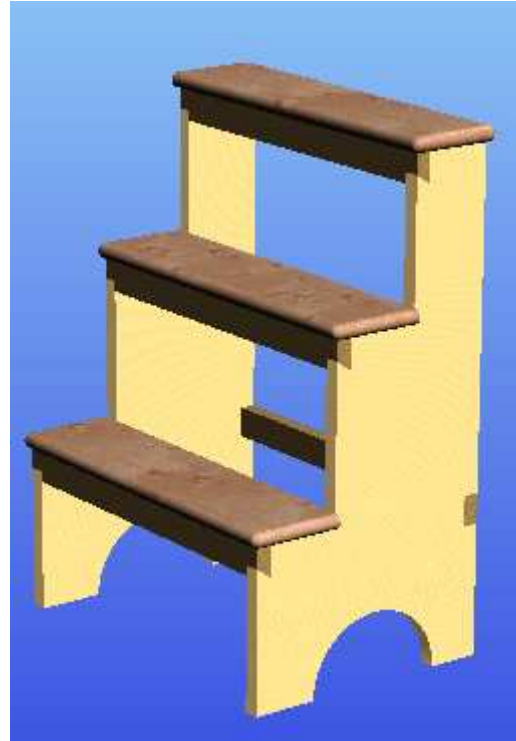

Figure 33. Graduated background.

71. You can also change the quality of the image by increasing the pixel setting.
72. Under Image properties, select Image. The dialog box in figure 34 will appear. Notice you can set the rendering quality to Presentation and change the pixel resolution to a number of high values. Figure 35 is the image after setting the values shown in figure 34.

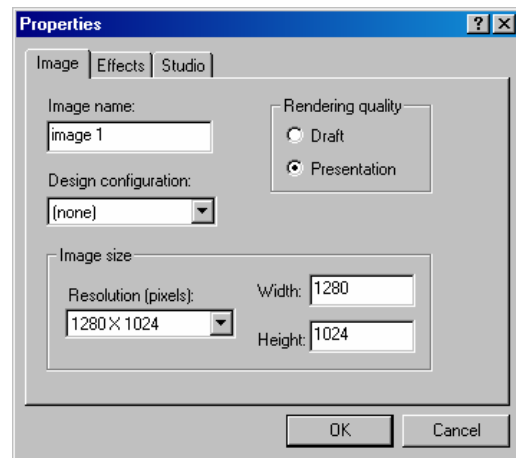

Figure 34. Setting the quality of the image.



Figure 35. High quality image.

This concludes this tutorial. You can experiment with the various colors and materials available in the Album browser. You can also import other images such as jpeg that can be used as a background. Under the File menu you can select export and save the Album file in any of several standard graphic images such as bitmap, jpeg, or TIFF. You also have the opportunity to use the image as Wallpaper.