

43 CABINET BATHROOM



Start At the Top

The first thing I needed was a moulded sink top. It measured 19" x 31" and was the starting point for the project.

My design includes what I call extended cabriole legs on the front, creating an elegant, old-fashioned look. I used sugar pine for these legs. It's a little harder than eastern white pine, but it's still easy to work with. The outline of the 1/4"-thick hardboard template I made for the leg profile is on this illustration.

Creating cabriole legs is within the reach of most woodworkers. The plans include step-by-step directions. The technique is quite straightforward but you'll need access to a bandsaw and the patience to sand the inside and outside curves that form each leg. This is where pine makes life easier than hardwood.

Once you've got two front legs and the straight back legs done, it's time to tackle the side panels. Although most bathroom cabinets are 32" tall, I went with 36". This is reflected in the materials list. To shorten this cabinet to a standard height, reduce the side stiles, door stiles and upper portion of the legs by 4".

The plans show the stiles and rails joined into a frame with #20 biscuits. The panels fit into the inside face of this frame, within 1/4"-wide x 3/8"-deep table-routed rabbets you make after the frames are dry and sanded flat.

The next step is to install the side panels, but two things must happen first. The edge of the panels needs to be routed to fit the 3/8" rabbet you routed in the frame. The four rounded corners of the frame rabbet must be squared with a sharp chisel. Secure the panel with 1/2" finishing nails or wood trim on the inside face of the side frame. This is the same design and construction process I used to build the face frame, door and drawer frames. Build these parts now. Sand them flat, then rout a round-over profile on the outer edges of the drawer face and doors.

Bring the Cabinet Together



Creative cabriole legs cut from a template refine the vanity's stance and give it a furniture-like appeal



Sillaot's trademark drawer slides function beautifully but require an eye for precise tolerances

With the side and face frames done, it's time to join them to the legs. I used screws driven into angled pocket holes. This is fast, easy and allows me to assemble the whole cabinet without waiting for glue to dry.

When the cabinet is assembled, including the two back support members, you can measure the opening for your drawer box. Mechanical slides like the kind I used require a specific drawer-to-cabinet clearance—usually 1/2" on each side. That's why you should measure your drawer opening and make changes to the drawer specs if needed. Construction variations can easily throw dimensions off 1/8"—more than

enough to make mechanical drawer slides perform poorly. The plans show how the drawer support rails provide a surface for the mechanical slides to fasten to.

I kept things simple with butt joints at all four drawer box corners. The drawer bottom fits into 1/4" x 1/4" dados in the sides, front and back. Install the drawer in its opening on the slides, then temporarily fasten the frame and panel drawer face to the drawer box with four screws driven from inside the box. Take the drawer face off for finishing.

Final Steps

Minwax pre-stain wood conditioner was used to even out the absorption of the Ipswich Pine stain. The stain was sealed under three coats of oil-based urethane. Once the finish is complete, seat the sink top on a bead of silicone applied along the top edges of the cabinet. Screws driven through the top and bottom back members and into wall studs will secure it to the wall. Hook up the plumbing and you're ready to go.

<i>For the Cabinet</i>	<i>Material</i>	<i>Size</i>	<i>Qty.</i>
Front legs	sugar pine	4" x 4" x 36"	2
Back legs	sugar pine	2" x 2" x 36"	2
Side rails	pine	3/4" x 2 1/4" x 9 3/4"	4
Side stiles	pine	3/4" x 2 1/4" x 22 1/2"	4
Side panels	pine	3/4" x 10 7/8" x 18 3/4"	2
Face frame stiles	pine	3/4" x 2 1/4" x 22 1/2"	2
Face frame top rail	pine	3/4" x 1 1/4" x 20 5/8"	1
Face frame centre rail	pine	3/4" x 2" x 20 5/8"	1
Face frame bottom rail	pine	3/4" x 1 1/2" x 20 5/8"	1
Drawer supports	pine	3/4" x 2 3/4" x 16 1/8"	2
Top back cross member	pine	3/4" x 4 1/2" x 25 1/4"	
Bottom back cross member	pine	3/4" x 2" x 25 1/4"	1
Sink top	molded acrylic	19" x 31"	1
<i>For the Doors</i>			
Door rails	pine	3/4" x 1 3/4" x 7"	4
Door stiles	pine	3/4" x 1 3/4" x 14 1/2"	4
Door panels	redwood	3/4" x 7 5/8" x 11 5/8"	2
Door spacer	pine	1/4" x 2" x 13 3/8"	1
<i>For the Drawers</i>			
Drawer box fronts	birch-veneer ply	1/2" x 4" x 18 5/8"	2
Drawer box sides	birch-veneer ply	1/2" x 4" x 16"	2
Drawer bottoms	birch-veneer ply	1/4" x 15 1/2" x 19 1/4"	1
Drawer face rails	pine	3/4" x 1 3/4" x 18 1/4"	2
Drawer face stiles	pine	3/4" x 1 3/4" x 5 1/2"	1
Drawer face panel	redwood	3/4" x 2 5/8" x 19"	1
Drawer slides	full-extension	16"-long	2
Drawer/door knobs	white porcelain	1 1/8" dia.	4

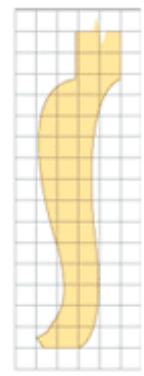

1 square = 1/2"

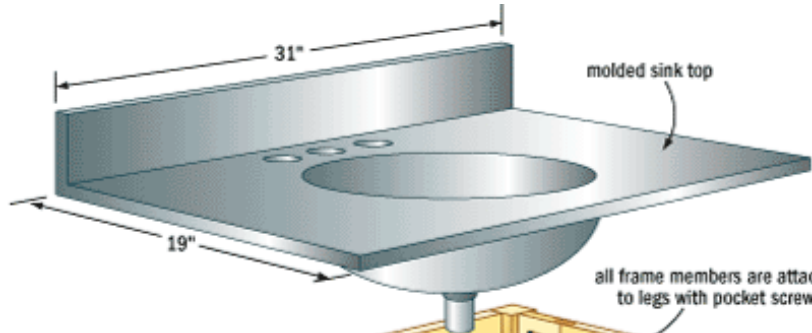

molded sink top

31"

19"

all frame members are attached to legs with pocket screws

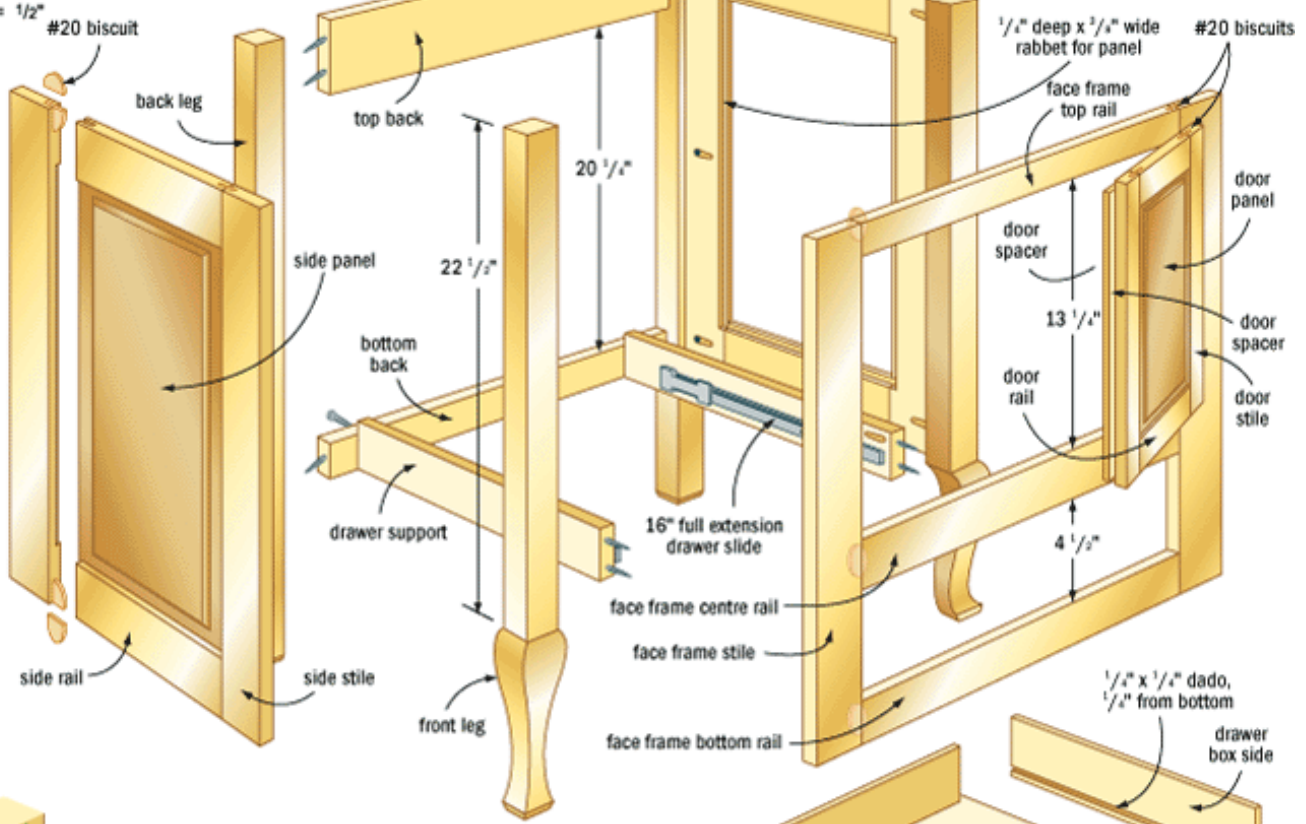

#20 biscuit

back leg

top back

20 1/2"

1/2" deep x 1/4" wide rabbet for panel

face frame top rail

#20 biscuits

side panel

22 1/2"

door spacer

door panel

door spacer

door stile

bottom back

13 1/4"

drawer support

16" full extension drawer slide

door rail

4 1/2"

side rail

side stile

front leg

face frame centre rail

face frame stile

face frame bottom rail

1/2" x 1/4" dado, 1/4" from bottom

drawer box side

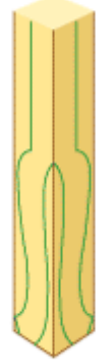

1. Trace outline onto glued-up leg member - trace onto two sides, lining up top back corners.

2. Cut along one face on bandsaw, keeping offcuts for use later on.

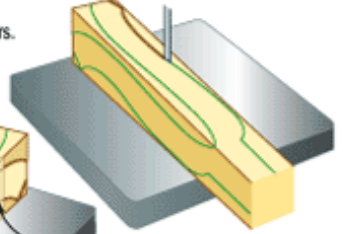

3. Put offcuts back together with masking tape to hold in place (masking tape allows you to see cutting lines).

4. Cut along second face, resulting in a cabriole leg.

5. Repeat process for other three legs, then sand to a smooth finish.

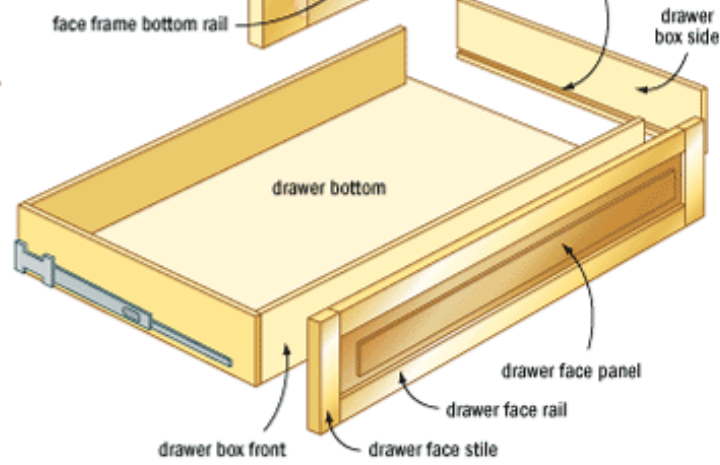

drawer bottom

drawer box front

drawer face panel

drawer face rail

drawer face stile