



## Rustic Armoire

*Most of my favorite project designs result from satisfying my own needs. The one shown on the next page is no exception. I designed and built this armoire to fit in a small room in our house that was designated by the builder to be a “study.” He must have pictured the future owners installing floor-to-ceiling bookshelves, a massive globe, and leather-covered easy chairs. What I needed, however, was a guest room—ahh, reality! The problem was that the room had no closet and not much space left over when the sleeper sofa was open for guests. This armoire neatly solved both my problems. Although it’s only 12” deep, it has a small hanging closet for clothes and enough drawer space to accommodate guests’ necessities. Because the armoire is so narrow, it must be attached to the wall to provide stability when the doors and/or drawers are open.*



### **Special Techniques**

- Mitering
- Dadoes
- Ripping

### **Materials and Supplies**

- 80 linear feet of  $\frac{3}{4}$ " x  $\frac{3}{4}$ " pine
- 44 linear feet of 1 x 3 pine
- 37 linear feet of 1 x 4 pine
- 13 linear feet of 1 x 6 pine
- 15 linear feet of 1 x 8 pine
- 33 linear feet of 1 x 12 pine
- 2 pieces of laminated pine or oak, each 20" x 72"
- 1 piece of  $\frac{1}{4}$ "-thick plywood, 20" x 34"
- 2 sheets of  $\frac{3}{4}$ "-thick plywood, each 4' x 8'
- 10 linear feet of 5" crown molding

## **Cutting List**

<b>Code</b>	<b>Description</b>	<b>Qty.</b>	<b>Material</b>	<b>Dimensions</b>
A	Wide Back	1	3/4" plywood	41-1/8" x 70-1/2"
B	Narrow Back	1	3/4" plywood	23-1/8" x 70-1/2"
C	Inner Vertical Support	8	3/4" x 3/4" pine	70-1/2" long
D	Shelf Support	3	3/4" x 3/4" pine	39-5/8" long
E	Side	2	1 x 12 pine	72" long
F	Inner Divider	1	1 x 12 pine	70-1/2" long
G	Top/Bottom	2	1 x 12 pine	65" long
H	Narrow Front Vertical	2	1 x 4 pine	72" long
I	Center Front Vertical	1	1 x 6 pine	72" long
J	Narrow Horizontal Frame	2	1 x 4 pine	36" long
K	Short Horizontal Frame	2	1 x 4 pine	18" long
L	Horizontal Inner Support	4	3/4" x 3/4" pine	39-5/8" long
M	Shelf	1	1 x 12 pine, ripped	41-1/8" long
N	Wide Horizontal Frame	2	1 x 6 pine	36" long
O	Short Inner Support	4	3/4" x 3/4" pine	21-5/8" long
P	Drawer Front/Back	4	1 x 8 pine	35" long
Q	Drawer Side	4	1 x 8 pine	9" long
R	Drawer Bottom	2	1/4" plywood	9-3/8" x 33-7/8"
S	Drawer Front	2	Laminated pine	8-1/2" x 35-1/2"
T	Top/Bottom Trim	4	1 x 3 pine	33" long
U	Side Trim	4	1 x 3 pine	11" long
V1	Upper Drawer Guide	4	1 x 4 pine	10-1/2" long
V2	Lower Drawer Guide	4	1 x 4 pine	9" long
W	Cabinet Door	2	Laminated pine	17-1/2" x 35-1/2"
X	Top/Bottom Door Trim	4	1 x 3 pine	15-1/4" long
Y	Side Door Trim	3	1 x 3 pine	37-1/2" long
Z	Wardrobe Door	1	Laminated pine	17-1/2" x 64"
AA	Top/Bottom Wardrobe Door Trim	2	1 x 3 pine	15" long
BB	Side Wardrobe Door Trim	2	1 x 3 pine	66-1/4" long

CC	Top Side Trim	2	1 x 4 pine	12" long
DD	Top Front Trim	1	1 x 4 pine	68" long

## **Hardware**

- 2 lbs. #6 x 1-4" flathead wood screws
- 1 lb. #6 x 2" flathead wood screws
- Approximately 50 2d finishing nails
- Approximately 200 3d finishing nails
- 6 offset door hinges
- 7 drawer pulls

## **Notes on Materials**

The armoire drawers and doors shown here are constructed from laminated pine boards. Most building-supply stores sell sections of wood that have already been laminated. You can laminate the boards yourself, of course, but I don't recommend doing this unless you're an experienced woodworker and own heavy-duty tools. Due to the number of boards and the overall size of the project, laminating is a bigger job than it may appear to be.

Although this armoire isn't wide enough to accommodate clothes hangers suspended parallel to its sides, you can certainly hang clothes parallel to its front and back. Just purchase a wooden trowel rod with removable arms, attach the arms to the inside top of the armoire, and cut the rod down to a length that will fit between the arms.

## **Constructing the Back**

1. The basic supporting frame for the armoire is nothing more than a large box. Although it requires quite a bit of space to construct, the actual assembly is very straightforward. Start by cutting one 41-1/8" x 70-1/2" wide back (A) and one 23-1/8" x 70-1/2" narrow back (B) from the 3/4" thick plywood.
2. Cut eight 70-1/2"-long inner vertical supports (C) from 3/4" x 3/4" pine.
3. Using *Figure 1* as a guide, glue two inner vertical supports (C) to the wide back (A), positioning the supports flush with the long edges of the wide back (A). Use 3d finishing nails, spaced about 6" apart, to secure the supports in place.
4. Cut three 39-5/8"-long shelf supports (D) from 3/4" x 3/4" pine.
5. Glue one shelf support (D) to the wide back (A), between the two vertical supports (C) and 39-3/4" down from what will be the top of the finished armoire, as shown in *Figure 1*. Secure the shelf support with 3d finishing nails spaced about 6". It doesn't make any difference which end of the wide back (A) you choose as the top, but now is the time to decide.

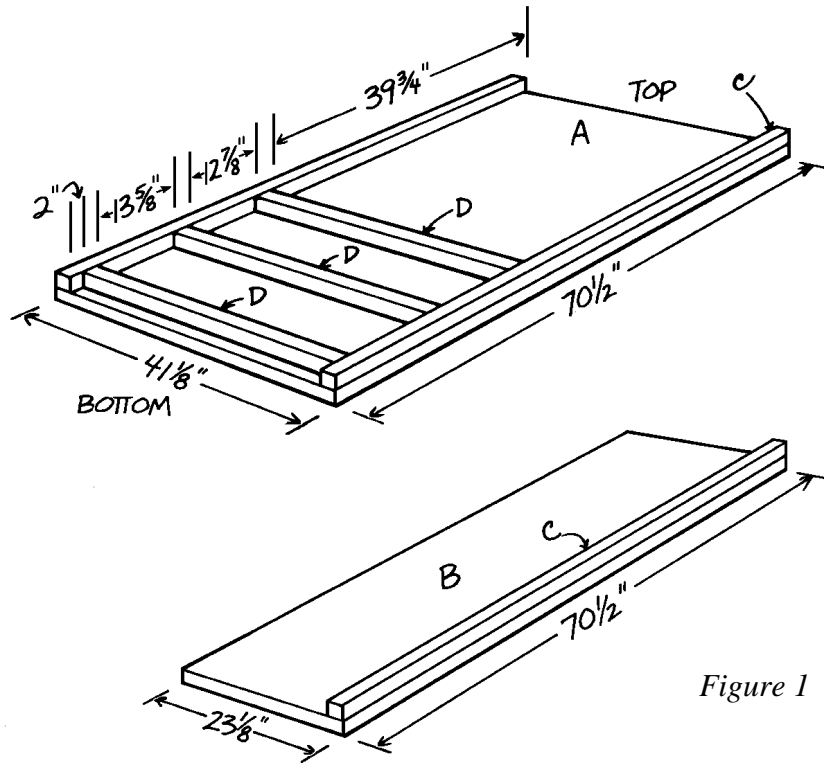

Figure 1

6. Glue a second shelf support (D) to the wide back (A), 12-7/8" down from the first support, in the same manner that you attached the first one, as shown in *Figure 1*.
7. Nail and glue the remaining shelf support (D) 2" from the bottom edge of the wide back (A).
8. Glue and nail one inner vertical support (C) to the narrow back (B), flush with one long edge, as shown in *Figure 1*. Secure the support with 3d finishing nails spaced about 6" apart.

### **Adding the Sides and Inner Divider**

1. Cut two 72"-long sides (E) from 1 x 12 pine
2. Glue one inner vertical support (C) flush with one 70-1/2"-long edge of one side (E), as shown in *Figure 2*. Center the inner vertical support (C), leaving a 3/4" gap at each end of the side (E). Secure the support with 3d finishing nails spaced about 6" apart.
3. Repeat Step 2 to attach another inner vertical support (C) to the remaining side (E).
4. Cut one 70-1/2" long inner divider (F) from 1 x 12 pine.

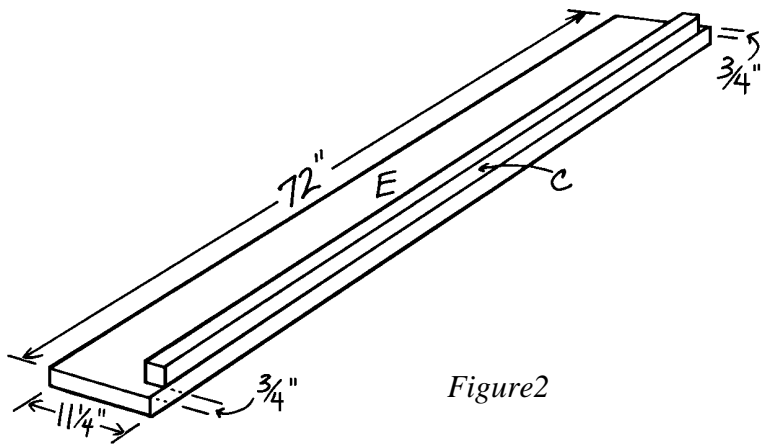

Figure 2

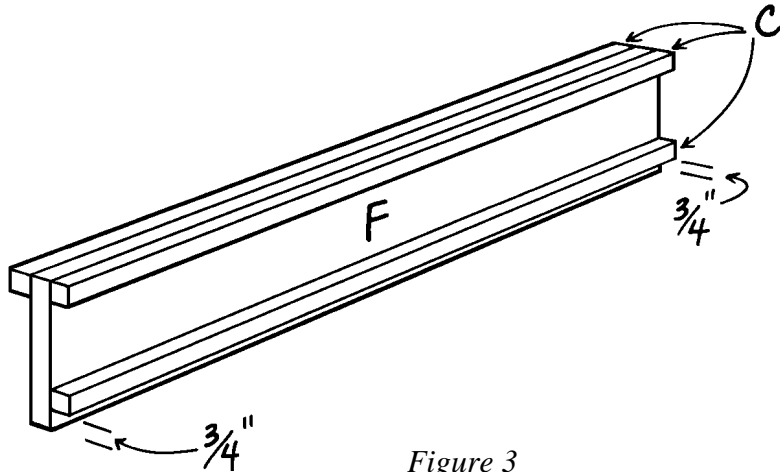

Figure 3

5. Glue an inner vertical support (C) to each side of the inner divider (F), flush with one edge as shown in *Figure 3*. Secure with 3d finishing nails spaced about 6" apart.
6. Glue a third inner vertical support (C) to the inner divider (F), offsetting it  $\frac{3}{4}$ " from the other long edge, as shown in *Figure 3*. Secure the support with 3d finishing nails spaced about 6" apart.
7. Place the inner divider (F) along the edge of the wide back assembly, facing its offset inner vertical support (C) away from the wide back (A), as shown in *Figure 4*. Glue the inner divider (F) and wide back assembly together. Then insert 2" screws at an angle through the bottom  $\frac{3}{4}$ " wide offset on the inner divider (F) and into the inner vertical support (C) that is attached to the wide back (A). Space the screws about 4" apart.
8. Fit the narrow back (B) underneath the offset inner vertical support (C) on the inner divider (F), as shown in *Figure 4*. Glue the narrow back in place and insert 1-1/4" screws, spaced about 4" apart through the inner vertical support (C) on the inner divider (F) and into the narrow back (B).
9. Center one side (E) on the wide back (A), leaving a  $\frac{3}{4}$ " gap at each end, as shown in *Figure 4*. Glue the side (E) in place and insert screws, spaced about 4" apart, through the side (E) to attach it alternately to both the inner vertical support (C) and to the edge of the wide back (A). Use 2" screws to attach it to the wide back (A) and 1-1/4" screws to attach it to the inner vertical support (C).

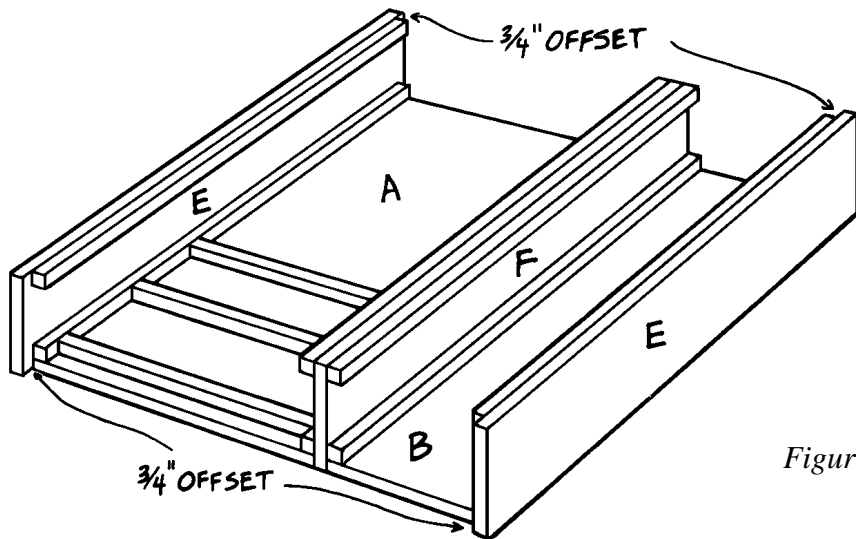

Figure 4

- Center the remaining side (E) along the edge of the narrow back (B), leaving a  $\frac{3}{4}$ " gap at each end, as shown in Figure 4. Glue the side in place and secure with screws, just as you secured the side (E) in Step 9.

### **Adding the Top and Bottom**

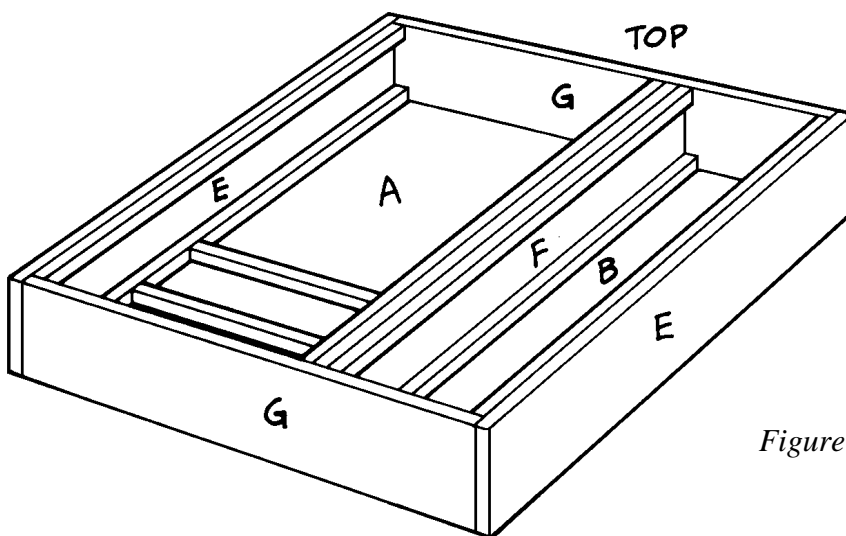
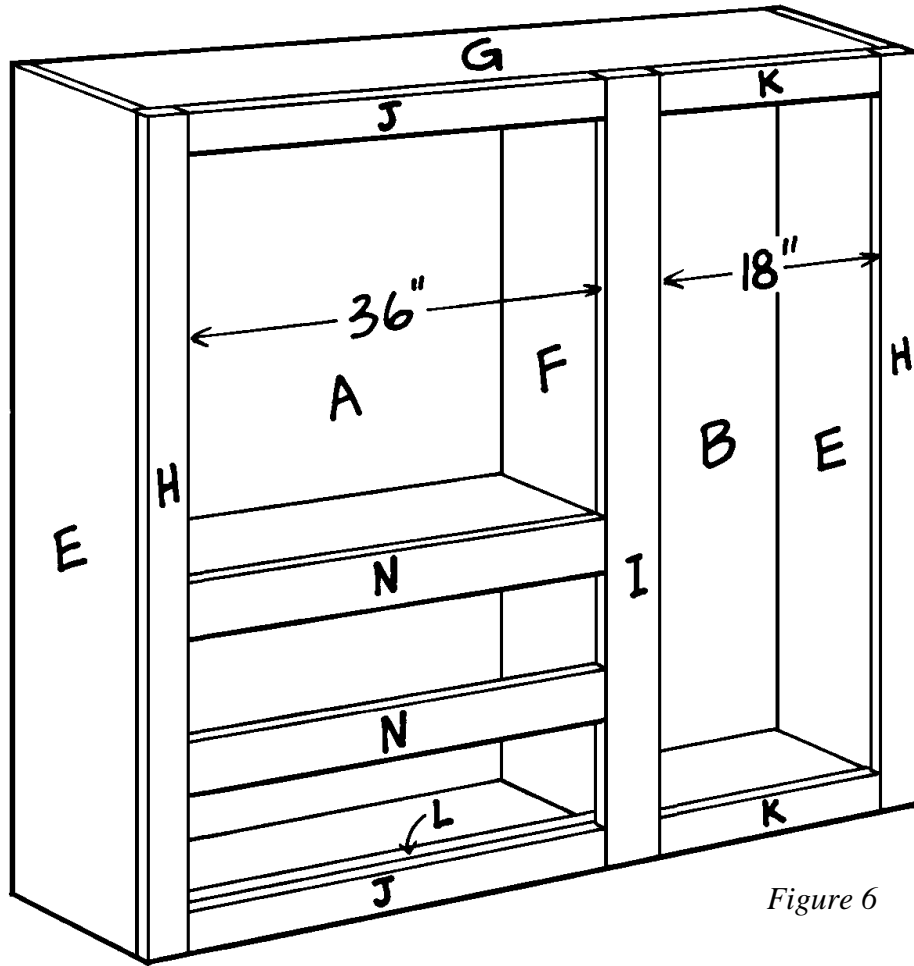

Figure 5

- Cut two top/bottom pieces (G) from 1 x 12 pine, each measuring 65" long.
- Fit one top/bottom piece (G) between the two sides (E), as shown in Figure 5. Note that the top/bottom piece (G) fits over the ends of the wide and narrow backs (A and B) and the inner divider (F). Glue the top (G) in place and insert 2" screws, spaced about 3" apart, through the sides (E) and into the ends of the top/bottom piece (G). Also attach the top/bottom piece (G) to the inner divider (F) and to the wide and narrow backs (A and B) by inserting 2" screws, spaced about 3" apart, through the top piece (G) and into the ends of pieces A, B, and F.

3. Repeat Step 2 to attach the other top/bottom piece (G) at the other end of the assembly, as shown in *Figure 5*.



*Figure 6*

### ***Adding the Front Frame pieces***

1. The front frame pieces are not difficult to add, but do take the time to make certain that all of the pieces are absolutely square. One piece of the frame that is off will affect the way the shelves and drawers fit, so before you attach each piece, double-check your work. Start by cutting two 72"-long narrow front verticals (H) from 1 x 4 pine.
2. Glue the narrow front verticals (H) to the frame assembly, fitting them over the edges of the sides (E) and the top/bottom pieces (G), as shown in *Figure 6*. Insert 2" screws, spaced about 4" apart, through each narrow front vertical (H) and into the edges of the sides (E) and top/bottom pieces (G).
3. Cut one 72"-long center front vertical (I) from 1 x 6 pine.

- Center the center front vertical (I) over the edge of the inner divider (F). It should extend  $2\frac{3}{8}$ " on either side of the inner divider (F). At this point, check the spacing on the front of your armoire. (Well, it's almost an armoire by now!) The distance between the center front vertical (I) and the narrow front vertical (H) on the side of the armoire that contains the wide back (A) should be exactly 36". The distance between the center front vertical (I) and the narrow front vertical (H) on the other side of the armoire should be exactly 18". Measure across each of the openings at the top, bottom, and at least two mid-points. If your measurements are off, alter the remaining front frame pieces, drawers, and doors so that they'll fit properly.
- Cut two 36"-long narrow horizontal frames (J) from 1 x 4 pine.

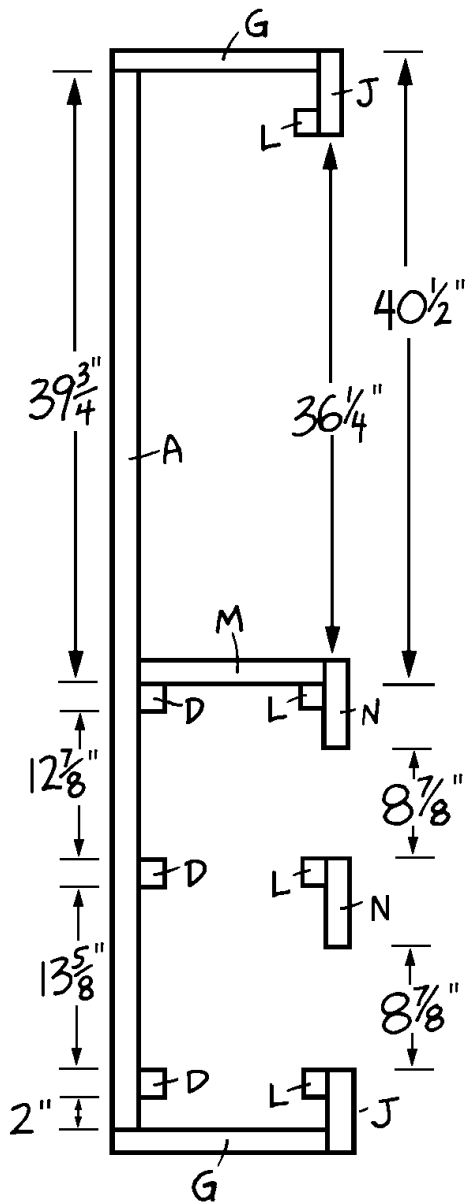

Figure 7

- Glue one narrow horizontal frame (J) at the top of the 36"-wide opening on the left side of the armoire, between the center front vertical (I) and the narrow front vertical (H), as shown in *Figure 6*. Insert 2" screws, spaced about 4" apart, through the narrow horizontal frame (J) and into the edge of the top (G).
- Repeat Step 7 to attach the remaining narrow horizontal frame (J) at the bottom of the 36"-wide opening, as shown in *Figure 6*.
- Cut two 18"-long short horizontal frames (K) from 1 x 4 pine.
- Glue one short horizontal frame (K) at the top of the 18"-wide opening on the right side of the armoire, between the center front vertical (I) and the narrow front vertical (H), as shown in *Figure 6*. Insert 2" screws through the short horizontal frames (K); and into the edge of the top (G).
- Repeat Step 10 to attach the remaining short horizontal frame (K) at the bottom of the 18"-wide opening on the right side of the armoire, as shown in *Figure 6*.

### **Adding the Inner Supports and Shelves**

- Cut four  $39\frac{5}{8}$ " horizontal inner supports (L) from  $\frac{3}{4}$ " x  $\frac{3}{4}$ " pine. These will fit behind the narrow and wide horizontal frames (J and N)

and will support the inner shelves as well as stabilizing the narrow horizontal frames (J) that just attached. A cutaway view of the placement of the inner supports on the left side of the armoire is provided in *Figure 7*.

2. Glue one horizontal inner support (L) onto the inner edge of each of the narrow horizontal frame pieces (J), positioning them as shown in *Figure 7*. Secure the supports with 3d finishing nails, spaced 6" apart.
3. Attach a third horizontal inner support (L) 40-1/2" from the top edge of the armoire, across the front opening. It should be exactly level with the shelf support (D), which you previously attached to the wide back (A). Use 3d finishing nails to secure it to the back faces of the narrow front vertical (H) and the center front vertical (I).
4. Cut one 41-1/8" upper shelf (M) from 1 x 12 pine, and rip the shelf to 10-1/2" in width. The shelf will fit on top of the horizontal inner support (L) which you just attached and the shelf support (D) on the wide back (A), as shown in *Figure 7*. In order to make the shelf fit, each of the corners must be cut out to accommodate the inner vertical supports (C) inside the armoire. Cut out a square from each corner of the upper shelf (M), measuring just over 3/4" x 3/4", as shown in *Figure 8*.



*Figure 8*

5. Fit the upper shelf (M) over the horizontal inner support (L) and the shelf support (D). Glue the shelf in place, and secure with 3d finishing nails spaced about 6" apart.
6. Cut two 36"-long wide horizontal frames (N) from 1 x 6 pine.
7. Glue one wide horizontal frame (N) over the raw edge of the upper shelf (M), between the center front vertical (I) and the narrow front vertical (H), as shown in *Figures 6 and 7*. Insert 1-1/4" screws, spaced about 6" apart, through the face of the wide horizontal (N) and into the edge of the upper shelf (M).
8. We're finally going to use that fourth horizontal inner support (L) that you've been so worried about! Bet you thought we forgot. Attach this support (L) across the 36"-wide opening, 12-7/8" below the horizontal inner support (L) that is under the upper shelf (M), as shown in *Figure 7*. Nail and glue the support (L) to the inner faces of the center front vertical (I) and the narrow front vertical (H).

9. Glue the remaining wide horizontal frame (N) to the horizontal inner support (L), which you just attached. The long upper edge of the wide horizontal frame (N) should be flush with the top edge of the horizontal inner support (L).
10. Cut four 21-5/8"-long short inner supports (O) from 3/4" x 3/4" pine. These will fit behind each of the short horizontal frames (K) on the right side of the armoire to stabilize the joints.
11. Glue and nail one short inner support (O) to the inner face of the short horizontal frame piece (K) at the top of the armoire, flush with its edge. Secure the support with 3d finishing nails spaced about 6" apart.
12. Repeat Step 11 to attach the second short inner support (O) to the short horizontal frame piece (K) at the bottom of the armoire.

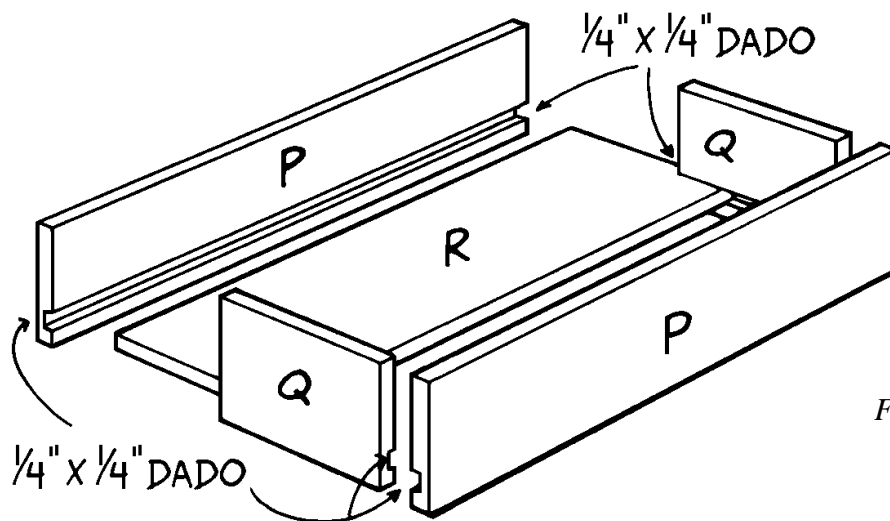

Figure 9

### **Making the Drawers**

1. There are two identical drawers in this armoire. Both are constructed as shown in *Figure 9*. Start by cutting the following parts from 1 x 8 pine: two 35"-long drawer front/back pieces (P) and two 9"-long drawer sides (Q).
2. To accommodate the plywood drawer bottoms, cut a 1/4" x 1/4" dado on the inside of each drawer piece (P and Q), 3/8" from its lower edge.
3. Cut two 9-3/8" x 33-7/8" drawer bottoms (R) from 1/4"-thick plywood. Assemble each drawer as shown in *Figure 9*. Note that the drawer front/back pieces (P) overlap the ends of the drawer sides (Q). Use glue and 3d finishing nails at each end of the overlapping boards. Leave the drawer bottoms (R) floating freely within their dados. The drawer fronts (S) will be added later.

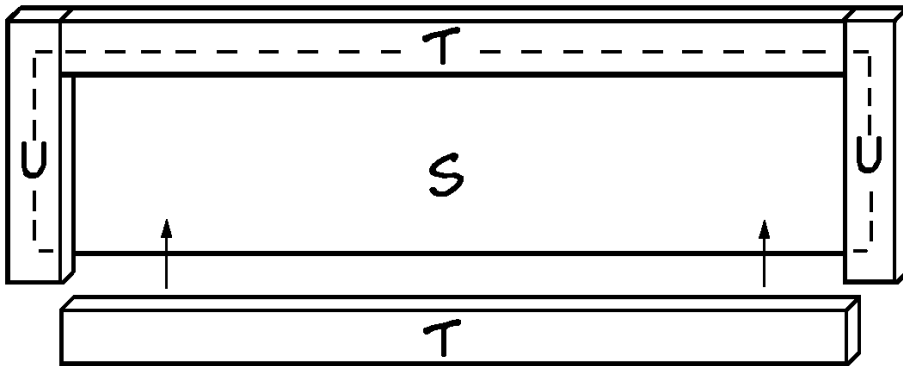

Figure 10

### **Making the Drawer Fronts**

1. The drawer fronts are nothing more than rectangles of laminated pine trimmed with a border of 1 x 3 pine. You'll need to make sure that each finished assembly is perfectly square. Start by cutting one 8-1/2" x 35-1/2" drawer front (S) from laminated pine.
2. Cut two 33"-long top/bottom trim pieces (T) from 1 x 3 pine.
3. Cut two 11'-long side trim pieces (U) from 1 x 3 pine.
4. Using *Figure 10* as a guide, place the four trim pieces (T and U) on a level surface. Center the drawer front (S) over the trim pieces, leaving a 1-1/4" border of trim visible on each of the four sides of the drawer front (S). Glue and nail the pieces together, using 3d finishing nails spaced about 4" apart.
5. Repeat Steps 1 through 4 to assemble the second drawer front. Set the drawer fronts aside.

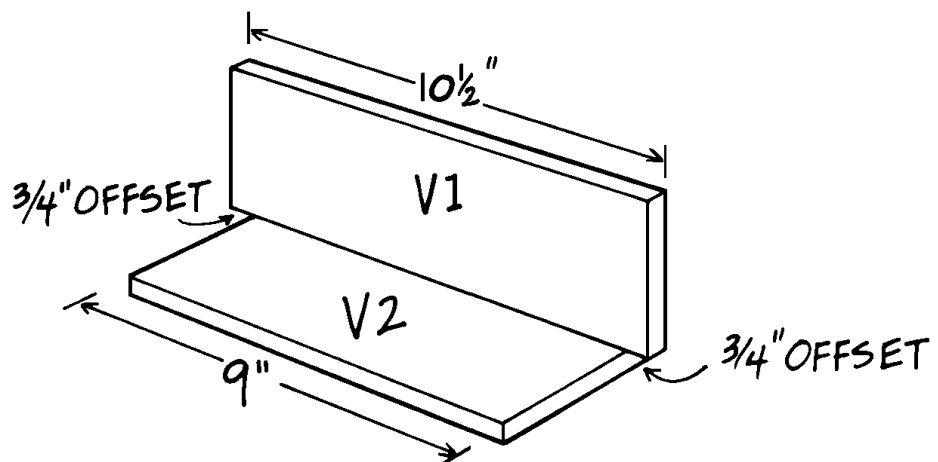
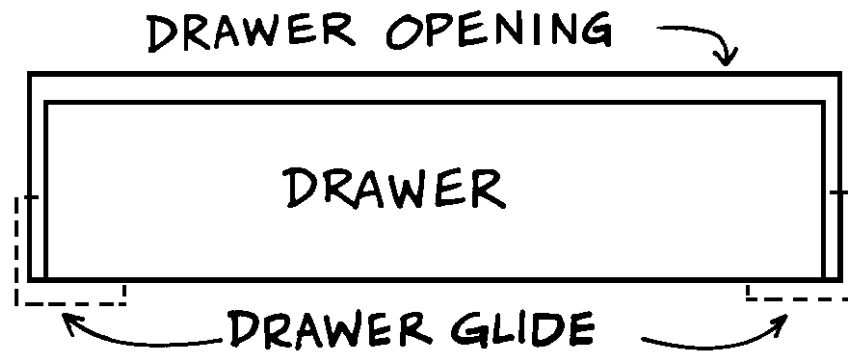

Figure 11

## **Adding the Drawer Guides**

1. Cut four 10-1/2"-long upper drawer guides (V1) from 1 x 4 pine. Also cut four 9"-long lower drawer guides (V2) from 1 x 4 pine.
2. Glue one upper guide (V1) and one lower guide (V2) together, as shown in *Figure 11*, leaving a 3/4" space at each end of the upper guide. Note that the back face of the upper guide should be flush with the back edge of the lower guide. Secure the pieces with three 1-1/4"-long screws spaced evenly along the joint.
3. Repeat Step 2 three more times, using the remaining six drawer guide pieces (V1 and V2), to make a total of four assembled drawer guides.
4. Fit the first two L-shaped drawer guides between the horizontal inner support (L) and the shelf support (D) on the sides of the drawer opening, with their open sides facing each other and positioned so that the drawer is centered, as shown in *Figure 12*. Check to make certain that the drawer fits snugly between them. Remove the drawer; then glue and nail the guides in place.
5. Repeat Step 4 to attach the remaining two drawer guides in the second opening.



*Figure 12*

## **Making the Cabinet Doors**

1. The cabinet doors are constructed in the same manner as the drawer fronts, with the exception that the right-hand cabinet drawer has no trim on the edge that sits next to the left-hand door. Start by cutting two 17-1/2" x 35-1/2" cabinet doors (W) from laminated pine.
2. Cut four 15-1/4"-long top/bottom door trim pieces (X) from 1 x 3 pine.
3. Cut three 37-1/2"-long side door trim pieces (Y) from 1 x 3 pine.
4. Using *Figure 13* as a guide, arrange the five trim pieces (X and Y) on a level surface. (Note the 1/4" gap between the Y piece in the center and X pieces to the right of it.) Center

the two door fronts (W) over the trim pieces, leaving a  $\frac{1}{2}$ " gap between the two. There should be a  $1\text{-}\frac{3}{8}$ " border of trim visible along each side of the doors (W) and a 1" border at the top and bottom. Glue and nail the door (W) on the left to the trim (X and Y) that it covers, using 3d finishing nails spaced about 4" apart. Glue and nail the door on the right to the two top/bottom trim pieces (X) and to the side door trim piece (Y) on the right, but do not attach this door to the piece of Y trim in the center.

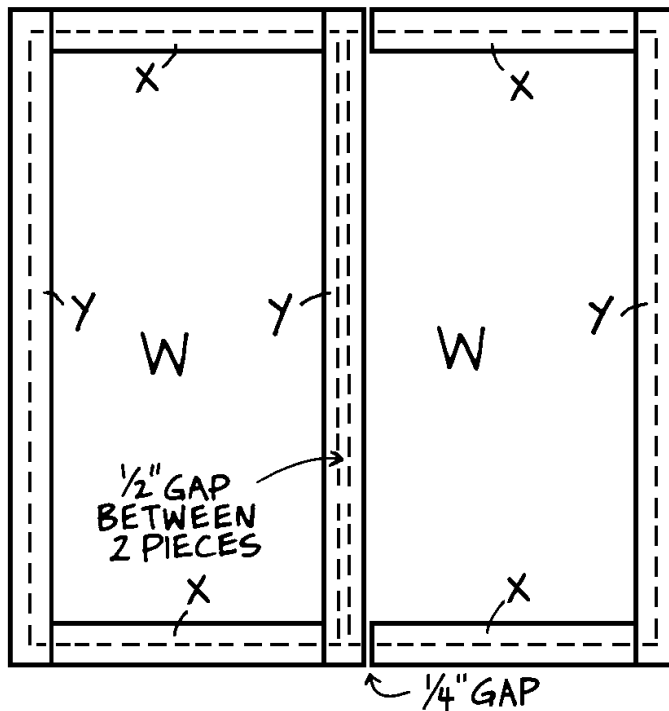

Figure 13

### **Making the Wardrobe Door**

1. The wardrobe door is made in the same manner as the drawer fronts and the cabinet doors; only the measurements are different. Start by cutting one  $17\text{-}\frac{1}{2}$ " x 64" wardrobe door (Z) from laminated pine.
2. Cut two 15"-long top/bottom wardrobe door trim pieces (AA) from 1 x 3 pine
3. Cut two  $66\text{-}\frac{1}{4}$ "-long side wardrobe door trim pieces (BB) from 1 x 3 pine.
4. Using *Figure 14* as a guide, arrange the four trim pieces (AA and BB) on a level surface. Center the door front (Z) over the trim pieces, leaving a  $1\text{-}\frac{1}{4}$ " border of trim visible on each side of the wardrobe door front and a  $1\text{-}\frac{1}{8}$ " border of trim visible at the top and bottom of the door front. Glue the pieces together and secure with 3d finishing nails spaced 4" apart.

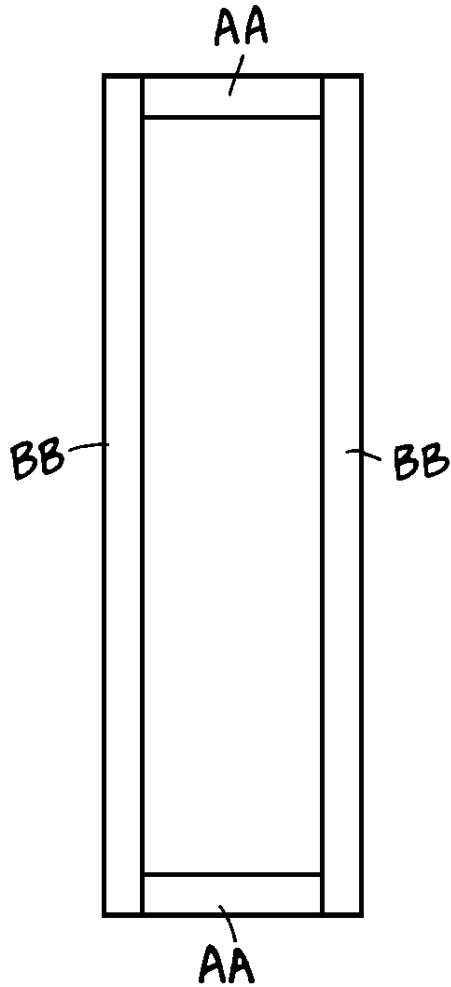

Figure 14

## ***Installing the Doors***

1. Slide the assembled drawers into their openings, placing a scrap piece of wood between the back of each one and the back of the armoire to hold the drawers flush with the front of the armoire. Use heavy-duty, double-sided tape to stick a drawer front temporarily in place on each drawer until you have both drawer fronts positioned exactly right. Then attach the fronts to the drawers by inserting three 1-1/4" screws through each drawer and into each drawer front.
2. First measuring carefully, install the hinges on the doors so that the hinges are positioned the same distance from the top and bottom of the door.
3. Have someone help you position the doors and attached hinges over the door openings. Line up each door so that it's even with the door and/or drawers next to it and make sure that none of the doors binds or scrapes against surrounding surfaces. When the doors are aligned, attach the hinges to the armoire.
4. Attach the drawer pulls to each of the drawers and cabinet doors, spacing them evenly and aligning them with one another.

## ***Adding the Top Trim***

1. The last step (whew!) is to add the top trim to the armoire. As you can see in the photo, we added two layers: a first layer of 1 x 4 pine and a second layer of crown molding. Be sure to take careful measurements for your trim pieces, as they should be cut to fit exactly. Start by measuring and cutting two 12'-long top side trim pieces (CC) from 1 x 4 pine and one 68"-long top front trim piece (DD) from 1 x 4 pine.
2. Glue the three trim pieces (CC and DD) to the top of the armoire so that each piece overlaps the armoire by 1" and extends above it by 2-1/2". Secure the trim with 3d finishing nails spaced about 6" apart.
3. Measure and cut three pieces of crown molding to fit above the 1 x 4 pine trim, mitering the corners to fit perfectly. Glue the crown molding onto the 1 x 4 pine trim, overlapping the trim by only 1". Secure the molding to the trim with 2d finishing nails spaced about 4" apart.

## ***Finishing***

1. Countersink all nails. Fill any nail or screw holes with wood filler.
2. Sand all surfaces thoroughly.
3. Paint or stain the completed armoire the color of your choice. We used a light green wood stain.
4. Take an admiring look at your handiwork. Then figure how to get it moved to the room where you will use it! Don't forget that it should be attached to the wall for stability.



**Enjoy other indoor  
and outdoor projects  
from**