

133
**JOINTED HARDWOOD
BOOKCASE**



The softly flowing lines and sturdy jointed construction of this hardwood bookcase can be achieved only by careful workmanship, fitting and shaping each part to blend with the whole. It is a job for an experienced craftsman.

The care begins with the selection of wood. The sides are of richly textured cherry, noted for its graceful figuring, and the horizontal members are of light-colored ash, straight grained and durable. These hardwoods are seldom found at reasonable prices in the widths needed for the project; therefore, it is necessary to edge-join narrower boards (see opposite page). Choose the boards carefully so that the colors and figures will blend; to bring up the figure of unplanned wood so that you can see it, brush a little paint thinner on the surface. In any case, the faces of the boards must be planed flat before edge-joining and planed again afterward for a good, flush surface. Buy rough lumber at least 1/4 inch thicker than specified in the chart below; buy dressed lumber at least 1/8 inch thicker.

The joinery looks deceptively simple. The shelves are glued into dados in the sides with no attempt to conceal the joints. This means that the dados must be precisely cut to the thickness of the shelves—there is no tolerance for error. In this project instructions are given for fitting these and the several tongue-and-groove joints when using a dado head on a radial arm or table saw.

All edges and corners are rounded and

shaped by hand. This is a matter of esthetic judgment, based in part on the figure and quality of the wood you are using. A spokeshave and drawknife are the tools of choice, but you can use a rasp, plane, Surform tool, and sandpaper to good effect. Note that the edge of the plinth front (H) is 3/16 inch below the upper face of the bottom piece (E) and that both corners are rounded where they meet. This is a traditional way of turning a possible defect into a design advantage. The shelf unit is not joined to the plinth; if the two surfaces were flush, the crack between them would always show. In this way, the crack is concealed at the bottom of a graceful ripple.

Because the weight of a full bookcase will tend to force the joints of the plinth apart, the mitered joints are reinforced with splines, and laminated corner blocks are glued all around.

Finishing: To bring out the warmth of the wood, rub in several coats of tung oil, allowing plenty of drying time.

Parts list

Part	Name	Quantity	Thickness	Width	Length	Material
A	Side	2	3/4"	12" ☆	44 1/2"	Cherry
B	Top shelf	1	3/4"	7 3/4"	24 7/8"	Ash
C	Middle shelf	1	3/4"	9 3/8"	24 7/8"	Ash
D	Bottom shelf	1	3/4"	11 3/4"	24 7/8"	Ash
E	Bottom	1	1 3/8"	11 3/4"	25 1/8"	Ash
F	Top	1	1 1/4"	10"	27 1/4"	Ash
G	Back	1	3/4"	25 1/8" ☆	44 3/8" ☆	A-2 cherry plywood
H	Plinth front	1	1 1/4"	4"	29"	Ash
I	Plinth side	2	1 1/4"	4"	14" ☆	Ash
J	Plinth back	1	1 1/4"	3"	26 3/8"	Ash
K	Plinth spacer	1	1 1/4"	3" ☆	10 3/8" ☆	Ash
L	Spline	6	5/16"	1 1/2"	2"	Ash
M	Corner block laminate	28	3/4"	1 1/4"	1 1/4"	Ash

☆ Measurement is approximate; cut to fit during construction.

Tools and materials: Drill with twist bits and countersink. Table saw or radial arm saw with combination blade, dado head, and splining jig. Band, saber, or coping saw. Several 6" C-clamps and 6' bar or pipe clamps, quick-action clamps (optional). Smooth plane, jack plane, block plane. Rasp, spokeshave, drawknife, and/or Surform tool. Wooden mallet, 1/4" and 3/8" straight chisels. Try square, combination square, framing square, steel ruler, steel tape rule, wooden extension rule, knife, pencil. Nos. 60, 80, 120, and 220 sandpaper. Paraffin or beeswax, carpenter's glue. Wood (see above). One 2 1/4" No 10

flathead wood screw, 3/4" No 6 panhead wood screws.

Edge-joining boards

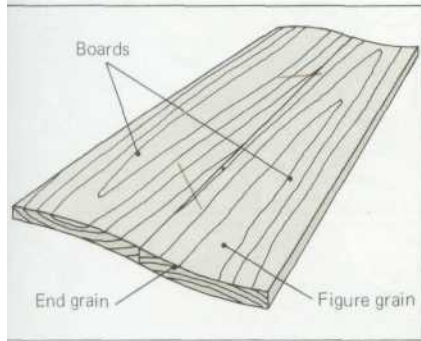

Choosing boards. First, look at the end grain. As a board ages, it will tend to cup in the opposite direction from the arch of the annual rings. To minimize the effect of this warpage, lay boards side by side so that the direction of the arch alternates. Align boards so that their figures blend into an attractive pattern. Use a pencil to make a few slanting lines across each joint to guide in realignment. Saw boards to approximate length.

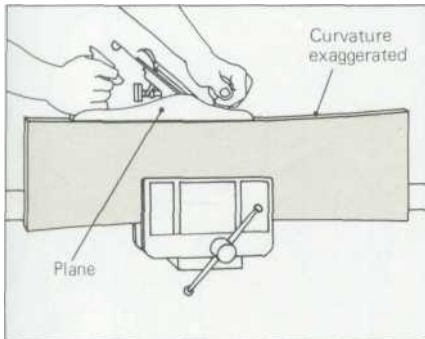

Preparing boards. Plane to within 1/8 in. of final thickness. Plane edges smooth and square. The boards will eventually shrink a little more across the ends than across the middle; to prevent the wood from splitting at the ends when this happens, plane both edges of joint slightly concave—the center of the joint should be separated by a gap that you can squeeze shut with your hands (less than 1/64 in.).

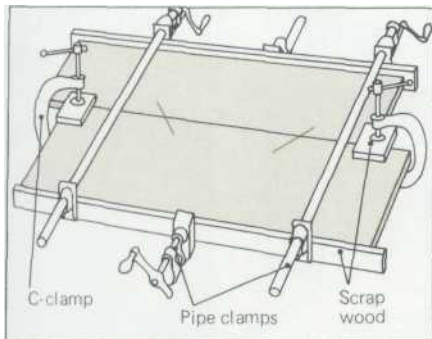

Gluing and clamping. Apply all clamps before gluing, mark positions and order of application. Then unclamp and apply a thin even coat of glue to both edges of joint. Reclamp quickly, tightening firmly but not forcing out all glue. First, use C-clamps to align faces of boards at both ends. Then apply bar or pipe clamp across center, forcing faces of boards into alignment, if necessary, as you tighten. Remaining clamps should alternate top and bottom.

Exploded view shows how parts fit together. All joints are glued except those securing the back (G) to the shelf unit which are secured with 3/4-in. No. 6 panhead wood screws (Step 18); use a 5/64-in. bit for pilot holes. The shelf unit is not joined to the plinth but rests on the plinth back (J) and spacer (K) and inside the rabbets of the plinth front (H) and sides (I)—if a plinth side were glued to a side (A) of the shelf unit, the fact that the grains run in opposite directions would cause stress, and probably splitting, in the shelf side. The corner blocks (M) that reinforce the joints of the plinth are intentionally laminated with the wood grains running in alternate directions, ensuring that no joint is compromised by the sole presence of end grain. The front joints of the plinth are further reinforced by splines (L). Use 1/2-in. thick, order ash stock planed to thickness, or cut a strip to thickness on a table saw, then dado slots to fit (Step 15). There is little danger of the shelf unit slipping backward on the plinth, but if you wish to ensure its security, drill and countersink a 3/16-in. hole up through the front part of the plinth spacer (K) and drive a 2 1/4-in. No. 10 wood screw through it; drill a 1/64-in. pilot hole in the bottom. You can also glue two slotted blocks onto the plinth back (J) to receive additional, smaller screws.

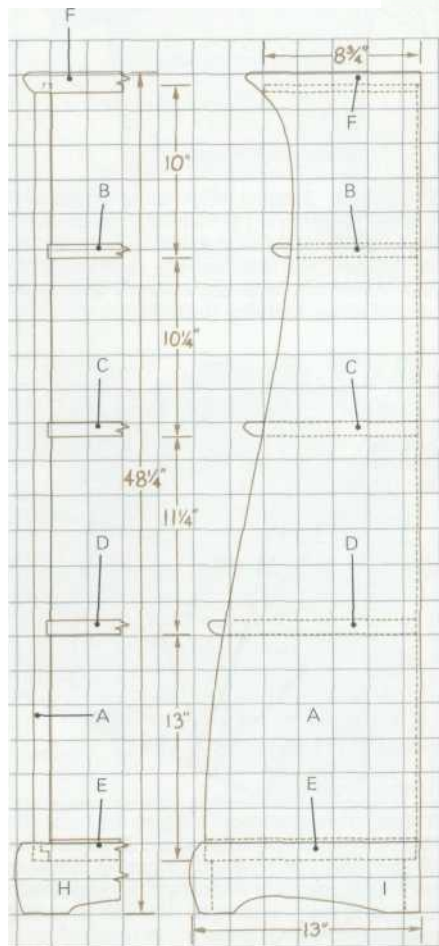
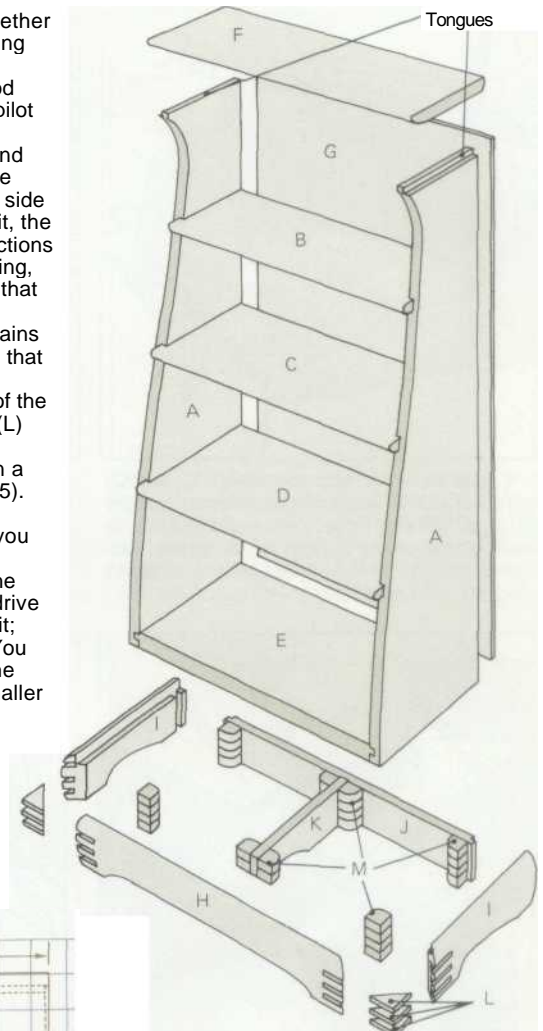

After joining boards for sides (A), shelves (B, C, and D), bottom (E), and top (F), cut all stock to final length, and plane to final thickness. Rip shelves, top, and bottom to width. Use 2-in. grid (see p.48) to make full-size patterns for sides (A), plinth front (H), and plinth sides (I) and to guide in shaping the protruding edges of the top and shelves (Step 4). To make the pattern for the plinth front, duplicate the section shown and its mirror image, connect the lines for the cutout portion with an arc that rises to the same height as the cutouts in the sides.

Trace patterns onto side pieces (A). Before cutting the long S curve, use a table saw or radial arm saw to make a square cut from the top edge of each piece, 8 3/4 in. from the back, for the front of the tongues. Then rough-cut the pieces individually with a band saw, saber saw, or coping saw. Clamp them back to back, and shape them simultaneously to the line with a rasp, drawknife, or spokeshave. Cut rabbets into the top outer edges of the sides, leaving tongues 1/2 in. thick and 1/2 in. deep. Cut the dados for the shelves 1/4 in. deep, marking the width of each dado from the thickness of the shelf that will fit into it. (Measurements between shelf dados are given from bottom edge to bottom edge; to achieve dado cuts that match the thickness of the wood, make test cuts in scrap wood inserting paper washers between dado heads as necessary.) To ensure that the shelves will be level, lay the side pieces side by side and mark across both at once.

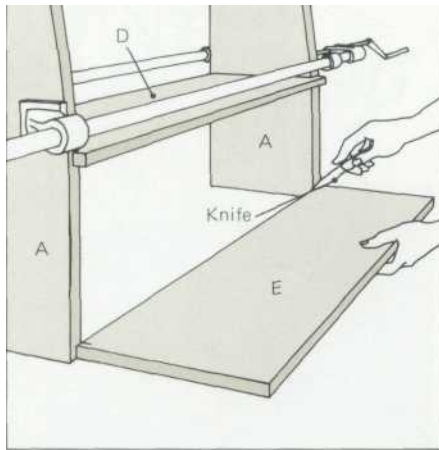

1. Clamp sides (A) and shelves (B, C, and D) together with all joints square. Center bottom (E) against front edge; use a sharp knife to mark points where bottom meets sides. Rabbit both ends of E to these marks, leaving tongues centered and 1/2 in thick.

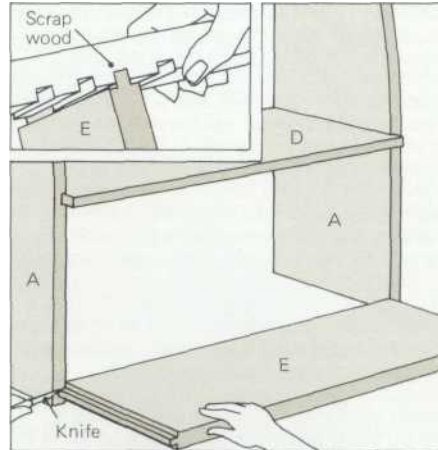

2. With a sharp knife mark position and thickness of tongues on front and back of sides (A). Make test cuts in scrap wood to set dado heads to exact width and depth needed; then cut dados in sides to receive tongues of bottom. Reassemble unit with bottom in place.

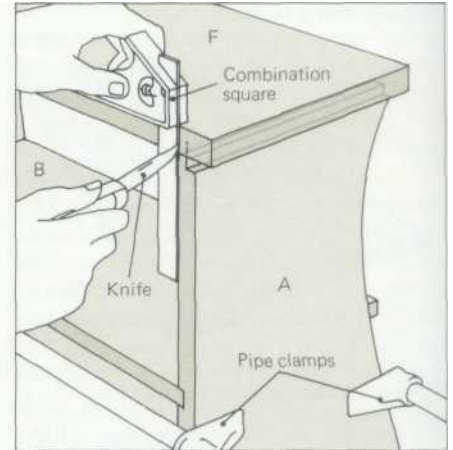

3. Position top (F) so its back is flush and overhang is equal on sides. Mark width of tongues on back of top and mark front of tongues on underside. Cut dados to receive tongues (see Step 2). Dados do not go all the way through; finish blind ends with a chisel.

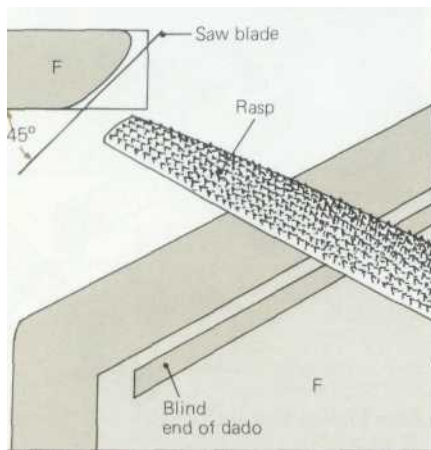

4. With top in place, sketch rounded patterns on edges of top (F) and shelves (B, C, and D). Disassemble unit and shape edges; use table saw set at 45° to remove the main body of wood from lower edge. Finish shaping with jack plane, rasp, and No 60 sandpaper.

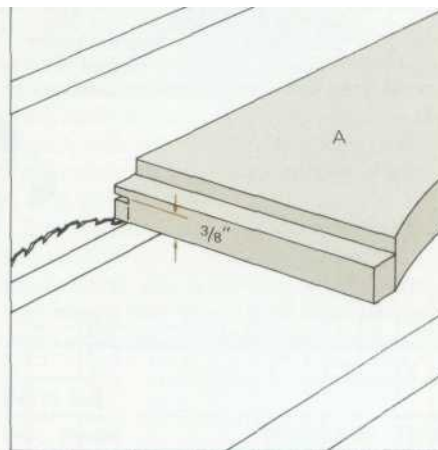

5. Cut 1/4-in rabbets 3/8 in deep in back of sides (A) and top (F) to receive 1/4-in. plywood back. Sand all interior surfaces with No 80 sandpaper, then with No 120, and finally No 220. Assemble shelves, bottom, and sides without glue, applying all clamps.

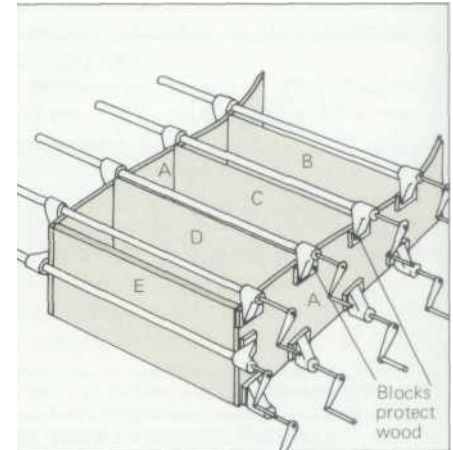

6. Use a bar or pipe clamp across the front and back of each shelf and the bottom, and apply another across center of bottom to prevent buckling. Mark placement of clamps and disassemble. Apply glue to dados and re-clamp quickly. Let glue dry.

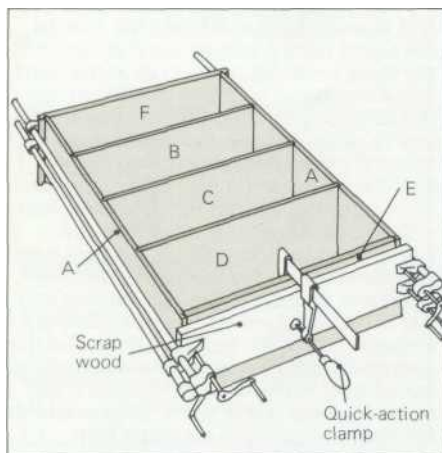

7. Before gluing top (F) to its tongues, cut a piece of scrap the same length as top to overhang the bottom and equalize the pressure of clamping. Apply glue to dados and clamp top in place, using two bar or pipe clamps on each end, running to scrap on bottom.

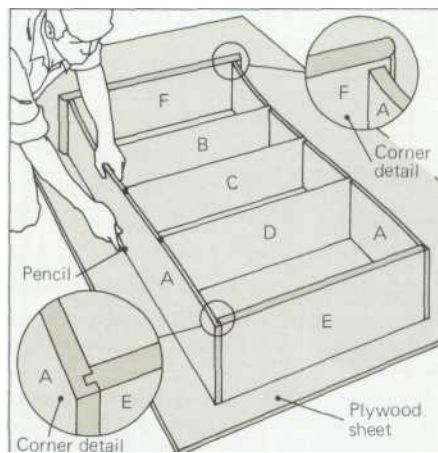

8. To find most attractive figure for back (G) lay shelf unit on plywood sheet. Trace outline of unit, and cut plywood to outline. Then fit back precisely within rabbets on sides and top. Sand back with Nos 80, 120, and 220 sandpaper; do not secure it to unit.

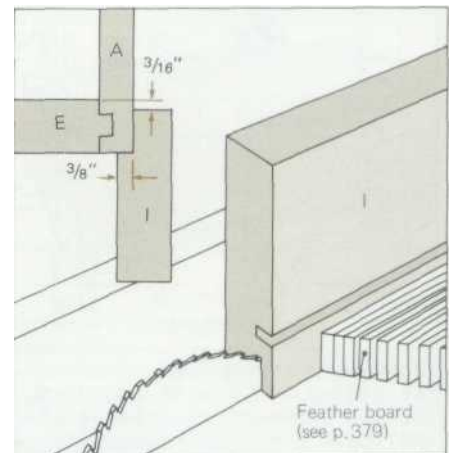

9. Rip stock for plinth front (H) and sides (I), and plane to width. Cut each piece 3-4 in. longer than specified. Cut rabbets 3/8 in. deep along one face of each piece to receive shelf unit; to find width of rabbets, deduct 3/16 in. from thickness of bottom (E). **606**

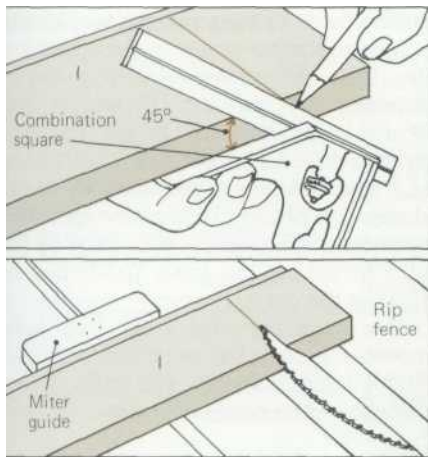

10. Cut 45° bevels on front end of each plinth side (I) and one end of front (H) For accurate cuts, scribe edge of wood first with combination square; set table saw to 45° and cut 1/16 in too long, then shave to line, adjusting blade if needed Check cuts with square

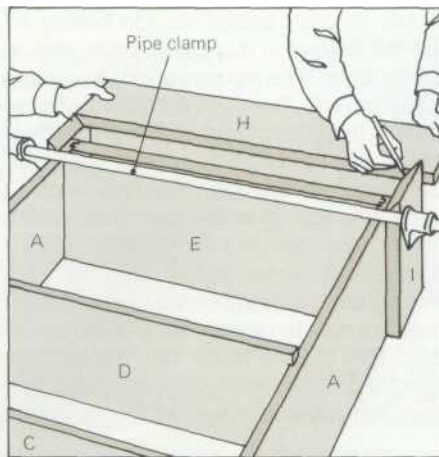

11. Clamp plinth sides (I) to shelf unit so beveled ends align with front of unit Fit plinth front (H) by holding beveled end against one side bevel and marking other end; cut overlong, then shave a little at a time until both mitered joints fit snugly Cut sides to length

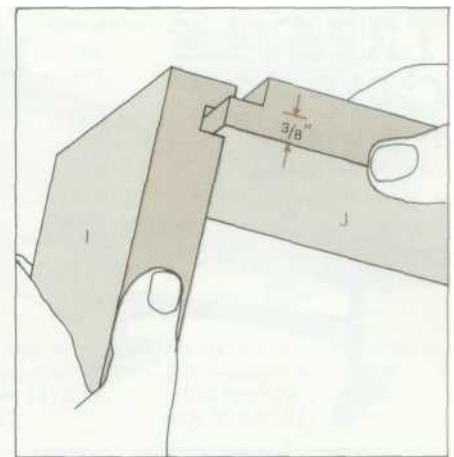

12. Rip and plane stock for plinth back (J) and spacer (K) to width of unrabbeted portion of sides. Cut plinth back to length Rabbet both rear corners, leaving tongues 3/8 in thick Mark and cut dadoes in plinth sides (I) to fit (See Steps 1 and 2.)

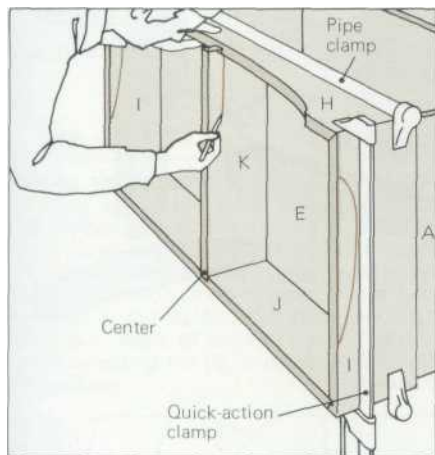

13. Cut dadoes to receive spacer 1/4 in deep across center of inner faces of plinth front and back Clamp plinth pieces in place around shelf unit and cut spacer to fit between dadoes Scribe and rough-cut cutouts on plinth front and sides and front end of spacer.

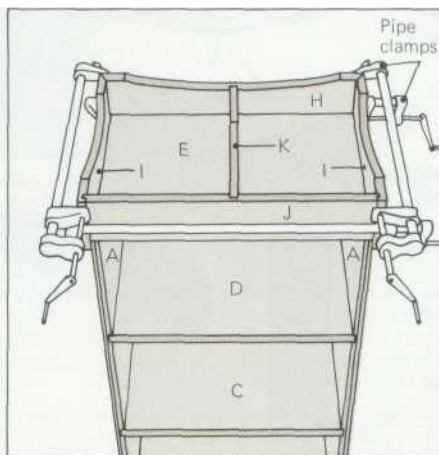

14. Rub wax on front corners of shelf unit. Then, after establishing clamping procedure with a dry run, apply a thin coat of glue to all mitered ends and clamp plinth together around shelf unit. (Put back and spacer in place for clamping, but do not glue them)

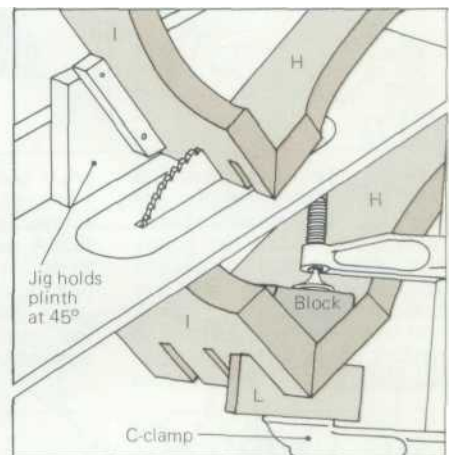

15. Dado three slots across each mitered corner, using scrap wood to set width and depth of saw. Cut splines (L) square to length of slots. Apply glue Use a C-clamp to force each into its slot When glue dries, saw splines parallel to wood surface; plane flush

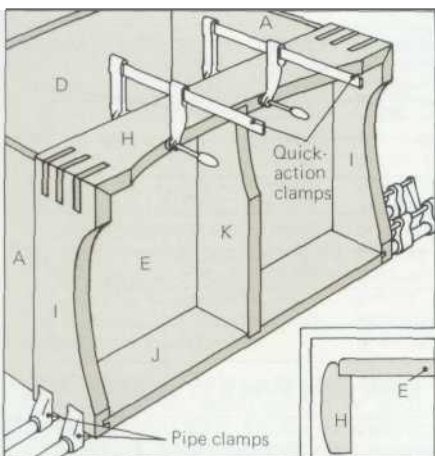

16. With rasp and sandpaper, shape inner edges of plinth sides and front, finish shaping cutout sections, and round front edge of bottom piece (E). Clamp plinth to unit, gluing tongues of back (J) into their dadoes. When dry, glue and clamp spacer (K) in place.

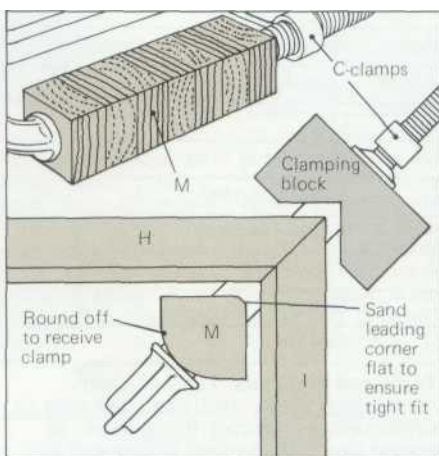

17. Glue corner block laminates (M) in stacks, alternating grain direction. Saw to lengths needed Glue and clamp into joints of plinth. When glue is dry, begin shaping plinth First, rule lines along face of front (H) and sides (I) 1 in. from top edge and 1 7/8 in from bottom.

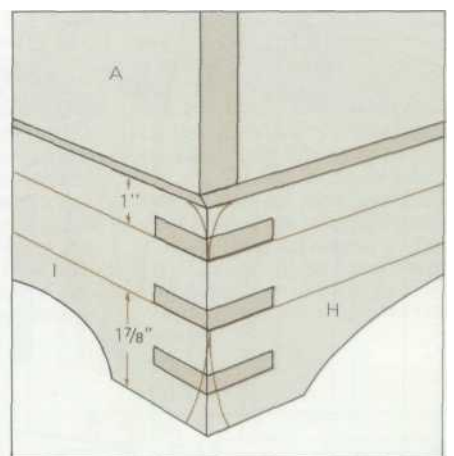

18. Trace pattern for rounding plinth onto both faces of front corners and onto rear edge Plane to desired shape Complete shaping all edges with No. 80 sandpaper, then sand with Nos 120 and 220. Finish shelf unit, plinth and back, then screw back in place