

157

BUNGALOW MAILBOX

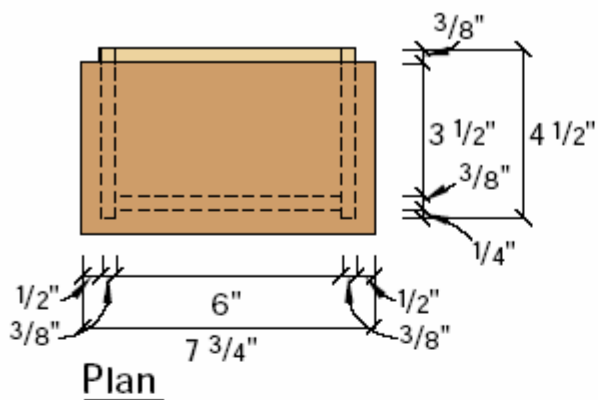



Plan

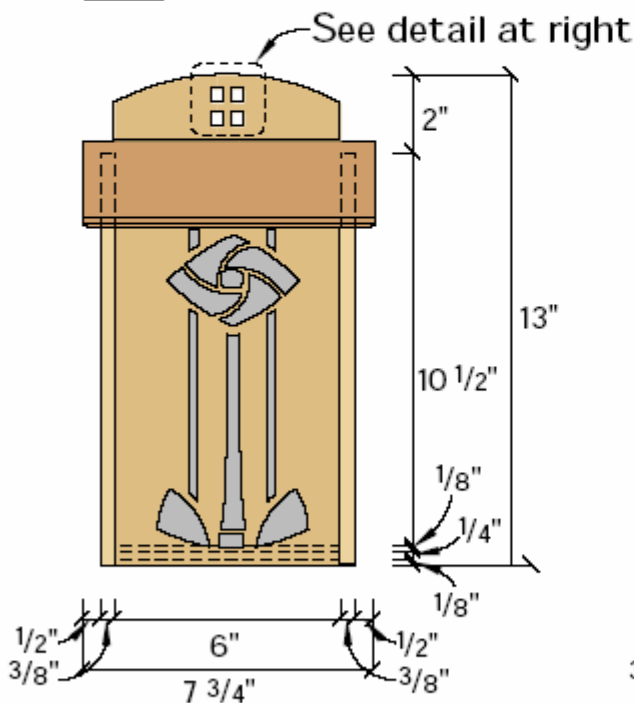

Elevation

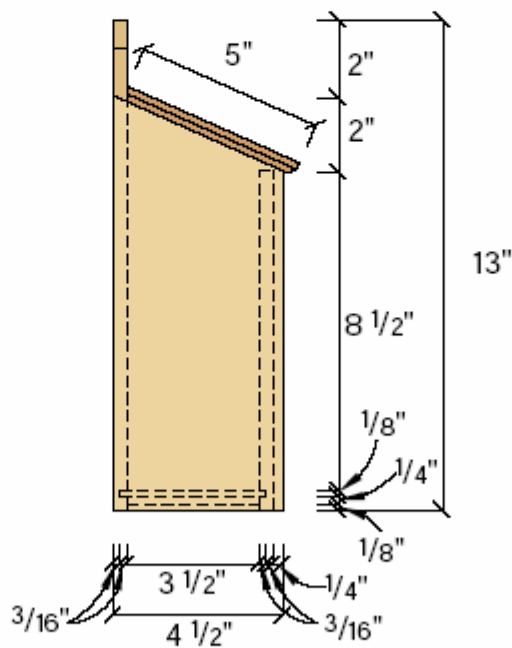

Profile

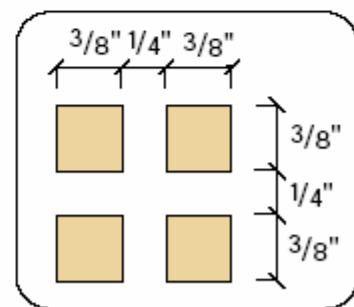

Four square detail

This project was by request. As I live in the 'burbs and have to walk to the curb to pick up my bills, a mailbox mounted next to my front door would be purely decorative. But a friend lucky enough to have postal delivery right to his door asked if I could come up with an appropriate design for his Arts & Crafts-style bungalow home.

After a little research I settled on a design reminiscent of the work of Charles Rennie Mackintosh. Arguably Scotland's greatest 20th century architect and designer, Mackintosh inspired much of the European Arts & Crafts movement during the early 1900s. A stylized flower motif is found on many of his pieces.

Mostly Glue • The joinery for the box is primarily glue and butt joints, utilizing the long grain-to-long grain orientation of the sides, back and front. The bottom, however sits in a tongue-and-groove joint between the front and back pieces to allow the wood to move.

After cutting the pieces according to the Schedule of Materials, cut a 1/4" x 1/8" rabbet on the underside of the two long edges of the bottom. This will leave a 1/8" x 1/8" tongue on the front and back of the bottom (photo one, left). Then cut the dados on the inside bottom of the front

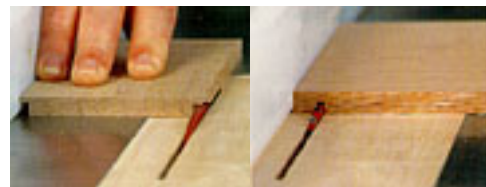

1 **BOTTOM JOINERY** • The bottom fits into the front and back pieces using a tongue and groove method. The sides are not attached to the bottom, and in fact the bottom is cut to allow a 1/16" gap on either side. Should water happen to get into the mailbox, these gaps will allow it to escape rather than pool up in the bottom.

and back pieces by setting the rip fence for 1/2" and the blade height to 3/16" (photo one, right).

Adding the Angles • Now cut the sides of the mailbox on an angle so you can attach the mailbox to your house without cramming a tool inside the box. The sides slope at a 25-degree angle with the front edge measuring 9" tall and the back edge 11" tall. Now cut the chamfer on the underside of the lid. The front and two sides are chamfered at a 45-degree angle on the table saw, leaving a 3/16" flat edge to the top of the lid. The back edge of the lid is cut at a 25-degree angle to mate with the box's back.

Detailing the Back • To add another Mackintosh feature, I cut a four-square pattern centered in the top of the curved back. First mark the location of the four-square pattern as shown on the diagram. Use a 3/8" drill bit to remove most of the waste from the squares. Then use a chisel and a triangular file to clean up the cuts. To make the curve, draw a 6" radius along the top edge of the back and cut to the mark on the band saw. After sanding, you're ready to glue up the box. The front is set back 1/4" on the sides, while the back is flush to the back edge. The bottom is left loose in the assembly. Now cut out the applied detail from 1/8" stock on the scroll saw.

Finishing Touches

Before gluing the flower to the box, stain the box a rustic-looking gray-brown by applying a black aniline dye wash. The wash was made by diluting the dye eight-to-one with denatured alcohol. I then colored the flower and stem pieces with undiluted aniline dye. Attach the flower pieces using cyanoacrylate glue. To finish, use a coat of spar urethane for outdoor protection.

The final tasks are installing a small jewelry box continuous hinge for the lid and the copper magazine hooks. I made the hooks from a couple pieces of 3/4" copper tubing. Flatten the piece with a dead blow hammer, then use a ball-peen hammer to add a dimpled, hand-hammered appearance. I then "antiqued" the copper using a product called Patina Green from a company called Modern Options (415-252-5580). The product quickly adds a nice green patina.

Now screw the two hooks to the back, and the mailbox is ready to hang.



2 TOP CHAMFER • The top is chamfer cut on three edges, and angle cut on the back edge. By moving my rip fence to the left of the blade, my right-tilt saw is able to make the cuts safely, allowing the waste to fall away from the blade.

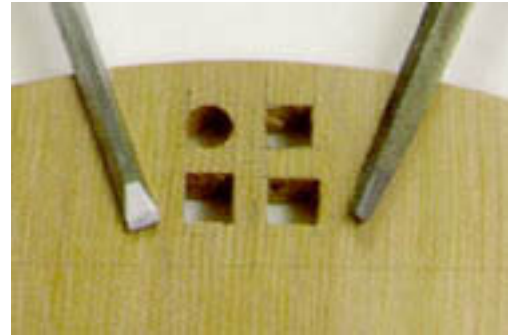

3 FOUR-SQUARE • After drilling the holes, use a 1/8" chisel and a triangular file to clean up the hole. The top left hole is shown after drilling, while the two lower holes have been completed.

Schedule of Materials: Bungalow Mailbox			
No.	Item	Dimensions	Material
2	Sides	3/8" x 4 1/2" x 11	White Oak
1	Front	3/8" x 6" x 9"	White Oak
1	Back	3/8" x 6" x 13"	White Oak
1	Bottom	3/8" x 3 11/16" x 5 7/8"	White Oak
1	Top	3/8" x 5" x 7 3/4"	White Oak
1	Applied detail	1/8" x 6" x 9"	White Oak
2 12" lengths of 3/4" copper pipe			