

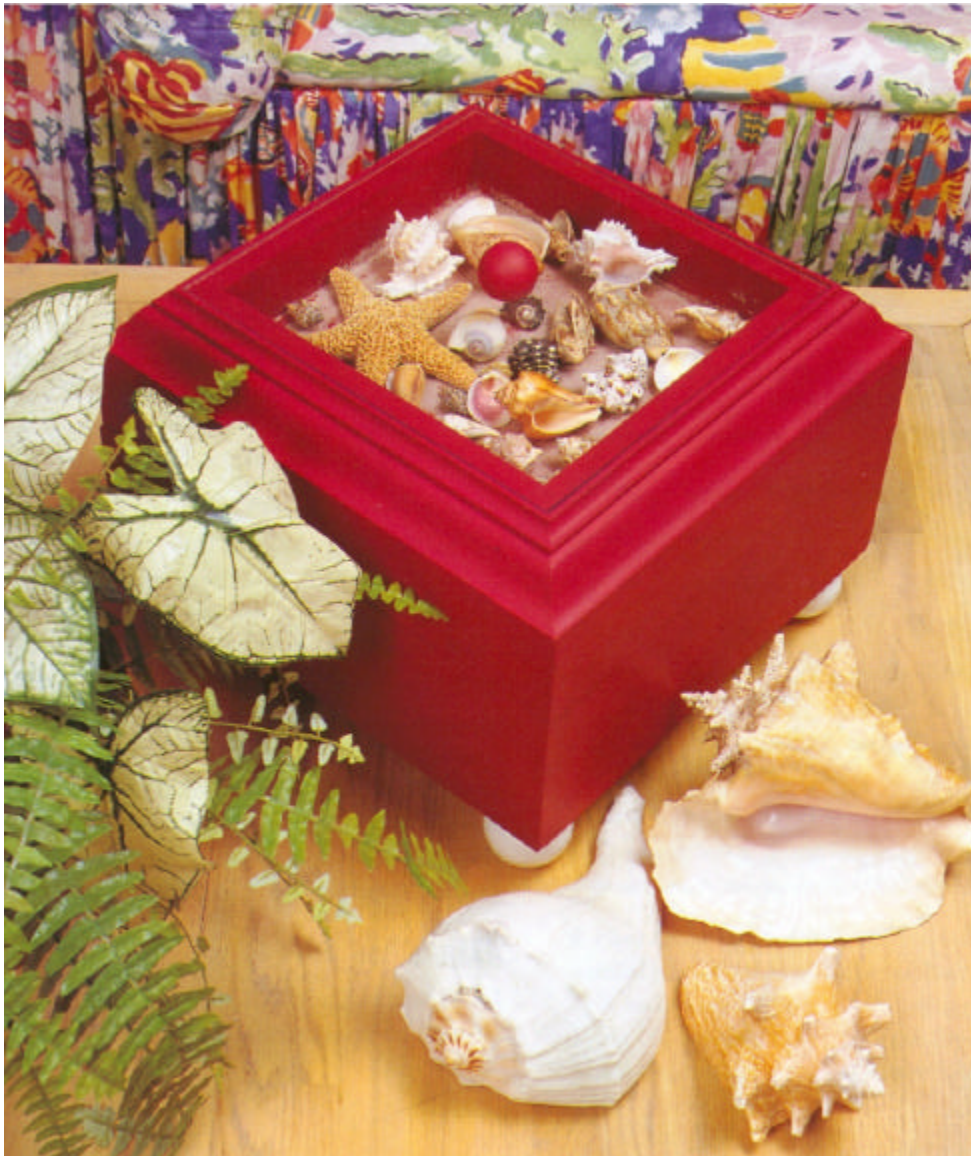

Wow! I Made It.com

## Display Box

*This great accessory is both functional and decorative. The inside space is large enough for a variety of storage purposes, everything from keeping remote controls together to serving as a jewelry Box. The piece is also useful for displaying keepsakes, such as photos, treasured collections, or (as shown here) pretty shells.*



## **Materials**

- 4' x 4' sheet 3/8" plywood
- 6 linear feet of 3-1/4"-wide crown molding
- 12" x 11-1/4" piece of clear plastic sheeting (1/8" thick)
- 4 round curtain rod finials
- 1 drawer pull

## **Hardware**

- 4, 1-1/2" wood screws
- 60, 1" 2d finishing nails

## **Special tools and techniques**

- Miter

## **Cutting List**

| Code | Description    | Qty. | Materials                 | Dimensions        |
|------|----------------|------|---------------------------|-------------------|
| A    | Lower Box Side | 4    | 3/8" plywood              | 5" x 14-3/4"      |
| B    | Lower Bottom   | 1    | 3/8" plywood              | 5-1/8" x 14-3/4"  |
| C    | Lid Side       | 4    | 3/8" plywood              | 2-1/4" x 14-3/4"  |
| D    | Lid Top        | 1    | 3/8" plywood              | 14-3/4" x 15-1/8" |
| E    | Long Top Trim  | 2    | 3-1/4"-wide crown molding | 15-1/8" long      |
| F    | Short Top Trim | 2    | 3-1/4"-wide crown molding | 14-3/4" long      |
| G    | Inside Trim    | 4    | 3/8" plywood              | 2" x 11-1/2"      |
| H    | Clear Sheeting | 1    | Plastic (Plexiglass)      | 12 x 11-1/4"      |

## **Making the Lower Box**

1. Cut four Lower Box Sides (A) from 3/8"-thick plywood, each measuring 15-1/8 x 14-3/4 inches.
2. Place two of the Lower Box Sides (A) on edge parallel to each other on a flat level surface and 14-3/4" apart. Place the remaining two Lower Box Sides (A) between the ends of the first two Lower Box Sides (A) as shown in *Figure 1*. Apply glue to the meeting surfaces, and nail the sides together using three 1" finishing nails on each joint. Nail through the face of the overlapping Lower Box Sides (A) into the end of the Lower Box Sides (A).

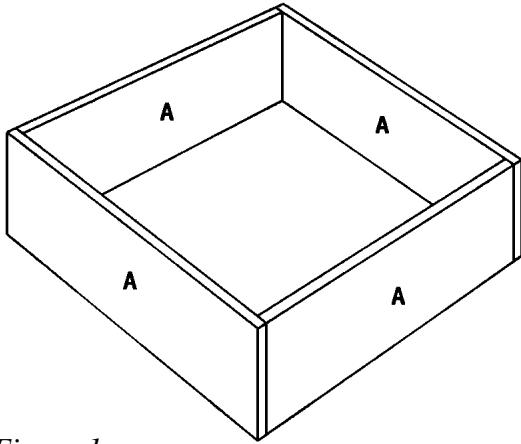

Figure 1

3. Cut one Lower Bottom (B) from 3/8"-thick plywood, measuring 5-1/8 x 14-3/4 inches. Place the Lower Bottom (B) over the edges of assembled Lower Box Sides (A) as shown in *Figure 2*. Apply glue to the meeting surfaces and nail through the Lower Bottom (B) into the Lower Box Sides (A) using five 1" nails on each side.

### **Making the Upper Lid**

1. Cut four Lid Sides (C) from 3/8"-thick plywood, each measuring 2-1/4 x 14-3/4 inches.
2. Place two of the Lid Sides (C) on edge, parallel to each other on a flat level surface, and 14-3/4-inches apart. Place the remaining two Lid Sides (C) between the ends of the first two Lid Sides (C), as shown in *Figure 1*. Apply glue to the meeting surfaces, and attach the sides together by using 1" finishing nails. Nail through the face of the overlapping Lid Sides (C) into the end of the Lid Sides (C).
3. Cut one Lid Top (D) from 3/8"-thick plywood, measuring 14-3/4 x 15-1/8 inches. Place the Lid Top (D) over the edges of assembled Lid Sides (C), as shown in *Figure 2*. Apply glue to the meeting surfaces and nail through the Lid Top (D) into the Lid Sides (C), using four 1" nails on each side.

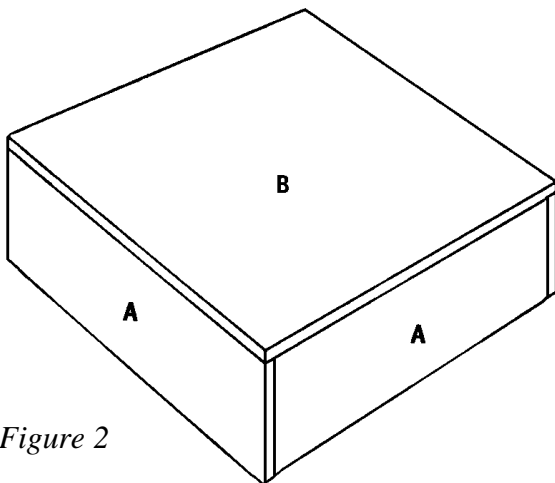

Figure 2

### **Attaching the Top Molding**

1. Place the assembled lid on a flat surface, with the Lid Top (D) facing up.
2. Cut two Long Top Trims (E) from 3-1/4"-wide crown molding at a compound 45-degree angle, each measuring 15-1/8-inches. Attach the two Long Trims (E) on the long sides of the Lid Top (D) as shown in *Figure 3*.
3. Cut two Shorter Top Trims (F) from 3-1/4"-wide crown molding at a compound 45-degree angle, each measuring 14-3/4" long. Attach the two Short Trims (F) on the shorter sides of the Lid Top (D) as shown in *Figure 4*.

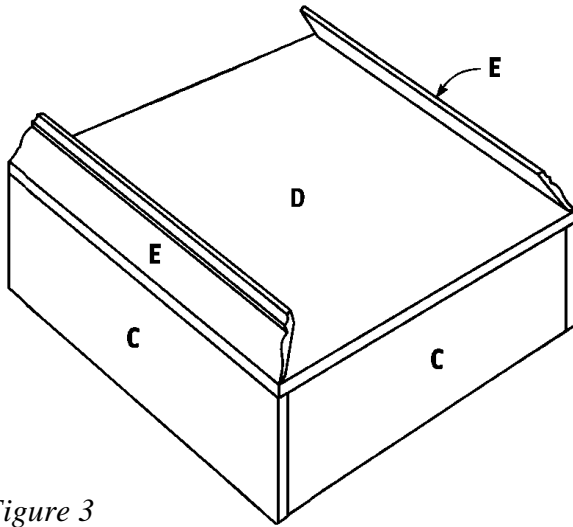

Figure 3

4. Cut four Inside Trims (G) from 3/8"-thick plywood, each measuring 2 x 11-1/2-inches.
5. Place two of the Inside Trims (G) on edge parallel to each other on a flat level surface and 11-1/2" apart. Place the remaining Inside Trims (G) between the ends of the first two Inside Trims (G) as for the Lower Box Sides (A) (see Figure 1). Apply glue to the meeting surfaces, and nail the sides together using two 1" finishing nails. Nail through the face of the overlapping Inside Trims (G) into the end of the Inside Trims (G).

6. Place the assembled Inside Trims (G) inside the crown molding frame, as shown in Figure 5. Apply glue to the meeting surfaces. The glue alone will be all that is needed to hold the Inside Trims (G) in place.

### **Adding the Feet and the Plastic Top**

1. Find the center of the purchased 12 x 11-1/4-inch clear plastic sheeting (H). Use a ruler to draw two bisecting lines, each from opposing corners, as shown in Figure 6. The center is the point at which the lines intersect. Drill a hole and add the drawer pull. Note: Don't get discouraged about which side the drawer pull should be--you can't do that incorrectly! (We tried!) If you do not plan to change the decorative contents of the box, you can seal the plastic sheets with clear silicone.
2. Place the assembled lower box upside-down on a flat surface so that the Lower Bottom (B) is facing up. Drill through all four corners the Lower Bottom (B), in the locations shown in Figure 7.

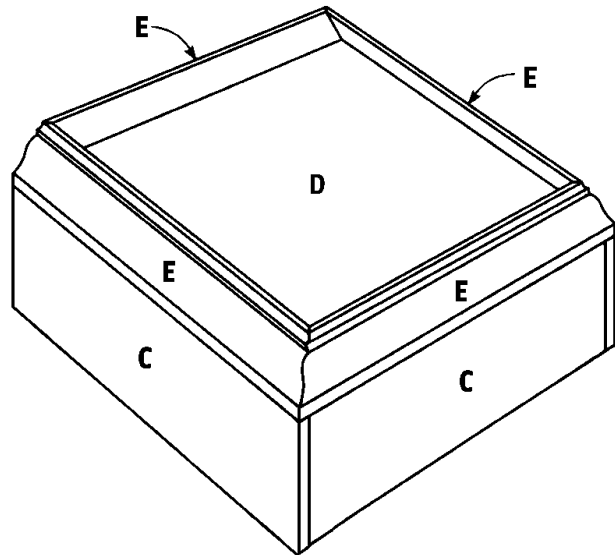

Figure 4

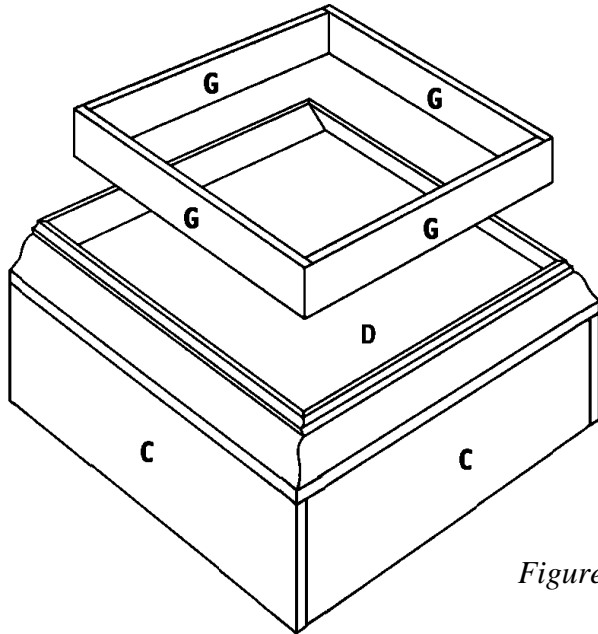

Figure 5

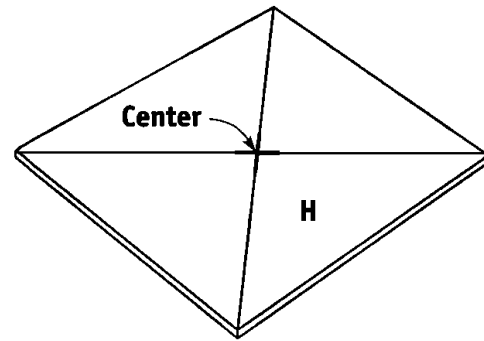

Figure 6

3. To attach the curtain rod finials to the Lower Bottom (B), screw through the inside of the lower box into the curtain rod finials (I) using 1-1/2" screws.

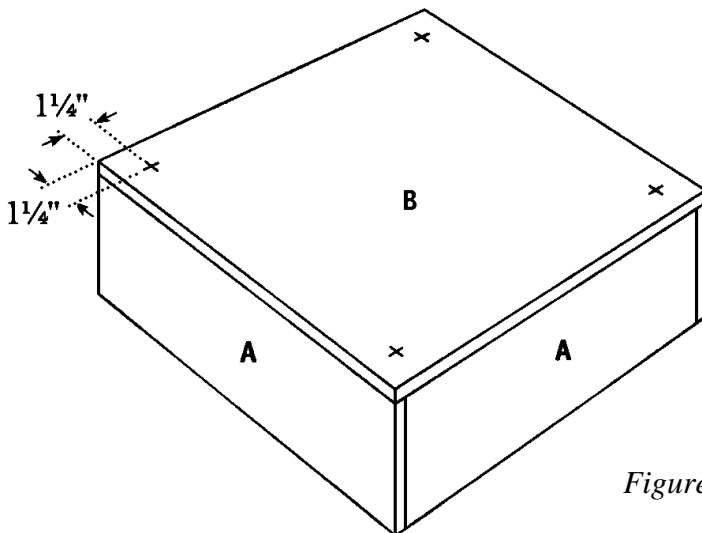

Figure 7

## **Finishing**

1. Fill any nail holes, cracks or imperfections with wood filler.
2. Sand all areas of the assembled display box.
3. Stain or paint your box the color of your choice. We chose a satin-finish maroon red paint, and painted the feet white.



---

**Enjoy many other indoor and outdoor projects from  
!**

