



Wow! I Made It.com

End Table



This simple-to-build end table is perfect for spaces next to a couch that won't accommodate a larger table. It's large enough to accommodate a lamp and books, but small enough to walk around without permanent injury to your shins. We finished our table in a dark stain to coordinate with our couch, but left the decorative trim its natural color.

Materials

- 22 linear feet of 1 x 4 pine
- 2 linear feet of 1 x 12 pine
- 7 linear feet of 3/4 inch rope molding

Hardware

- 1-1/4" 3d finishing nails
- 1-1/4" screws
- 1-1/2" screws

Cutting list

Code	Description	Qty	Materials	Dimensions
A	Top	1	1 x 12 pine	20-1/2" long
B	Front/Back	2	1 x 4 pine	20-1/2" long
C	Sides	2	1 x 4 pine	12-3/4" long
D	Wide Leg	4	1 x 4 pine	22-1/2" long
E	Narrow Leg	4	1 x 4 pine	22-1/2" long
F	Rope Molding	4	3/4" wide	Cut to fit

Building the Table Top

1. Cut one top (A) from 1 x 12 pine, measuring 20-1/2" long.
2. Cut two front/back (B) from 1 x 4 pine, each measuring 20-1/2" long.
3. Cut two sides (C) from 1 x 4 pine, each measuring 12-3/4" long.
4. Place the top (A) on a level surface. Place the two front/back (B) on edge on either side of the top (A), matching the 20-1/2" long sides, as show in *Figure 1*. Apply glue to the long edges of the top (A), and screw through the front/back (B) into the edges of the top (A), using five evenly spaced 1-1/2" screws on each joint. This joint can also be glued and clamped for an hour or so, omitting the screws.
5. Place the two sides (C) over the ends of the two front/back (B), as show in *Figure 1*. Screw through the sides (C) into the ends of the front/back (B) and the top (A), using two or three 1-1/2" screws on each joint.

Making the Legs

1. Cut four wide legs (D) from 1 x 4 pine, each measuring 22-1/2" long.
2. Rip a total of 8 feet of 1 x 4 pine to a width of 2-3/4".
3. Cut four narrow legs (E) from the 2-3/4" wide ripped material, each measuring 22-1/2 inches long.

Figure 2

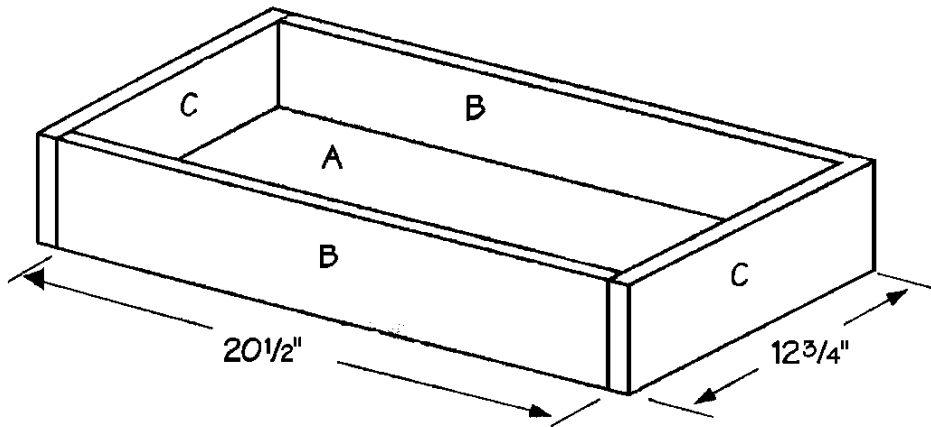

4. Attach one narrow leg (E) to one wide leg (D) as shown in *Figure 2*. Apply glue to the edge of the narrow leg (E), and screw through the wide leg (D) into the edge of the narrow leg (E), using five evenly spaced 1-1/2" screws. This joint can also be glued and clamped for an hour or so, omitting the screws. The finished leg assembly should measure 3-1/2" on each of the outside widths.
5. Repeat Step 4 three more times, using the remaining three narrow legs (E) and three wide legs (D).

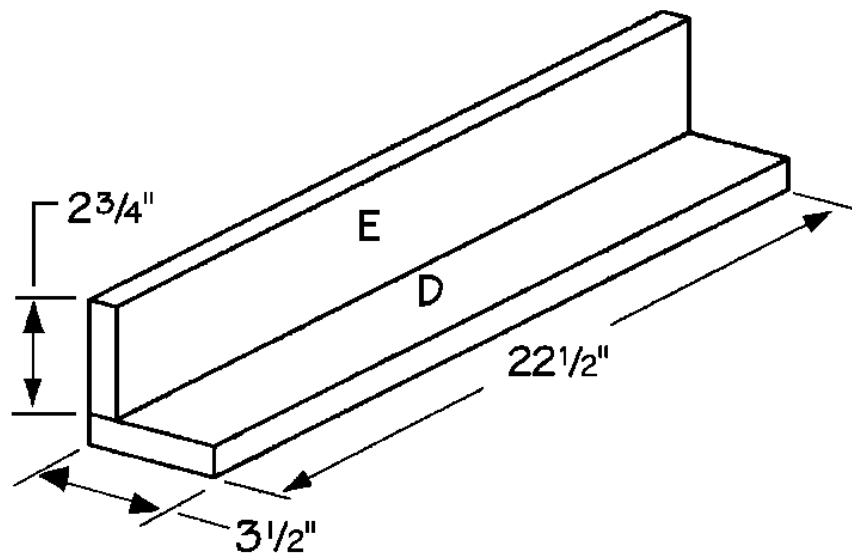

6. Place the base assembly (A and B) on a level surface. Attach the four leg assemblies to each of the four corners of the base assembly, as shown in *Figure 3*. Apply glue to the meeting surfaces, and screw through both sides of each leg assembly, using two 1-1/4"

screws on each side. After driving each screw, use a try square to make sure that the legs (D) remain at a right angle of both front (A) and side (C).

7. Measure carefully and cut pieces of $\frac{3}{4}$ " wide rope molding (f) to fit around the completed end table over the front, back, and sides, mitering the molding at each of the four corners, as shown in the photograph. Attach the molding to the end table, using glue and 1-1/4" 3d finishing nails spaced every 4 inches.

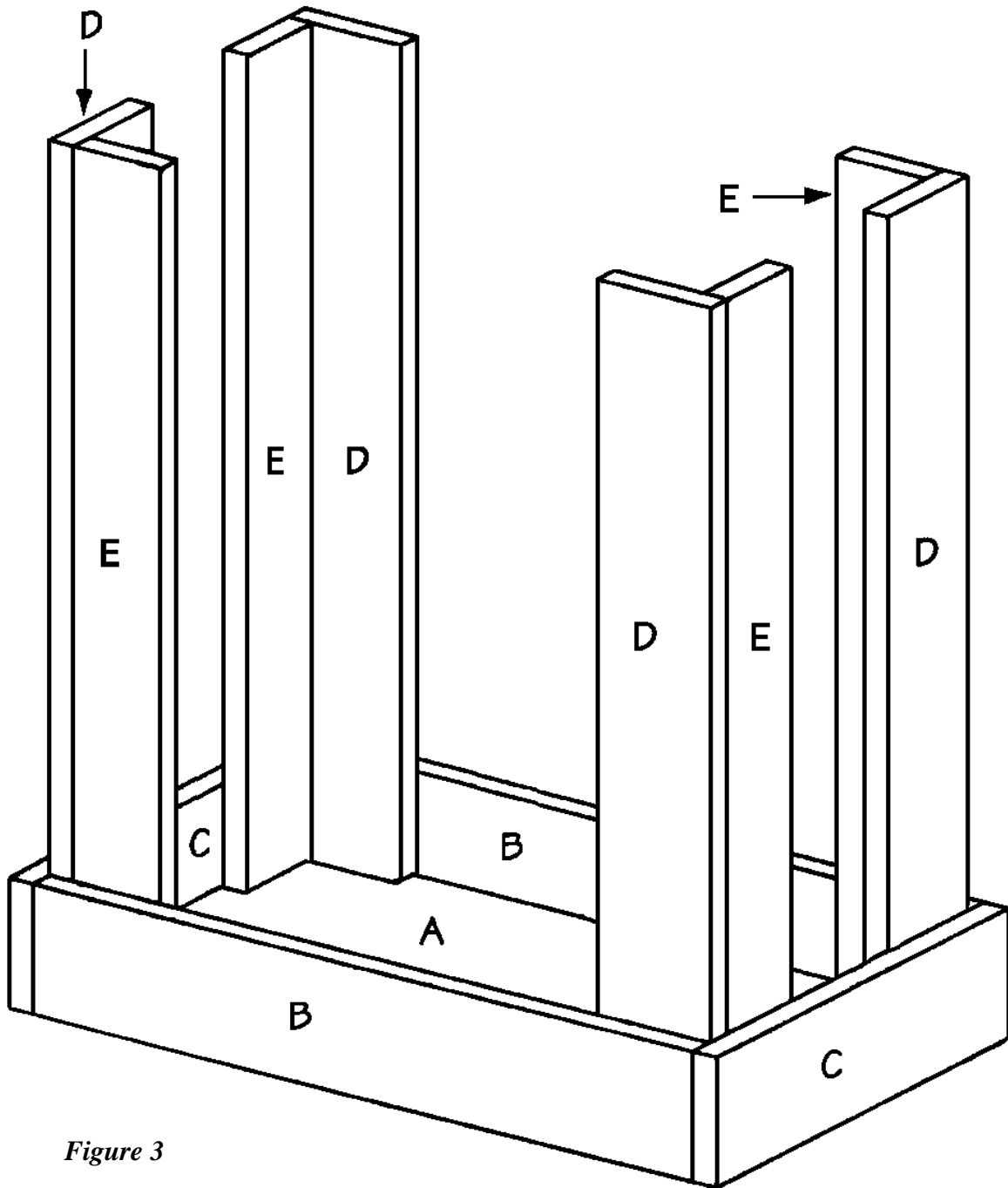

Figure 3

Finishing

1. Fill any screw holes or imperfections in the wood with wood filler.
2. Thoroughly sand all of the wood parts on the completed end table.
3. Stain or paint the table the color of your choice. We chose a deep green stain to coordinate with our sofa, but left the rope molding its natural color for contrast.

Try another project! Coordinate your room!



This photograph contains seven projects available from : Kitchen Table, Entertainment Center, Tiled Coffee Table, Corner Display Cabinet, End Table, Mirror, and Buffet. Notice how everything is coordinated, and the rooms look unified because all of these pieces are designed in a similar scale, made of similar materials, and finished with similar techniques and colors.