

Computer Workstation

Use arrows to view the project from different angles & magnifying glass to enlarge image.

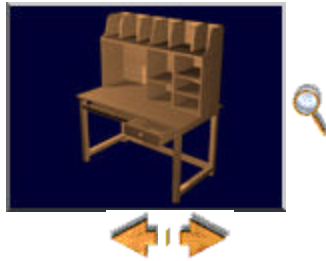

The Project

The computer workstation has become the "desk" of the millennium. But even the simplest version can cost hundreds or more at your local computer furniture store. By building our version you'll not only pocket big savings, you'll also have a strong, sturdy workstation for years to come. And, by building your own, your total cash outlay for materials for this first-class workstation will be a fraction of what you would pay for a comparable, commercially built table.

The bonus of this project is that you will learn some new woodworking techniques, such as component or modular building; that is, building sections which are later assembled to complete the piece. Additionally, this computer workstation project will help you improve certain skills you already have, such as edge-joining, design and layout. You'll also learn how to apply a beautiful finish, which will protect your project from surface damage and keep it looking its best for years to come.

Computer Workstation

Tools & Materials

Tools Required

Hand Tools

- Pencils
- Ruler (zigzag or tape)
- Square (combination or try)
- Assorted files
- Assorted dia. drill bits
- Phillips screwdriver (medium)
- Mallet
- Sandpaper, 80-grit through 220-grit
- Handsaws

- Hammer and 1/32nd nailset
- Block plane
- Hand screw clamps

Power Tools

- Plate joiner with no. 20 biscuits
- Mortiser
- Saws (band, radial arm)
- Jointer
- Sanders (stationary belt and portable belt, random orbit, pad)
- Planer
- Rasp plane
- Router, assorted cutters
- Table saw with dado head set
- Drill Press (or portable electric drill)

Miscellaneous

- C-clamps
- Bar clamp
- Safety glasses

Materials

Computer Workstation Buying and Cutting List

Key	Parts	Pcs.	Size	Material	Cut From (buy) *see Notes
A	Top	1	3/4 x 26-3/4 x 47-7/8" (OA)	Pine	4/8, 1 x 4
B	Edging, ends top	2	3/4 x 1 x 27-3/4"	Pine	All edging from 1/5, 1 x 6
C	Edging, front top	1	3/4 x 1 x 49-7/8"	Pine	"
D	Legs	4	2 x 2 x 28-1/2"	Pine	1/5, 8/4 x 6
E	Top rails, front and rear	2	3/4 x 1-1/2 x 47-1/8"	Pine	All rails from 1/7, 1 x 4
F	Top rails, ends	2	3/4 x 1-1/2 x 24-3/4"	Pine	"
G	Rear stretcher	1	1-3/4 x 1-5/8 x 47-1/8"	Pine	All stretchers cut from 1/7, 8/4 x 8" board
H	End stretchers	2	1-3/4 x 1-5/8 x 24-3/4"	Pine	"
I	Dividers	3	3/4 x 4-1/4 x 26-1/2"	Pine	1/8, 1 x 6
J	Cleat	1	3/4 x 1-1/2 x 22-3/4"	Pine	Scrap box
K	Drawer shelf	1	3/4 x 12-1/4 x 26-1/4"	Pine	1/5, 1 x 8
Drawer					
L	Drawer sides	2	1/2 x 2-5/8 x 12-1/2"	Pine	1/5, 1 x 4
M	Drawer back	1	1/2 x 1-7/8 x 10-5/8"	Pine	1/1, 1 x 4
N	Drawer front	1	3/4 x 4-3/16 x 12-1/4"	Pine	1/18, 1 x 6
O	Drawer bottom	1	1/4 x 10-1/16 x 11-15/16"	Plywood	1 sq. ft.

Keyboard Platform					
P	Keyboard platform	1	3/4 x 14-5/8 x 30-7/8"	Pine	1/5, 1 x 4
Q**	Hand rest	1	3/4 x 2 x 30-7/8"	Pine	1/1, 1 x 4
R	Stop blocks	2	3/4 x 3/4 x 3-1/2"	Pine	1/18, 1 x 6

***Notes:**

- The buying column lists the lumber in lumberyard language. Your instructor has probably already covered the subject of buying lumber; that is, that lumber is purchased using nominal dimensions, which are not the same as actual dimensions. For example, the listing (nominally) 1/5, 1 x 6 means you want one 5-ft. length of 1 x 6. The actual dimension for this board is 3/4 x 5-1/2" by 60 inches long.
- 8/4 in lumber jargon means eight quarters, or 2 inches. Bear in mind that this is the nominal dimension and that it can and will vary a bit from one sawmill to the next. Take your ruler along to make certain that the 8/4 stock you buy will allow you to plane the material to the desired 1-3/4 x 1-7/8" dimensions.
- ** The hand rest installed on the keyboard platform is shaped from a 3/4-in.-thick piece of pine. For ease of shaping this member, try to select pine without knots. See drawings for hand rest shape (profile).

Bring the above materials list to the lumberyard with you when you go to buy the materials.

Hutch Materials Lists

Note: The left-hand hutch top is referred to as L; the right-hand cabinet as R.

L HUTCH

Key	Parts	Pcs.	Size	Material	Cut From (buy)
L1	Sides	2	3/4 x 13 x 29-1/2"	Pine	2/6, 1 x 6 & 1/6, 1/4
L2	Shelf	1	3/4 x 13 x 21-3/4" (left unit)	Pine	1/4, 1 x 6 & 1/2, 1/4
L3	Back	1	3/4 x 7-1/2 x 21-3/4" (right unit)	Pine	1/2, 1 x 8
L4	Dividers	2	1/2 x 7-1/8 x 9"	Pine	1/2, 1 x 8

Miscellaneous

Table: 24 number 20 biscuits; 1/3 length 1/4" dowel, carpenter's glue, assorted finishing nails (3d and 6d); assorted grits sandpaper; one Knap and Vogt Model 1300, 16" drawer slides; one 3/4" dia. white ceramic knob with rh screw (or, pull of choice); brads; glue; two 1 x 1 corner braces; four 3-prong tack glides, 7/8" dia.

Hutch: 4 1/4-20 Teenuts® with 1-1/2" 1/4-20 fh screws; 3 3/4 x 3" mending plates with 12 1-1/4" x no. 7 fh screws; eight metal shelf clips (for adj. shelves in right hutch)

CD Box: Glue, brads, no.0 biscuits

R HUTCH

Key	Parts	Pcs.	Size	Material	Cut From (buy)
R1	Sides	2	3/4 x 13 x 29-1/2"	Pine	2/6, 1 x 6 & 1/6, 1/4

R2	Shelf	1	3/4 x 13 x 24-1/2"	Pine	1/4, 1 x 6 & 1/2, 1/4
R3	Back	1	3/4 x 7-1/8 x 24-1/2"	Pine	1/3, 1 x 8
R4	Center divider	1	3/4 x 13 x 22-1/8"	Pine	2/8, 1/6 & 1/8, 1 x 4 (for R4, 5, 6 & 7)
R5*	Fixed shelf	1	3/4 x 13 x 13"	Pine	"
R6	Bottom shelf	1	3/4 x 13 x 10-3/4"	Pine	"
R7	Adjustable shelves	2	3/4 x 13 x 10"	Pine	"
R8**	Dividers	2	1/2 x 7-1/4 x 8-3/4" (overall)	Pine	1/2, 1 x 8

- *Fixed shelf R5 is optional; install it only if you want or need it. If you do opt to install it, first check the actual dimensions of your right hutch; this way you can cut the member to custom fit.
- **Plane 3/4-in. stock to exact 1/2-in.-thickness and cut tenons on bottom and back edges as shown in drawing

CD Box Optional

Key	Parts	Pcs.	Size	Material	Cut From (buy)
CD1	Top and Bottom	2	1/2 x 5-1/8 x 12-3/8"	Hardwood*	1/4, 1 x 6 (see notes)
CD2	Ends	2	1/2 x 5-1/8 x 10"	"	"
CD3	Center divider	1	1/2 x 5-1/8 x 9"	"	"
CD4P	Back	1	1/4 x 9-15/16 x 12-5/16"	Plywood	1 18 x 18" piece, if available

Notes:

- *Since the box will be subject to heavy usage, we recommend constructing it of hardwood, such as maple or birch.
- Hardwood comes rough-dressed; make sure you select a piece that measures at least 5-1/2 in. wide, to allow for ripping to desired width. Then, plane the wood to 1/2-in. thickness.
- The CD box shown was sized to suit Kensington's QuickTrieve™ model CD Holder. These are available at better computer supplies stores. Or, if preferred, you can customize a box to suit a personal collection of CDs. If you elect to build a customized box, first be sure its outside dimensions will fit in the appropriate well of the right hutch.

Finishing Products

- [Minwax® Gel Stain, Honey Maple](#)
- [Minwax® Wipe-On Poly](#)

Alternate Finish Choices (choose one)

- [Minwax® Wood Finish™](#) and [Minwax® Fast-Drying Polyurethane](#)
- [Minwax® PolyShades® One-Step Stain & Polyurethane](#)

Miscellaneous

- Professional strength wood glue
- Paint thinner, if necessary
- Tack cloths
- Clean rags
- Water-filled metal container with lid
- Natural-bristle brush (if needed)

Before You Begin

Craftsmanship begins and ends with good work habits. Make it a habit to carefully review the plans for every project before picking up any tool or purchasing materials. Before starting this project, take time to discuss your project with your instructor: You'll avoid frustration and wasted materials.

Procedure

Construction begins with the workstation table. Be aware that the dimensions used are standard, since the aim is to create a piece of furniture that provides optimum comfort for the person working at it. The monitor and keyboard elevations are of primary importance. You may want to evaluate the most comfortable heights for working at a computer and, should they vary from the shown dimensions, make changes on the drawings so you can custom-build the table to suit your own needs.

You are advised to work with the dimensions given on the drawing, however, since these are in accord with accepted architectural standards.

START WITH THE TABLE

1. Start by cutting the 1 x 4 stock for the top slightly longer than the top's finished length.
2. Check all edges for warp, cupping and square: Board edges must be perfectly true if you are to achieve almost-invisible joints in edge-joined work. To be sure that yours will be, run all board edges through the jointer.
3. Next, lay out the boards on your worktable and arrange them so they produce the most pleasing grain appearance. At the same time, make sure you flip the boards so that the annular rings in abutting boards alternate (i.e.: The rings of the third board should be positioned the same as the rings of board number one, and, so on). Annular rings are alternated in edge-joining to further minimize chance of warping or cupping.
4. When satisfied with board arrangement for the top, using a pencil, make marks where the biscuits are to go.
5. Using a plate joiner and the marks you just made, plough the biscuit grooves to suit no. 20 biscuits.
6. Assemble the table top using glue and no. 20 biscuits.
7. Use at least three bar clamps to hold the setup securely while the glue dries. Place one near each end and the third, centered on the opposite side of the table top.
8. Allow clamped setup to dry for 24 hours.
9. The next day, remove clamps and scrape off any glue squeeze-out using a sharp cabinet scraper. Finish the smoothing step by belt-sanding the complete top; first with 80-grit abrasive, then with 100-grit.

10. Finally lay out the top for exact width and length. Using either a table or circular saw, cut the ends to produce top's exact length. Then, rip the top to its exact width on the table saw. Note that the top (at this point) is cut to the dimensions shown in the drawing-- without the edging strips in place on front and side edges. Set top aside.
11. Rip edging strips B and C to size and install them on the top using glue and 1-1/2 in. finishing nails. Use miter joints at the corners and be sure to use glue in those joints. The next day, after the glue has dried, secure the miter joints by driving a pair of opposing 1-1/4 in. brads through each mitered corner. Finally, set all nailheads slightly below the surface. Set top aside.

Cabinetmaker's Tip: When gluing up a table top, professionals never use boards wider than 1 x 4 nominal. Be aware that wider boards greatly increase the risk of warping and cupping as the wood dries, generally during the winter months or in a heated home.

12. Cut the remaining structural members for the table to size and length. Notice that the legs are a full 2-in. square. You may be required to alter the leg dimensions, depending upon what your lumberyard has in stock. If you cannot get full 8/4 stock, it may be necessary to trim the stock you have to create legs either 1-3/4 or 1-7/8 in. square.

Cabinetmaker's Tip: Do not cut any of the materials for either the keyboard platform or drawer until after your basic table is built and assembled. At that time you can take actual dimensions, sizes, etc. for these members directly from the table. This will ensure both perfect fit and minimal wasted materials.

13. Carefully lay out for the mortises in the legs. If available, use a bench top mortiser to bore the mortises in the legs. If your shop lacks this useful tool, create the mortises by boring overlapping 1/2-in.-dia. holes and cleaning the holes square using sharp chisels.
14. Lay out the stretchers (to legs) and make mating match marks where each stretcher meets a leg. (Note: Use marks that won't confuse later like I, II, III and so on.) Then mark each piece for tenon to be cut so it will mate tightly with its mating leg mortise. Carefully cut the tenons using a back saw; clean up tenons as necessary with a sharp wide chisel. Test-fit all undercarriage pieces with tenons in their respective leg mortises. Do this testing dry, without glue, before proceeding with final assembly.
15. Next, set up the table saw with dado head and rip fence so you can plough the grooves, which will receive the tabletop hold-downs. These will be ploughed in the inside surfaces of the front and back rails.
16. Because it goes a lot faster with the parts disassembled, sand all parts smooth using a belt sander and 120-grit paper.
17. Assemble the table as shown in the drawing, using glue. Working quickly, locate the dowel positions on the legs and bore the necessary holes so that the fully seated dowels will be inserted through the tenons and into the leg on the far side. Apply glue to dowels before inserting them into their holes; tap dowels home with a wooden mallet.
18. Check the table setup for square using a framing square. When satisfied with squareness, secure the carcass by tacking diagonal braces across opposing corners. Then clamp the setup so the joints will be immobile while glue sets.
19. Use appropriate-length bar clamps: You will need two with 5-ft. capacity and three with 30-in. capacity.
20. The next day, the top can be positioned on a worktable, bottom-side up, and the table undercarriage (also turned upside down) located on it. Check with a ruler to make certain the top's ends are equally distant from the end stretcher plane, and that the top's rear edge is flush at back. When the undercarriage is properly positioned, hold it that way with a

couple of c-clamps while you position and install the hold-downs with wood screws. When all is secured, remove the c-clamps and flip the table right side up.

Cabinetmaker's Tip: Though it is a basic technique, make sure you protect the wood surfaces when clamping. If your clamps do not have plastic shields, use scrap wood between clamp jaws and wood surface to prevent jaw marks from clamp pressure.

21. Cut parts I and K for the drawer compartment to size and install on the table using carpenter's glue and 1-1/4 in. screws (or air-driven 1-1/2 in. nails). (see illustration)
22. Cut the parts for the drawer and sand all members smooth, working up to 120-grit paper before assembling the drawer. Take time to study the drawing to be sure you understand how the drawer front is rabbeted; i.e., the drawer front should conceal the compartment members (parts I in illustration).
23. Lay out and bore the hole for the drawer knob in the drawer front.
24. Insert drawer into its recess and position it in the closed position. Check the front to make sure that it fits, and conceals the vertical members behind the front. Make any necessary adjustments.
25. To prevent the (short) drawer from falling out if pulled forward too vigorously, install the shaped 1/4-in. plywood stop as shown. Bore a pilot hole through the plywood. Then, hold the stop in place with a 5/8-in. rh screw. Tighten the screw until the stop can be rotated to stay in the vertical position. Finally, install the drawer and rotate the stop to the vertical (drawer stop) position, and tighten the screw a tad more to ensure it remains vertical.
26. Next, go to work on the keyboard platform. Cut the boards for it and edge-join them using glue and no. 10 biscuits. As you did for the tabletop, alternate the annular rings of abutting boards to minimize chance of warping. Apply clamp pressure and leave the setup overnight.
27. Next, lay out and install the platform's slide hardware on table and platform sides. Install the keyboard platform's stop blocks at the ends of the table-mounted slides. Note: Do not use glue on the stop blocks since you may have to reposition them in the future.
28. Insert platform into the table.
29. Push platform to the closed position to make sure it is flush with table front; adjust stop blocks if it is not.
30. Cut the piece of lumber for the hand rest and shape it using a block plane and belt sander. When satisfied with its contour, install it on the platform using glue and countersunk wood screws from below.

Except for its final sanding and the finishing steps, your table is now complete.

Optional: You may want to install furniture glides on the bottom surface of all legs to prevent (or, at least minimize) the table from rocking should it eventually be placed on an uneven floor. If you do decide to add glides, buy the 3-prong type of at least 7/8-in. dia.

Procedure - Part 2

Building the Hutch Top

The hutch top for the Computer Workstation is easier to build than the desk. However, since the upper section of this project is in prominent view, build and finish it with the same care, patience and precise workmanship that you used in building the table.

Build the hutch top in two sections; these are then joined for maximum rigidity after being installed on the desktop. By doing this, it's possible to alter the design of one or both units to suit your equipment and taste.

The hutch size, overall, is determined by two factors:

- (a) The left unit is sized to accommodate a 21-in. monitor and,
- (b) The right hutch will store computer-related paraphernalia such as CDs, floppies, notepads, etc.

As mentioned earlier, hutch sizes can be altered. If your monitor varies from 21 in. or if you want to customize the unit to adapt it for other uses or storage, you may take some liberties in its design.

Before You Begin

1. Start by cutting the boards for the legs (sides) to length, but cut them slightly longer than the finished sides will be. (In this case, that means about 30 in.) Note that each side consists of two lengths of 1 x 6 and one length 1 x 4. This will give you four stacks of three boards each which, when joined, will be both longer and wider than the required 13 in.
2. Lay out each set of three boards to achieve the best grain match for each leg and, at the same time, try to alternate annular rings on abutting boards to minimize chance of warping or cupping. When satisfied with arrangement, lightly draw a cabinetmaker's triangle across the face of each of each setup: This way each set of three boards can be quickly returned to your preferred layout of them.
3. Next, joint all edges in the four piles; check the mating edges as you go (an easy step because you have the cabinetmaker's triangle for reference) to ensure that joints will be tight and neatly matched when the boards are joined.
4. Align the first set of three boards for the first leg and carefully mark biscuit locations. Important: make sure you do not position a biscuit in the top portion of each leg area, which is shaped later; you do not want the shaping to expose a biscuit in the edge. Plough the mortises to receive the no. 20 biscuits. Then, making certain you keep the three boards together as a set, put them aside on the work bench while you repeat this procedure for the following three sides (legs).
5. Start by gluing-up the boards for the 13-in.-wide "legs" or sides. Refer to your cabinetmaker's triangle to quickly return the boards to the preferred grain layout you selected earlier. Position each set of boards as you work. For legs glue-up, you will need at least 12 bar clamps, 3 per setup. Have these, as well as the glue, a glue brush and biscuits at hand before starting the assembly step.
6. Apply glue to mating board edges and biscuits and assemble the first three boards. Ends should be aligned and boards should lie flat against bars (i.e., no bow) when clamp pressure is applied. To minimize the chance of cupping or bowing occurring when clamp pressure is applied, use a pair of clamps on one side of the boards, positioned about 4 in. from each end and one clamp at center on the opposite side. Put the clamped setup aside and allow to dry for 24 hours. Repeat assembly procedure for the remaining three sides.
7. The next day, remove the clamps and trim the four legs so all four are exactly the same size--13 in. wide by 29 in. long. Crosscut all boards to length on the radial arm saw, using a stop block to ensure all are the same length. Then, on the table saw, rip boards to width,

taking some stock off both front and back edges (this will remove any edges dented during handling, clamping, etc.).

8. Tack two of the legs together for the right hutch (R1) and two for the left (L1) after aligning each pair so all edges are flush. Hold them that way for the shaping which follows, using a half-dozen or so 1-1/4 in. brads driven flush.
9. Refer to the drawing of the shaped top, shown on 1-in. squares in the drawing, to make a template of 1/4-in. hardboard or plywood. When satisfied with template's layout, cut it out using saber or scroll saw. Sand the cut edge smooth.
10. Use this template to trace the shaped tops to the two pairs of legs you previously tacked together. Cut out the shape using saber or scroll saw.
11. Sand the scroll shapes smooth using either a spindle or drum sander chucked in the drill press.

Note: Since the dividers used on the fixed top shelves repeat the symmetry of the scroll shape used on the legs, set the scroll template aside for reuse later. When you come to make the dividers, you can simply refer to the drawing for shape then re-cut the template for use as a divider template.

12. Repeat the board layout and edge-joining steps to make all the shelves for your two units both finished and adjustable. All of these should be slightly oversize overall when they're glued-up; they will be trimmed to fit exactly after hutch units are assembled.

Cabinetmaker's Tip: You can edge-join the boards for both hutch tops in a single session as long as you use identifying marks. Make marks lightly with a soft pencil on the back edges of boards. (Use R for right cabinet; L for left.)

Cabinetmaker's Tip: Since you have cut your boards so that each side (leg) setup will be slightly oversize when assembled, there is no need to place scrap blocks between the clamp faces and wood (to prevent marred edges). Board lengths and widths will be trimmed in the next step, and clamp marks will be cut off.

Note: The following instructions take you through the steps for building the left hutch, the one that houses the monitor. The same construction steps are used to build the right hutch except for the addition of the adjustable shelves. The required steps for installing these are explained below.

13. Before laying out the shelf dados on the legs for the left hutch, measure the monitor that will be used on your workstation. Everything begins with that dimension. Make sure that the distance from leg bottom edge to bottom plane of dado provides adequate clearance for your monitor's height. (Your monitor size determines the fixed shelf location in the left hutch.) You will have to alter the right hutch dimensions so the two fixed shelves remain in line. Also, if the left hutch width dimensions are altered, the right hutch must be adjusted a corresponding measurement so that the hutch sits on the table with a 1-in. setback from table edge, left and right.
14. Since the legs (L1) for the unit have already been sized (step 7), you can now lay out the dados to receive the fixed shelf (L2).
15. The dados for the fixed shelf should be perfect mirror images in left and right legs, so make sure the legs will be exactly opposite each other in the finished cabinet. Here's how to do it:
16. Position the two legs on your worktable back-edge to back-edge and clamp them so they cannot move.

17. Lay out for the dado to be rabbeted in both legs and plough it using a 3/4-in. straight router cutter set to a depth of 3/8-in.

Cabinetmaker's Tip: On work such as this, where there is no room for error, you must always use a guide when ploughing with a router. Be certain you clamp on a guide which puts the router cutter right on the mark. Hold the router shoe firmly against the guide as you cut and, to further minimize chance of a cutting error, push the router with a slow, easy-to-control feed rate. To be extra safe, you can clamp a guide so both sides of the router shoe will be guided and to eliminate any possibility of the router "walking" off the cutting mark. If you opt to cut your dados using the table saw, make certain you use a miter gauge hold-down to prevent lateral movement of the work piece as the saw blade does its cutting. You must use a stop to position each workpiece accurately before it is pushed into the spinning blade. This ensures that the dados in both legs are positioned the exact distance from the leg end. If you have never done repetitive crosscutting on the table saw, discuss this step with your instructor before proceeding.

18. Next, insert a 3/8-in. rabbit cutter in your router and plough the blind rabbets in the back edges of both legs to receive the back (L3).
19. Assemble the two legs, fixed shelf and back without glue so you can check all for fit; use small (1-1/4 in.) brads if necessary to temporarily hold the parts together so you can do your visual check. Now lay out for the 5/16-in.-wide dados that will hold the dividers used in the fixed top shelf. Mark both the shelf and the back at this time.
20. When satisfied with fit, disassemble the hutch and abut the fixed shelf and back with the marks for the dados lined up. Clamp the boards together so they will not move and, starting at the back edge, rout the dados across, stopping shy of the front edge in order to create the blind dado as shown in the drawing. After routing, the front round corner can quickly be made square (to receive the divider) using a sharp 1/4-in.-wide chisel.
21. Reassemble the hutch using glue and fasteners of choice. Note: Because of their superior holding ability, you can use pneumatically driven 1-1/2 in. nails to join parts here. These are driven slightly below the surface and the indents can be filled with Wood Filler. Or, if preferred, 1-1/2 in. fh wood screws which are then covered with dowel plugs. If you opt for the latter, remember that you must lay out for the screw pilot holes - for body, shank and counterbore - before you start the assembly step.
22. With left hutch complete, stand it upright on the workstation table, flush at back and with approximately 1-in. setback from the left table edge. Then, measure the distance from the outside plane of the right leg to the same width setback at the right table edge. This measurement is the outside (i.e., overall) width dimension of your right-hand hutch. As stated earlier, this measurement may differ from our drawing depending upon how the left-hand hutch is sized. If there is variance with the plan drawing, now is the time to calculate all dimensional changes and to mark them on your drawing--before starting any work on your project wood for the right hutch.
23. The right-hand hutch is constructed using the same procedure as for the left--except for two steps you must take before assembly: a) The holes for the adjustable shelves should be laid out and bored; you won't be able to fit a drill between legs R1 and R4 after the unit is assembled. And, b) the dado for the middle leg (R4) must be routed in the underside of fixed shelf. Attempting this after assembly could result in damage to shelf legs. When the right unit is complete, set it atop the table abutting the left unit. Recheck both the left and right setbacks, the tabletop reveal, to make sure the left and right legs are equally distant from table edge. If the distance varies, even slightly, move units left or right to achieve that goal.
24. When satisfied with their location, position a pair of handscrew clamps on the legs at center to hold the two units together. With a pencil, lightly mark the front corner of both the left

and right (outside) legs and make match marks on tabletop. Next, carefully locate the points and make marks on both the tabletop and the legs to indicate where you must bore the holes to receive the dowels, which serve as keepers when the unit is assembled. Note that this is back about 1 in. from front edge of vertical and centered on leg width.

25. With handscrew clamps still in place, lay out for the Teenuts® to be installed on the middle legs. The fastener's locations aren't critical but, for the sake of craftsmanship, they should look precisely placed. Then bore the needed holes.
26. From the left side (i.e., the monitor's hutch), start by boring the large dia. holes to suit the Teenut, to 1/2-in. depth. Then insert a 5/16-in. bit and bore through at center of each counterbore to receive the machine screw.
27. Then switch to a countersink and, in the right hutch, countersink all four holes to receive the machine screw head.
28. Tap the Teenuts in place and secure them with the machine screws.
29. With the hutch unit still aligned on the table, position the mending plates on the three legs; one on each outside leg and the third on the center leg. Mark the four screw hole locations for each plate. Bore all screw pilot holes but do not install the mending plates as yet.
30. Carefully tilt the hutch back until it is fully supported and resting on its back. Next, bore the 3/8-in.-dia. holes in outside legs and the table top to receive the keeper dowels. Then, glue the dowels into the legs so just about 3/4-in. of dowel protrudes. Glue is used in the one side only so the hutch can be lifted off whenever necessary (i.e., for a move).
31. Wait one day, to make certain dowels are permanently affixed into the legs, then, bring the hutch to the upright position and insert the dowels into the mating holes in the table top. Now you can install the mending plates using the screw holes you bored earlier.
32. Your Computer Workstation is now complete. We also give instructions for an optional box which can be used to hold CDs close at hand. You may, however, prefer to custom design a box to suit the "extras" you frequently work with. In this case, the box shown here is a good starting point for your box.

Note: Leave your workstation assembled until you have completed constructing all the peripheral parts (CD holder, dividers, etc.), because you want to be able to test fit these pieces before finishing the table. When satisfied all parts fit as they should, you can disassemble the hutch and table to simplify the finishing step. Be sure to save all of the hardware and fasteners in a covered container so you won't have to hunt for them when it is time to reassemble your workstation.

Procedure - Part 3

Dividers for Top Shelves

To ensure the wood in the dividers matching the wood used in the workstation, we planed 3/4-in. stock from the same pile to 1/2-in. thickness, then created tenons on the bottom and back edges (see below). You could use 1/4-in. plywood here and save a little work, but because of the exposed ply edges, the finished look will not be nearly as handsome.

Since the table saw is used to remove a scant amount of material from the divider stock to create the tenons, read the Cabinetmaker's Tips below to learn the safe way to do this.

Here are the steps for making the dividers:

1. Cut the 1/2-in. stock to the divider size given in cutting list.
2. Next, to work production-fashion, align the edges of the four pieces. Then, while holding them fast, drive three 1-in. brads through the pile.
3. Using your previously made pattern, trace the divider's scroll shape onto the top work piece.
4. Cut all four at one time using the bandsaw.
5. Sand all edges smooth using the stationary belt sander along the straight edges and the spindle sander for the scroll shape. Lacking a spindle sander, chuck a sanding drum in either portable drill or drill press.
6. Separate the pile, remove and discard nails and set dividers aside.
7. Set up the table saw so you can safely remove about 1/8-in. from both sides of each divider, along the bottom and back edges. See Cabinetmaker's Tips, below. Note: The exact thickness to remove will be determined by the actual thickness of your stock and the width of the dadoes ploughed in shelf and back. The tenons you create on the dividers must fit freely in those dadoes.

Cabinetmaker's Tips: Never lay out a shape on your project wood; always make a template or pattern first. You can use either 1/4-in. hardboard or plywood--or even sturdy cardboard. Lay the shape out on your template material following the pattern given in the plan. Cut it out using saber or scroll saw (or razor knife if template is cardboard). File and sand all cut wooden edges to remove "whiskers" before using the pattern to transfer the shape to your project wood.

When a small, identical amount of wood must be removed from a number of surfaces, the most accurate technique is to set up the saw so that the waste is between the blade and fence. That is the case here, where approximately 1/8-in. is removed from both sides of the bottom and back edges. This creates tenons to fit in the dadoes provided for them. However, whenever the saw blade is this close to the fence, there is very real risk of the blade engaging the metal fence: this can be dangerous at worst, blade damaging at best.

For safety, always install and work with a wooden auxiliary fence whenever you are faced with doing this type of cutting on the table saw. In order to cut the dadoes on the 7 x 9-in. dividers, make an auxiliary fence from a length of 1 x 6." Line the board up with the rip fence and with an awl, make prick marks through the holes on your fence. Use 3/16-in. dia. fh machine screws and wingnuts to secure the auxiliary fence to rip fence. Caution: Make certain the screw heads are perfectly flush with the wood's surface when the board is secured tight against the fence by the wingnuts: the work piece must be able to slide past without interference when you make your cuts.

If you have never installed and worked with an auxiliary fence on a table saw, make sure you discuss the setup with your teacher before its installation and use.

The CD Box

The box shown in the plan was built to house a commercially available plastic CD box ([see Materials list](#)). Slotted plastic sheets are created for CD storage. Many mail order woodworker's supply houses offer these. They are available in both end and center CD holder configurations and are installed using polyurethane glue. If you want to build a custom CD box, make sure the box (i.e., its overall dimensions) fits in the right-hand hutch.

Making the Box

1. After cutting all parts to sizes shown in drawing, sand them smooth starting with 100-grit and finishing with 120-grit abrasive paper.

2. The corners are mitered and held secure with no.0 biscuits. Or, if preferred, you can use splines. Here, simply pass the miter faces through the table saw blade to a depth of about 3/4-in. and join the mitered corners using 1-1/2 in.-wide splines. If you opt for the latter technique, you may want to cut thin strips of molding to glue on the front edge to conceal the splined corners.
3. The back is of 1/4-in. cabinet grade plywood; install it using glue and 1-in. brads.

Finishing

Read through all instructions on the can labels. This holds true no matter what finish you decide to apply. There are a number of finishes available that produce professional-looking results. We recommend using [Minwax® Gel Stain](#) for this project.

Working with Gel Stain

1. Minwax® Gel Stain is a smart choice for this project because the stain provides rich, even color and will not drip or run on vertical surfaces. Check all surfaces for smoothness and, if any rough spots are found, sand lightly with 150-grit paper. Dust and wipe with a tack cloth.
2. Start with the tabletop surface, since Gel Stain is great for evenly staining large areas at a time. Apply the stain liberally with a clean, lint-free application cloth that is saturated with stain.
3. Wait 3 minutes and, using a clean rag, wipe in the direction of the grain to remove excess. If a richer color is desired, apply another coat after 12 hours.
4. Repeat the above steps for the balance of your table, staining just a manageable area at a time.
5. When the table is stained, move on to the hutch tops and CD box.
6. Set the entire unit aside to dry overnight.
7. When the unit is dry, apply a protective topcoat such as [Minwax® Wipe-On Poly](#) or [Minwax® Fast-Drying Polyurethane](#)

Computer Workstation

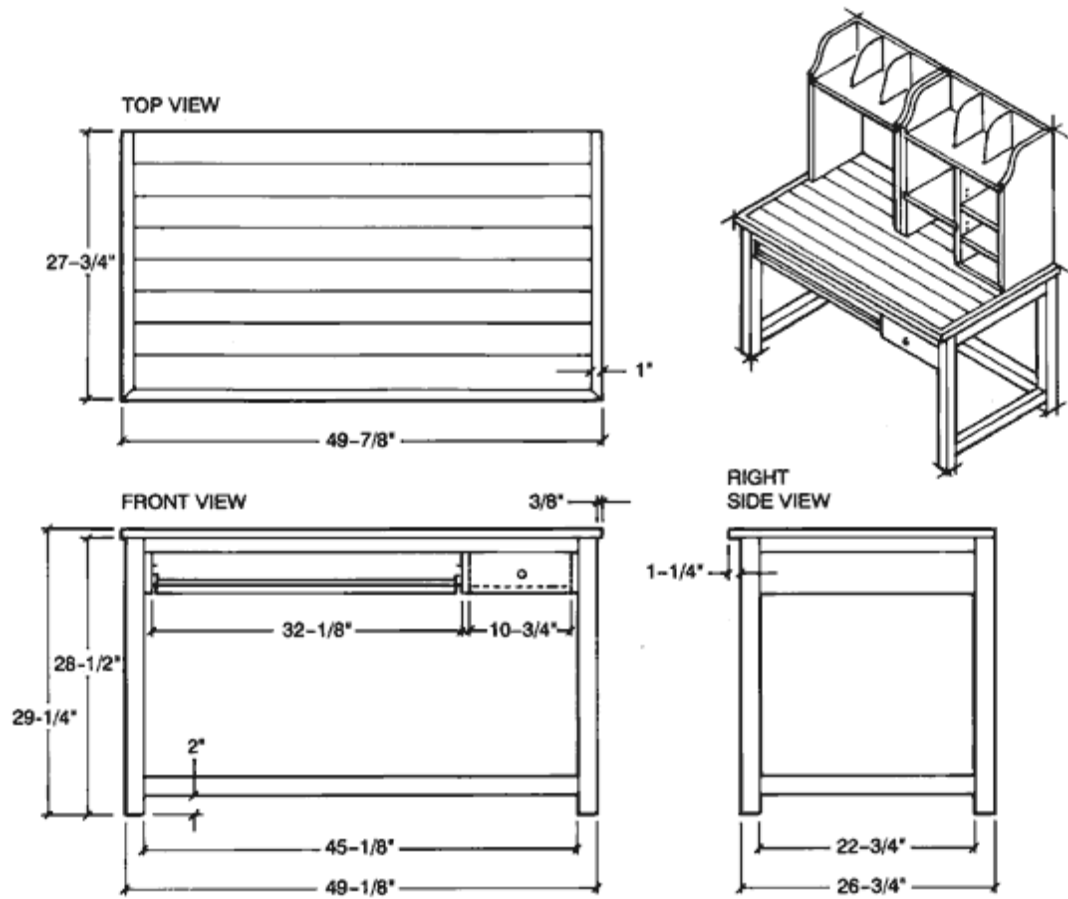

Computer Workstation

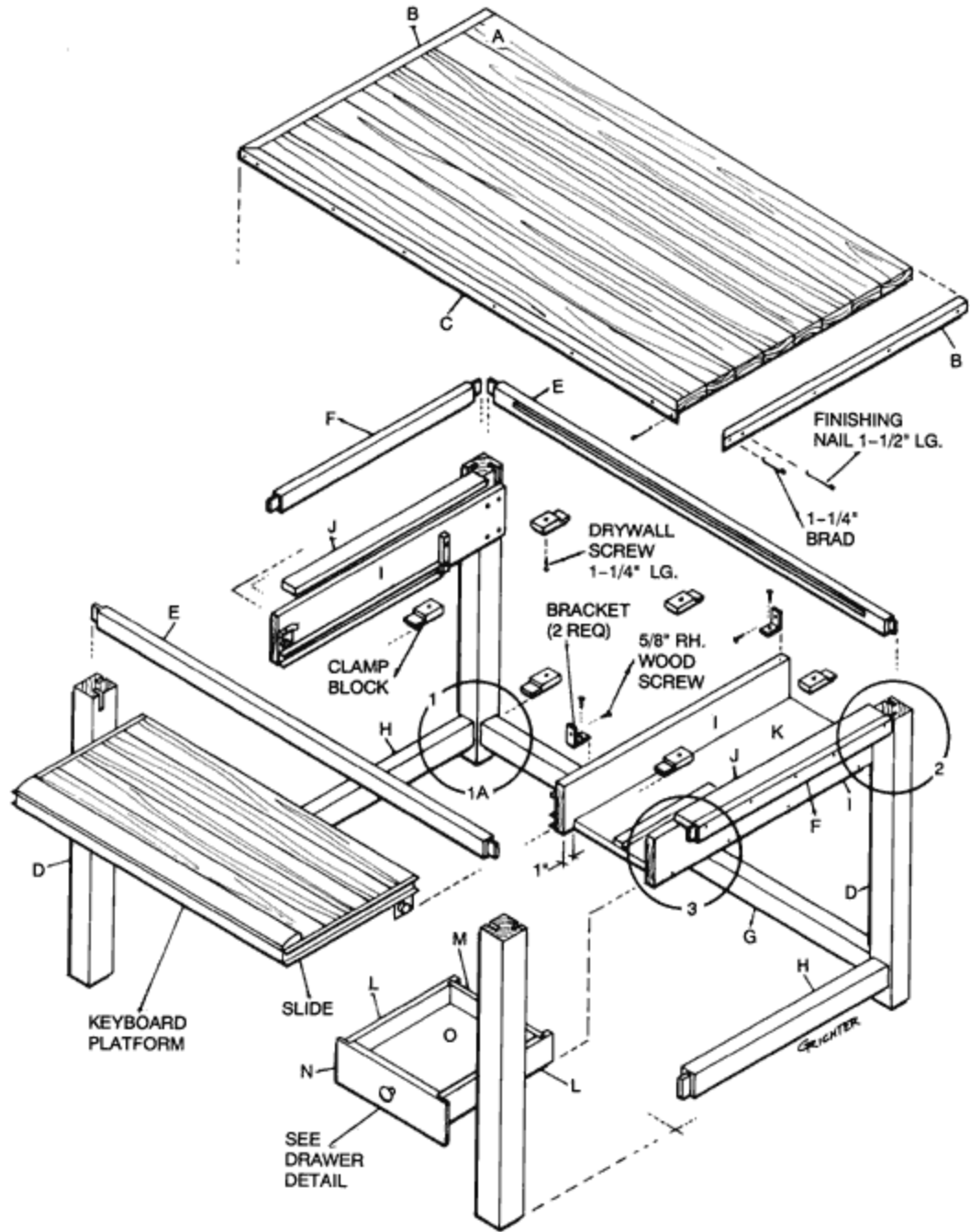

Computer Workstation

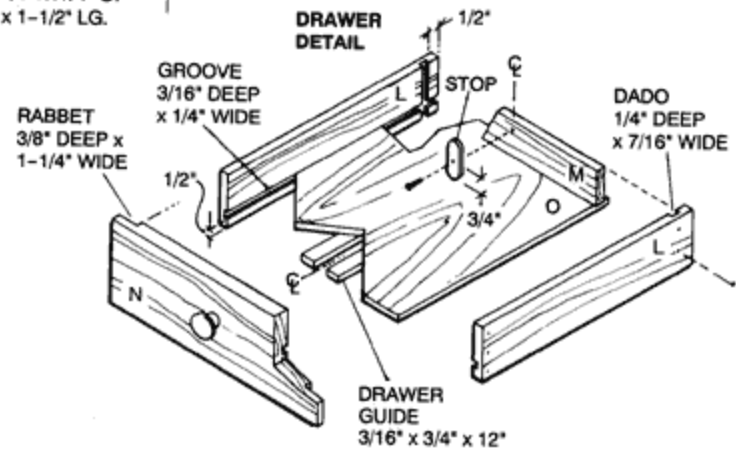
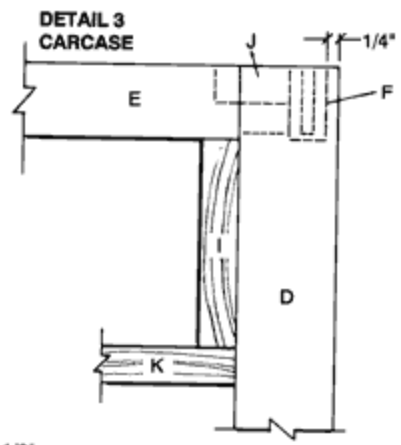
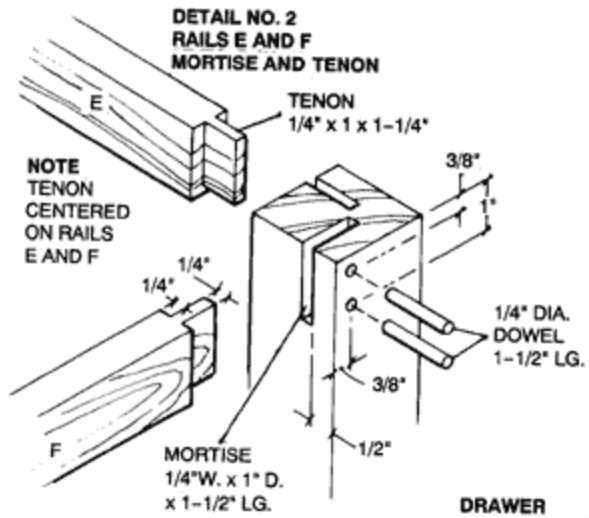
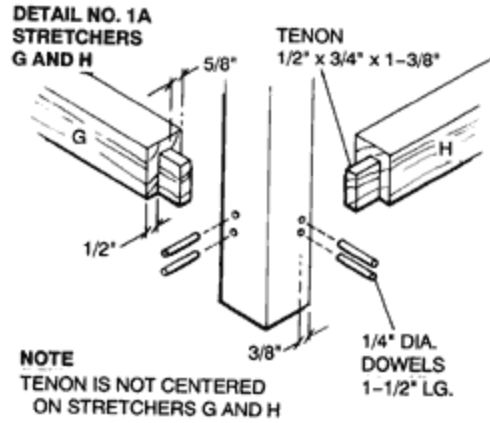
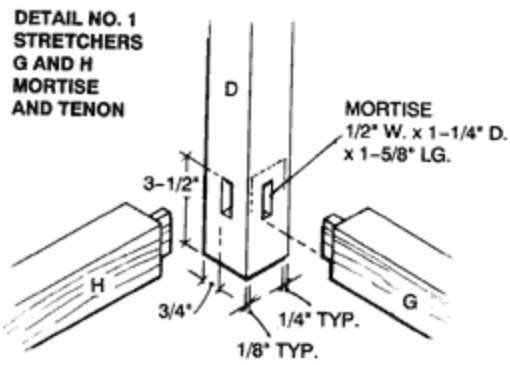

Computer Workstation

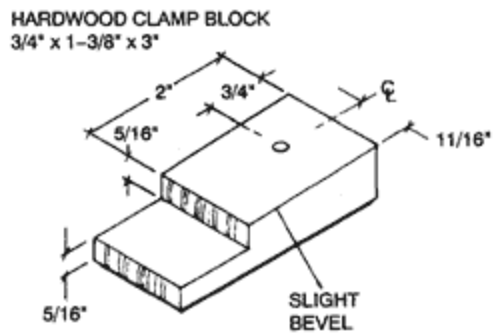
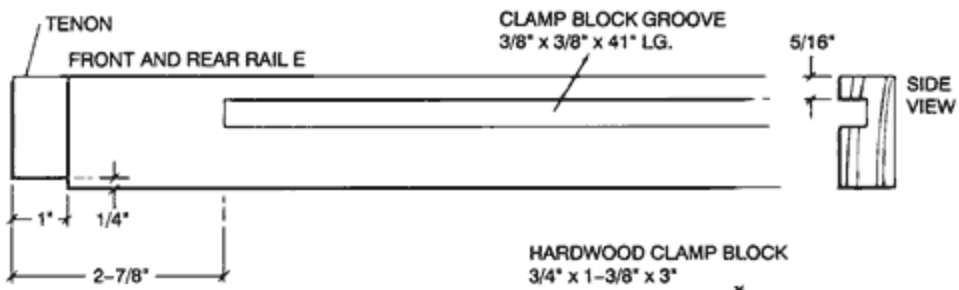
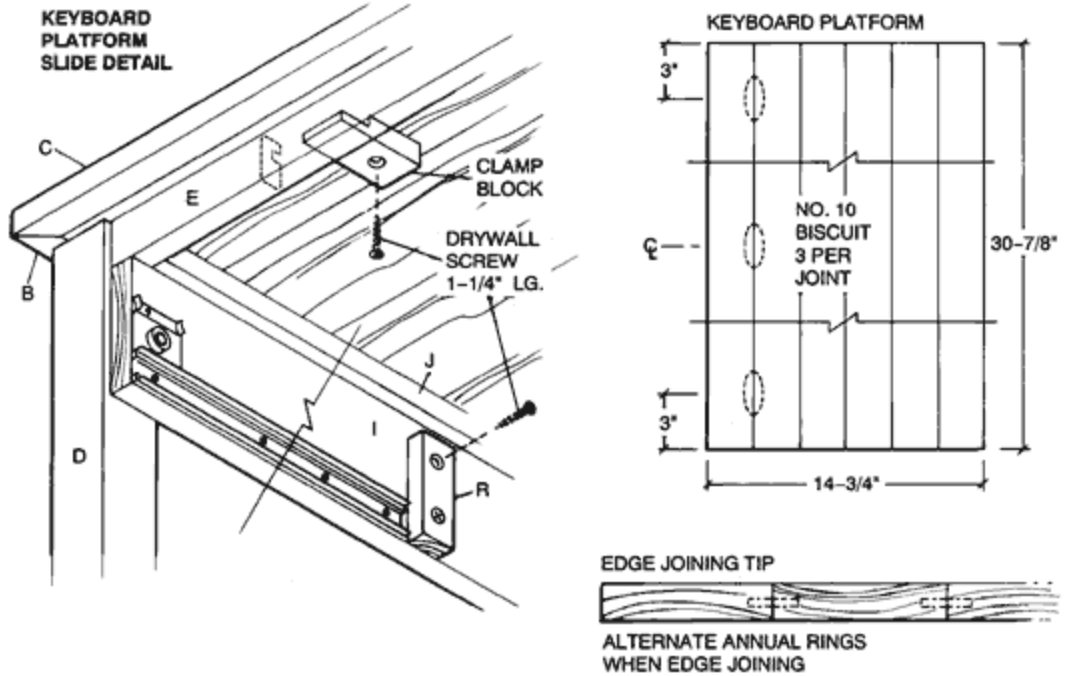

Computer Workstation

COMPACT DISK BOX

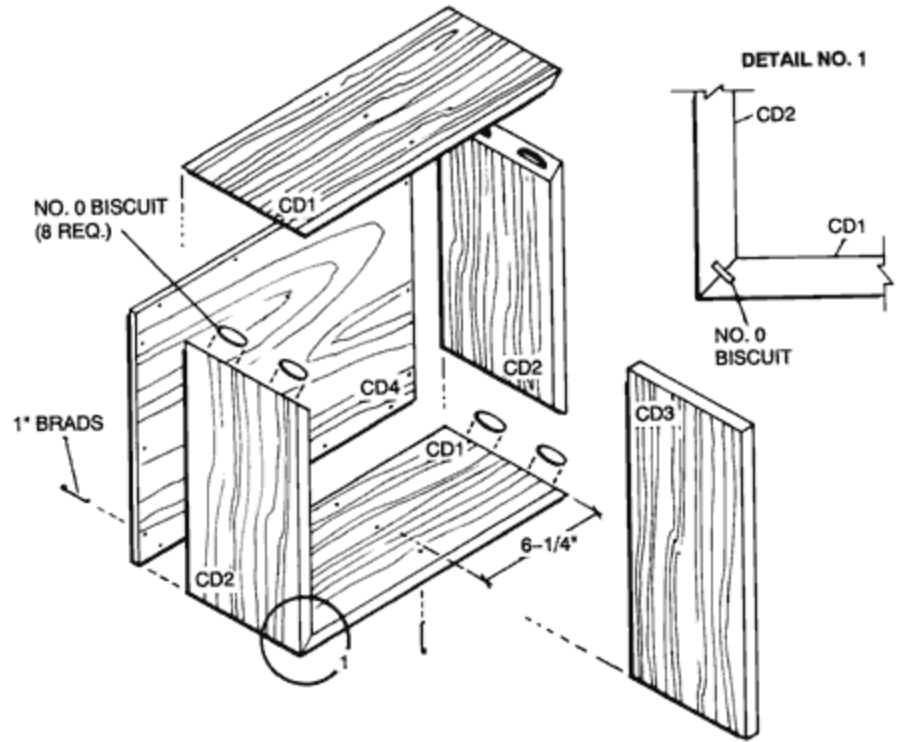

Computer Workstation

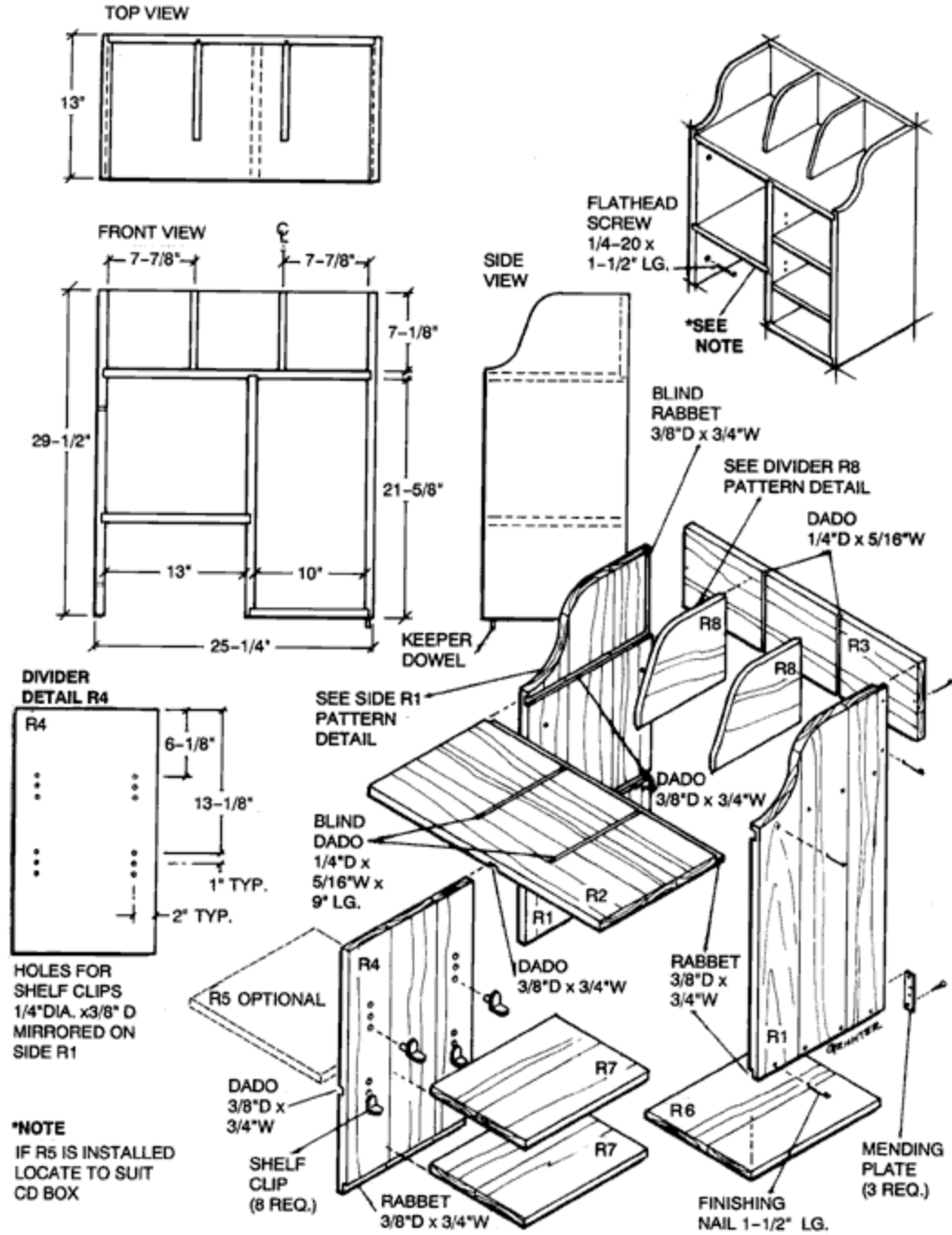

Computer Workstation

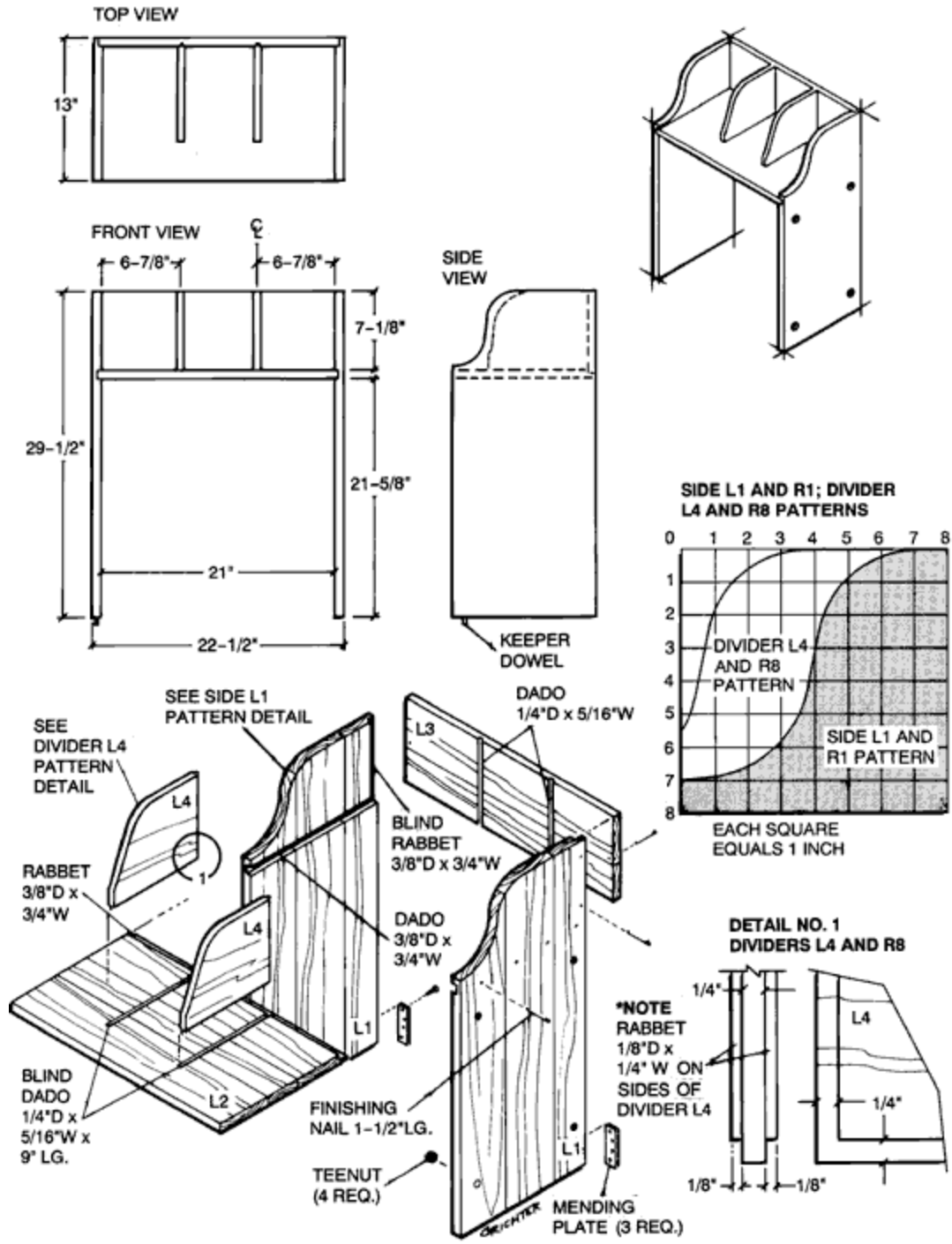

Computer Workstation

Tips Summary

- You can slightly round or "break" sharp edges on raw wood by using 100-grit paper in the pad sander. For a more pronounced rounding-over, round the edges with the router and a 1/4" rounding-over bit.
- Sand raw wood to at least the 150-grit level. Use even higher grits for hardwoods such as walnut and birch.
- All stains and finishes should be allowed to dry thoroughly between coats.
- Sanding between coats should be done with 220-240 grit sandpaper.
- Apply water-based finishes, such as [Minwax® Polycrylic®](#), with quick, with-the-grain strokes.
- To lighten or customize any wood tone to suit a personal preference, thin the stain of choice with [Minwax® Wood Finish™](#) Natural, per label instructions. In general, you will achieve your desired tone by mixing two parts of the Wood Finish™ stain color with one part of Wood Finish™ Natural. To be safe, always test your stain on scrap stock before applying it to your project wood.

Cleanup

If you have product left over, wipe the can rim to remove all product in the rim. Liquids left in the rim can dry out and prevent the lid from forming a tight seal.

Clean all brushes used for oil-based finishes with mineral spirits.

Safe Disposal of Rags & Waste

Please be mindful of the safe way to dispose of used wrap and other waste. Remember that rags, steel wool and other waste soaked with oil finishes, mineral spirits, and turpentine may spontaneously catch fire if improperly discarded.

Always place these items in a water-filled metal container immediately after use. Tightly seal the container and then dispose of it in accordance with local fire regulations. Be sure to keep the container out of reach of children.