

Weekend project

Swing into summer

Sunset's swing to build is big enough for two

The languid, back-and-forth rhythm of a swaying swing slows time on a lazy summer day. From this vantage point, you can sip a cool drink, watch neighbors stroll by, read quietly, or enjoy the hushed tones of shoulder-to-shoulder conversations. Whether it hangs from the sheltered confines of a front porch or off the branch of a backyard tree, our swing is sure to transport you away from the hurried pace of your work day.

The high-backed swing hangs securely from sturdy, $\frac{5}{8}$ -inch-diameter nylon or hemp rope that runs through the swing's arms and frame. Distinctive diamond shapes cut in the back and sides echo a detail from the Adirondack-style *Sunset* chair (published in July 1997). A yellow transparent stain emphasizes the grain of the wood; it is also protected with several coats of an exterior, satin-finish polyurethane. We built the



While away the day in our swing, suspended so its seat tilts comfortably to the rear.

swing of vertical-grain fir, but you could substitute other woods, such as redwood, cedar, or hardwoods suitable for outdoor use.

The average woodworker can build the swing in a weekend; staining and sealing will add several more days,

due to drying time between coats. Most cuts can be made with a circular saw, handsaw, or saber saw, but the angled back support would be more easily cut with a table saw. A full-service lumberyard can generally do this for you.

MATERIALS

- Two 8-foot 2-by-4s
- 32 $2\frac{1}{2}$ -inch deck screws
- Countersinking bit
- Two 10-foot 2-by-4s
- 220 $1\frac{1}{4}$ -inch deck screws
- Nine 10-foot 1-by-4s
- One 10-foot 1-by-6
- $\frac{5}{8}$ - or $\frac{3}{4}$ -inch-diameter rope

COST: About \$150

DIRECTIONS

The 1-by-4 boards used for the swing seat, sides, and back secure to a frame of 2-by-4s that consists of two rectangular ends and three crosspieces. You build the swing in stages: basic frame and fascia; sides and seat; back; and armrests.

FRAME

1. Each frame side is made as follows: Cut two 2-by-4 pieces 17 inches long and two $22\frac{7}{8}$ inches long. Butt the two shorter pieces

A. frame, end view

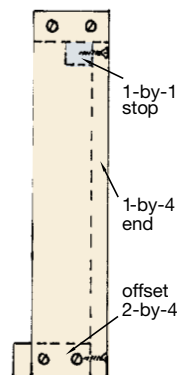

against the ends of one long one, flush with the top of the long one. Secure with two $2\frac{1}{2}$ -inch countersunk deck screws. Position the bottom long piece between the short ones, flush with their bottom edges but offset to the inside by the thickness of a 1-by-4 (see drawing **B**). Secure it with two screws into each end. Repeat to make other frame side.

2. Cut four 2-by-4 crosspieces $52\frac{3}{8}$ inches long. One will be the top support for the back boards. Its front face needs to be cut to an 80° angle. If you have a table saw, raise the blade to its full height and angle it at 10° off vertical. Position the fence so that the top of the blade

angles toward it and space it far enough away from the blade so the cut will just break through the side of the board.

If you have a circular saw, you'll need a cutting guide. Use a protractor to set the fully extended blade at 10° off vertical. Tack the guide to one of the other crosspieces. Align and tack the crosspiece to be cut so the blade will just break through the vertical face of the 2-by-4. Cut the 80° angle the full length of the crosspiece.

3. Place the two frame sides parallel on a work surface with the offset boards on the bottom facing in. Position the front crosspiece so

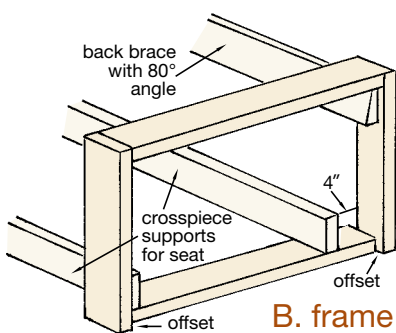

its ends are flush with the outside edges of the offset boards. Secure each end with four 2½-inch deck screws through the crosspiece and into the side.

4. Stand the frame sides on their back edges. Position the crosspiece with the angled cut between the inside top rear corners (see **B**) with the angled face facing front; stop the crosspiece

short of the frame sides' outside edges by the thickness of a 1-by-4. Attach with two 2½-inch countersunk screws near the bottom and one 1¼-inch deck screw through the angled top.

5. Add the third crosspiece so its back edge is 4 inches from the inside back of the side frames. Secure each end with two 2½-inch countersunk screws running through the bottom of the frame and into the crosspiece. The fourth crosspiece will be attached later.

BOARDS AND BACK CUTOUTS

6. Cut the 1-by-4s for the sides, seat, and back. For the sides, cut 12 at 15½ inches long; for the seat, cut 12 at 24 inches long; and for the back, cut 12 at 27 inches long.

7. Lay out the diamond cutouts as facing triangles in four pairs of side boards and all of the back boards. For the sides, draw a line across the boards 5 inches from the top end, then draw another line 1½ inches below. Starting at the edge of the board, use a com-



A continuous length of sturdy rope runs through armrests and frame. Note short, notched back board under armrest.

bination square to connect the lines at a 45° angle, then flip the square over and draw a line connecting back to the edge of the board, creating a triangle. Use the same technique for drawing triangles on the back pieces with the midpoint 12½ inches from the top end. Cut out triangle shapes with a saber saw or handsaw.

FASCIA BOARD

8. Measure a 1-by-6 fascia board to fit between the side frames. It should be 46¾ inches long, but check your distance and cut to size. Draw a line 1 inch from the bottom edge of the board. From the bottom edge, starting 1½ inches from each end, draw a quarter circle up to join this line (see **C**). Cut out with saber saw.

9. With a rasp or sander, round the top front edge of fascia board. Place a seat board on the crosspieces. Position the fascia board so its rear top edge is flush with the top of the seat board. Mark five evenly spaced points on a line 2 inches down from the top of the fascia board. Countersink five 1¼-inch deck screws at these points. Remove seat board.

SIDES

10. Rip a 1-inch-wide strip from remaining 1-by-4. From this strip, cut two pieces to fit between the front pieces of the side frames and the angled face of the back support (match angle; see **D**). The side boards will screw to these stops. Align the stops with ends of

C. front

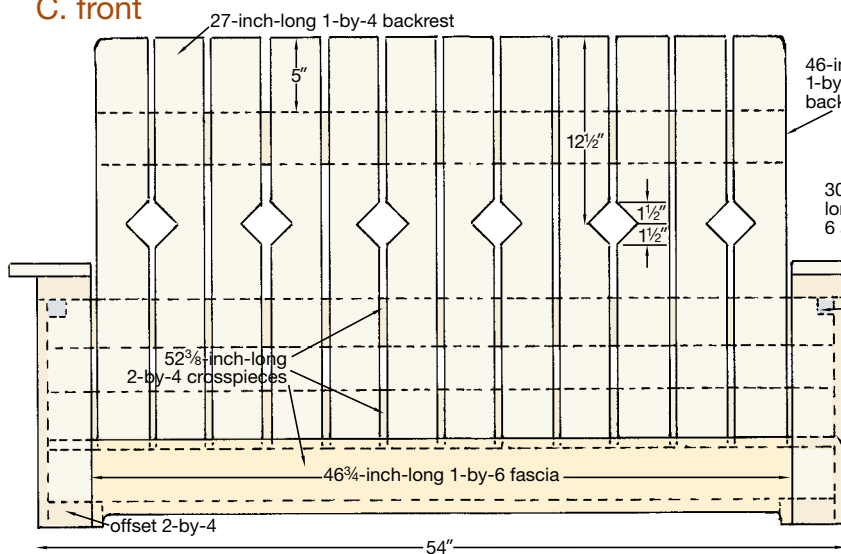

D. side

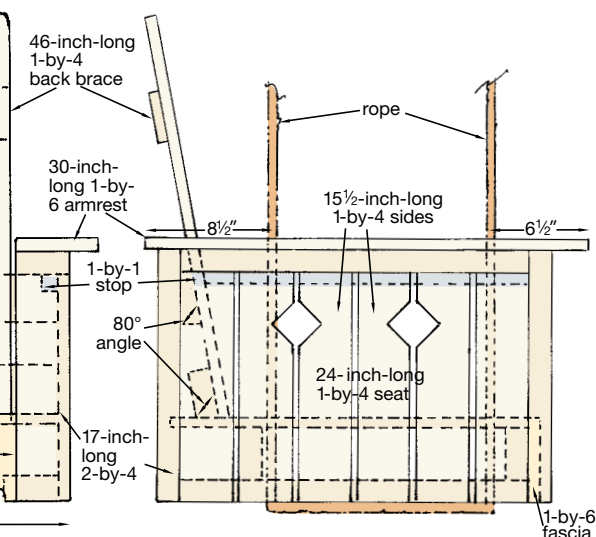



Back brace secures in top rear corner of side frame. A slice cut from its front face helps create the comfortable angle of the back.

crosspieces (see **A**). Attach with countersunk 1 $\frac{1}{4}$ -inch deck screws.

11. Turn frame on one end. Test-fit six side boards as shown in **D**: The outside two boards butt against the frame, and there are $\frac{3}{8}$ -inch spaces between other boards. Countersink 1 $\frac{1}{4}$ -inch deck screws through boards, $\frac{3}{4}$ inch in from each edge, to stop and frame bottom. Repeat for opposite side.

SEAT

12. Position seat boards so they butt against fascia board and are spaced about $\frac{3}{8}$ inch apart. Draw lines across boards to mark centers of crosspieces. Countersink 1 $\frac{1}{4}$ -inch deck screws along these lines, $\frac{3}{4}$ inch in from each edge of each board.

13. Place remaining 2-by-4 crosspiece on seat above the bottom rear crosspiece. Mark position of seat boards on this crosspiece. Measure width of the seat. Cut a piece of 1-by-4 to 1 inch less than this

length; this is the back brace. Butt and center the 1-by-4 against the edge of the 2-by-4 crosspiece and transfer board-spacing marks.

BACK

14. Place the 2-by-4 crosspiece and 1-by-4 back brace parallel and 15 inches apart (use scraps of 1-by-4 to elevate the back brace). Overlay back boards so they are flush and square with bottom of crosspiece and aligned on marks drawn on boards. Draw lines 2 inches and 18 $\frac{1}{2}$ inches from the bottom, then countersink 1 $\frac{1}{4}$ -inch deck screws along these lines $\frac{3}{4}$ inch from each edge of each board.

15. To create a tilt to the rear, set the blade of the table or circular saw at 10° off vertical and trim along the bottom edge of the back assembly, cutting through both the 1-by-4s and the crosspiece.

16. Place back assembly on seat so it pitches to the rear and rests flush against the angled face of the upper crosspiece. Draw a line across front face of all the back boards marking the center of the crosspiece, then countersink 1 $\frac{1}{4}$ -inch deck screws along this line $\frac{3}{4}$ inch from each edge of each back board.

17. Turn swing on the front face of frame and add five 1 $\frac{1}{4}$ -inch deck screws through undersides of seat boards into the crosspiece.

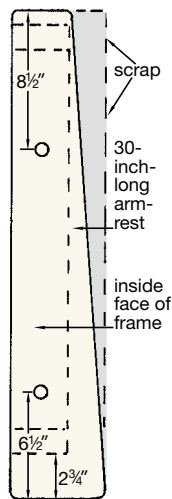

E. armrest

to top of side frame so the front projects 2 $\frac{3}{4}$ inches and the straight side is flush to the top inside edge (see **C** and **D**).

19. Optional: For a more finished appearance, you can insert partial back boards

under the armrests to mask the exposed ends of the crosspieces (see photo, page 138). Remember to trim both ends to an 80° angle; notch the top to fit around the stop. Check fit, then set aside.

ROPE SUPPORTS

20. The holes for the rope supports run just inside the crosspieces and must all align vertically. Draw a line front to back 1 $\frac{3}{4}$ inches from the inside edge of the armrest. Locate points 6 $\frac{1}{2}$ inches from the front and 8 $\frac{1}{2}$ inches from the rear. At those points drill $\frac{3}{4}$ -inch holes through the armrest and frame. Run a length of dowel at least 20 inches long through these holes to the seat, check to be sure dowel is vertical, and mark the seat boards where the dowel hits. Take out both of these seat boards and mark where the dowel meets the frame bottom. Drill holes through the marks in the frame and seat boards. Reattach the seat boards. Finally, attach the insert back boards with notched tops.

FINISHING TOUCHES

Sand all surfaces and edges with medium- and fine-grain sandpaper before staining and/or sealing the swing. We used a water-based Minwax stain called Mustard (800/523-9299 or www.minwax.com) and sealed the surface with a satin-finish water-base polyurethane (Varathane: 800/635-3286 or www.flecto.com).

A knot tied in the end of $\frac{5}{8}$ -inch white nylon rope supports the swing. (You could substitute a hemp rope or heavy-duty chain.)

How you suspend the swing depends on your location. The swing weighs about 100 pounds empty. Add two adults, and there is considerable weight on both the rope and the structure or branch that supports it. Check the load capacity of the rope you select. A continuous length of rope runs from the support through one set of holes, under the frame, and back up (see **D**). Hint: Wrapping rope ends with tape prevents fraying. Lock the rope in place on the bottom with oversize staples that straddle the rope. Adjust it so the front of the swing hangs slightly higher than the rear.

Now all that's needed is a tall glass of iced tea. ♦